

SITE DEVELOPMENT PLANS

BARRINGTON STORAGE-OFFICE

MAP 220 LOTS 54-7-1 & 54-7-2
ROUTE 125
BARRINGTON, NEW HAMPSHIRE

LIST OF PLANS

- | | |
|---|--|
| <p>T-1 - TITLE SHEET</p> <p>T-2 - NEIGHBORHOOD PLAN (1"=200')</p> <p>EX-1 - EXISTING CONDITIONS PLAN (1"=60')</p> <p>SSS-1 - SITE SPECIFIC SOILS PLAN</p> <p>SSS-2 - SITE SPECIFIC TEST PITS</p> <p>BLA-1 - BOUNDARY LINE ADJUSTMENT PLAN (1"=60')</p> <p>NHDES-1 - NHDES SUBDIVISION PLAN (1"=20')</p> <p>SP-1 - GENERAL SITE PLAN (1"=60')</p> <p>SP-2 - SITE DEVELOPMENT PLAN (1"=30')</p> <p>SP-2A - SITE DEVELOPMENT PLAN (1"=30')</p> <p>SP-3 - UTILITY PLAN (1"=30')</p> <p>SP-3A - UTILITY PLAN (1"=30')</p> <p>SP-4 - GRADING AND DRAINAGE PLAN (1"=30')</p> <p>SP-4A - GRADING AND DRAINAGE PLAN (1"=30')</p> <p>SP-5 - CONSTRUCTION DETAILS</p> <p>SP-6 - CONSTRUCTION DETAILS</p> | <p>SP-7 - CONSTRUCTION DETAILS</p> <p>SP-8 - SEWER DETAILS</p> <p>SP-9 - SEWER DETAILS</p> <p>ISDS-1 - INDIVIDUAL SEWAGE DISPOSAL SYSTEM PLAN (LOT 54-7-1)</p> <p>ISDS-2 - INDIVIDUAL SEWAGE DISPOSAL SYSTEM PLAN (LOT 54-7-2)</p> <p>ISDS-2A - LOT 54-7-2 SEWER COLLECTION PLAN & PROFILE (SHEET 1)</p> <p>ISDS-2B - LOT 54-7-2 SEWER COLLECTION PLAN & PROFILE (SHEET 2)</p> <p>C-1 - PLAN AND PROFILE PLAN (STA 0+00 TO STA 5+30)</p> <p>C-2 - PLAN AND PROFILE PLAN (STA 5+30 TO END)</p> <p>C-3 - BIORETENTION PLAN AND DETAILS</p> <p>SPP-1 - SPECIAL PERMIT PLAN</p> <p>CIR-1 - TRAFFIC CIRCULATION PLAN</p> <p>Li-1 - LIGHTING PLAN</p> <p>Li-1A - LIGHTING PLAN</p> <p>LA-1 - LANDSCAPE PLAN</p> <p>LA-1A - LANDSCAPE PLAN</p> <p>LA-2 - LANDSCAPE NOTES & DETAILS</p> |
|---|--|

PREPARED FOR:
MILL FALLS REALTY, LLC.
P.O. BOX 627
OSS�PEE, N.H.

OWNER:
MILLS FALLS REALTY, LLC.
P.O. BOX 627
OSS�PEE, NH

PREPARED BY
TRITECH
ENGINEERING CORPORATION

RECEIVED

JUL 02 2020

LAND USE OFFICE

FOR TOWN APPROVAL PURPOSES:

THE SITE REVIEW REGULATIONS OF THE TOWN OF BARRINGTON ARE A PART OF THIS PLAN, AND APPROVAL OF THIS PLAN IS CONTINGENT UPON COMPLETION OF ALL REQUIREMENTS OF SAID SITE REVIEW REGULATIONS, EXCEPTING ONLY MODIFICATIONS MADE IN WRITING BY THE BOARD AND ATTACHED HERETO.

TRITECH

ENGINEERING CORPORATION

765 CENTRAL AVENUE
DOVER, NEW HAMPSHIRE 03830
TELEPHONE 603 746 8107
FAX 603 746 8880

REVISIONS	DATE	DESCRIPTION
12-2-19		REVISED PER PLANNING COMMENTS
5-28-20		GENERAL REVISIONS
6-30-20		REVISED PER PEER REVIEW

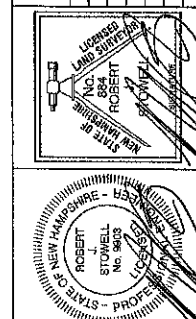

BARRINGTON STORAGE-OFFICE

ROUTE 125
BARRINGTON, NEW HAMPSHIRE

NOVEMBER 11, 2019 JOB No. 19107

TITLE SHEET

T-1

SHEET No.

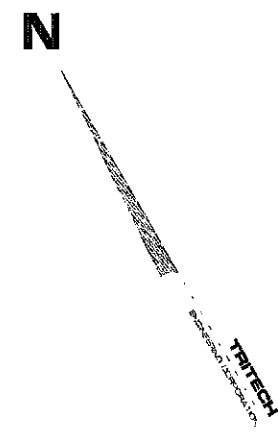
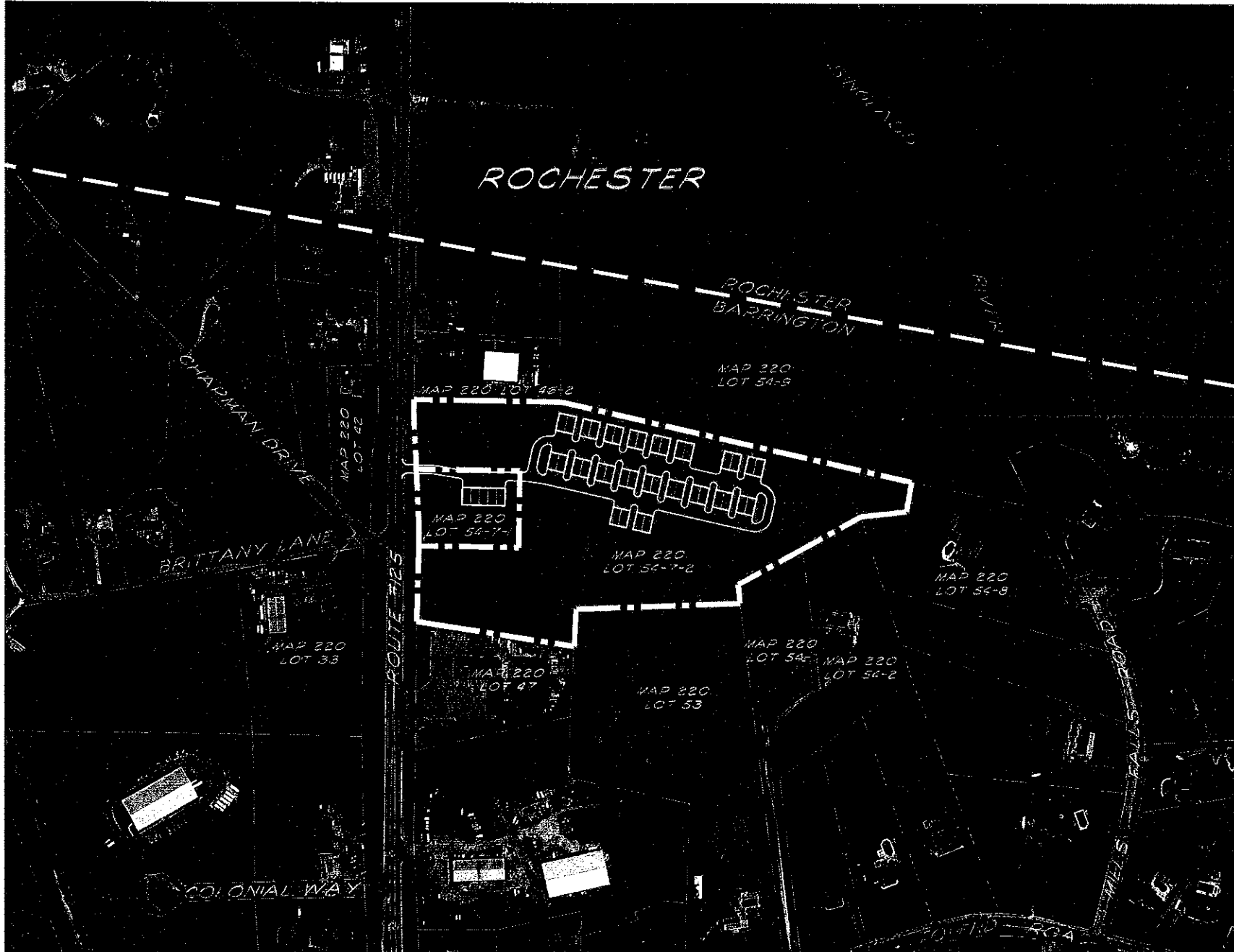

RECEIVED

JUL 02 2020

LAND USE OFFICE

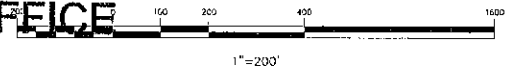

TRITECH
ENGINEERING CORPORATION

785 CENTRAL AVENUE
DOVER NEW HAMPSHIRE 03880
TELEPHONE 603 742 8107
FAX 603 742 8600

REVISIONS	DATE	DESCRIPTION
	5/29/20	GENERAL REVISIONS

NEIGHBORHOOD PLAN
**BARRINGTON
STORAGE-OFFICE**
ROUTE #125
BARRINGTON, NEW HAMPSHIRE
STRAFFORD COUNTY
NOVEMBER 11, 2019 JOB No. 19107
SCALE: 1" = 200'

SHEET No.



NOTES

- 1.) INTENT: TO SHOW THE EXISTING CONDITIONS OF BARRINGTON TAX MAP 220 LOT 54-7-1 & LOT 54-7-2.
- 2.) CURRENT OWNER OF RECORD: MILL FALLS REALTY, LLC
P.O. BOX 627
CENTER OSSIPPEE, N.H.
- 3.) TOTAL LOT AREA: MAP 220 LOT 54-7-1 378,996 SQ.FT. - 8.691 ACRES MAP 220 LOT 54-7-2 286,182 SQ.FT. - 6.570 ACRES
- 4.) TAX MAP 220 LOTS 54-7-1 & 54-7-2
- 5.) PROJECT DEED REFERENCE: BOOK 2821 PAGE 327
- 6.) PROJECT PLAN REFERENCE: BOUNDARY LINE ADJUSTMENT AND SUBDIVISION PLAN
MILL FALLS REALTY, LLC & DOROTHY A. FURVIS
REVOCABLE LIVING TRUST
ROUTE 125 & MILL FALLS ROAD
BARRINGTON, NEW HAMPSHIRE
TRITECH ENGINEERING CORPORATION
MAY 19, 2004 SCRD 77-22
- 7.) BASIS OF BEARING: BEARING SYSTEM BASED ON GPS FIELD OBSERVATIONS ON MARCH 28, 2019 USING TOPCON HIPER SR RECEIVERS AND OPUS CORRECTED ON APRIL 1, 2019. DATUM BASED ON NEW HAMPSHIRE STATE PLANE COORDINATES SPC (2000 NH), (VERTICAL DATUM: NAVD 88).
- 8.) ZONING: REGIONAL COMMERCIAL - RC GENERAL RESIDENTIAL - GR
MIN. LOT SIZE: 40,000 SQ.FT. MIN. LOT SIZE: 80,000 SQ.FT.
MIN. FRONTAGE: 200 FT. MIN. FRONTAGE: 200 FT.
MIN. SETBACKS: MIN. SETBACKS:
FRONT: 75 FT FRONT: 40 FT
SIDE: 30 FT SIDE: 30 FT
REAR: 30 FT REAR: 30 FT
- 9.) THE RAW UNADJUSTED CLOSURE OF OUR RANDOM POINT TRAVERSE WAS 1 PART IN 22,000, AND WAS ACCOMPLISHED USING A SOKKIA SET3100 TOTAL STATION, DURING THE MONTH OF MAY, 2002.
- 10.) DURING 2019, HIGHLAND SOILS (MICHAEL MARIANO, STATE OF NEW HAMPSHIRE CERTIFIED SOIL SCIENTIST #76) CONDUCTED AN ON-SITE WETLANDS DELINEATION OF THE SUBJECT PARCEL. WETLANDS WERE IDENTIFIED BASED ON THE TOWN OF BARRINGTON ZONING ORDINANCE (ARTICLE 9) AND ON STATE & FEDERAL CRITERIA OUTLINED IN THE "CORPS OF ENGINEERS WETLANDS DELINEATION MANUAL" (DEPT. OF THE ARMY, 1987). ON THIS SITE, WETLANDS BASED ON LOCAL CRITERIA SHARE THE SAME BOUNDARIES WITH THOSE BASED ON STATE AND FEDERAL CRITERIA.
- 11.) THE SUBJECT PARCEL IS NOT LOCATED WITHIN A FEDERALLY DESIGNATED SPECIAL FLOOD HAZARD ZONE (FLOOD HAZARD ZONE A - PANEL 0305E, MAP No. 33017C0305E, DATE: 9-30-2015).
- 12.) SEE SHORELAND PROTECTION DISTRICT OVERLAY (SDD), (BARRINGTON ZONING ORDINANCE ARTICLE 11)
- 13.) NHDES WETLANDS AND NON-SITE SPECIFIC PERMIT 2004-01983, EXPIRATION DATE: 09/28/2009.
- 14.) NHDES SUBDIVISION APPROVAL NO.: 2004005422 (TAX MAP 12 LOT 132), DATED 09/20/2004 & NHDES SUBDIVISION APPROVAL NO.: 2004005423 (TAX MAP 12 LOT 970-15), DATED 09/20/2004.
- 15.) NHDOT DRIVEWAY PERMIT NO: 06-027-426, DATED SEPTEMBER 22, 2004.

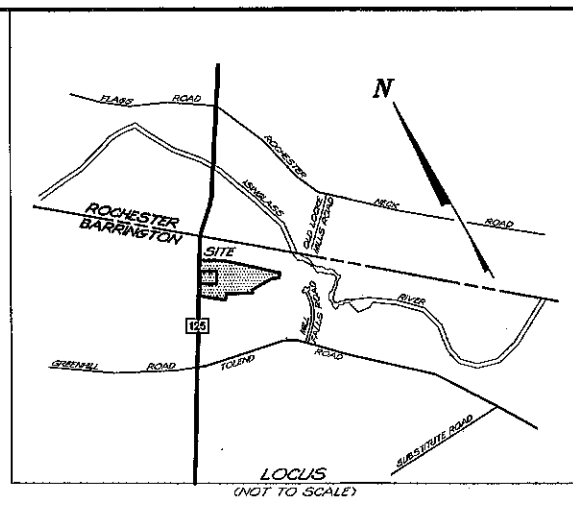
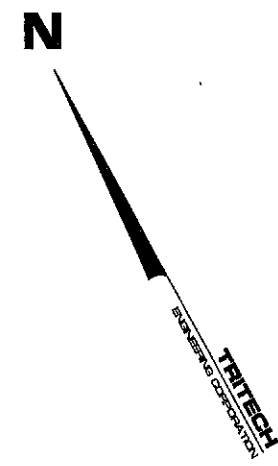

TRITECH
ENGINEERING CORPORATION

725 CENTRAL AVENUE
DOVER, NEW HAMPSHIRE 03806
TELEPHONE 603 746 8007
FAX 603 742 5820

REVISIONS	DATE	DESCRIPTION
12-2-19		REVISED PER PLANNING COMMENTS
5-29-20		GENERAL REVISIONS

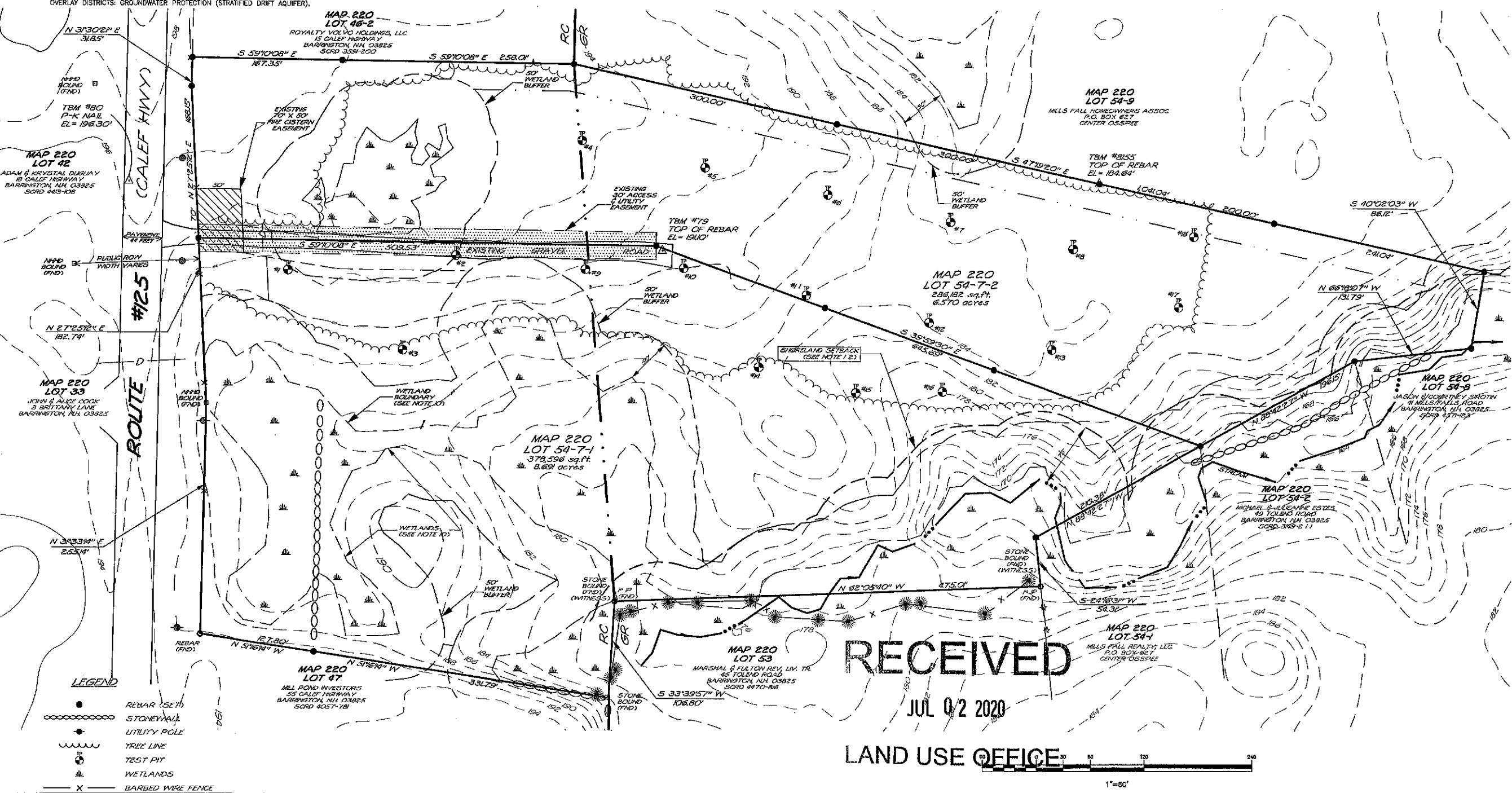
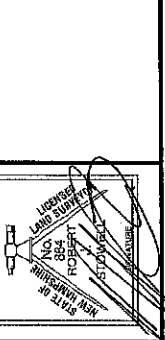

EXISTING CONDITIONS PLAN
MILL FALLS REALTY, LLC.
ROUTE #125
BARRINGTON, NEW HAMPSHIRE
NOVEMBER 11, 2019 JOB No. 19107
SCALE: 1" = 80'

SHEET No. **EX-1**

LEGEND

	REBAR (SET)
	STONEWALL
	UTILITY POLE
	TREE LINE
	TEST PIT
	WETLANDS
	BARBED WIRE FENCE



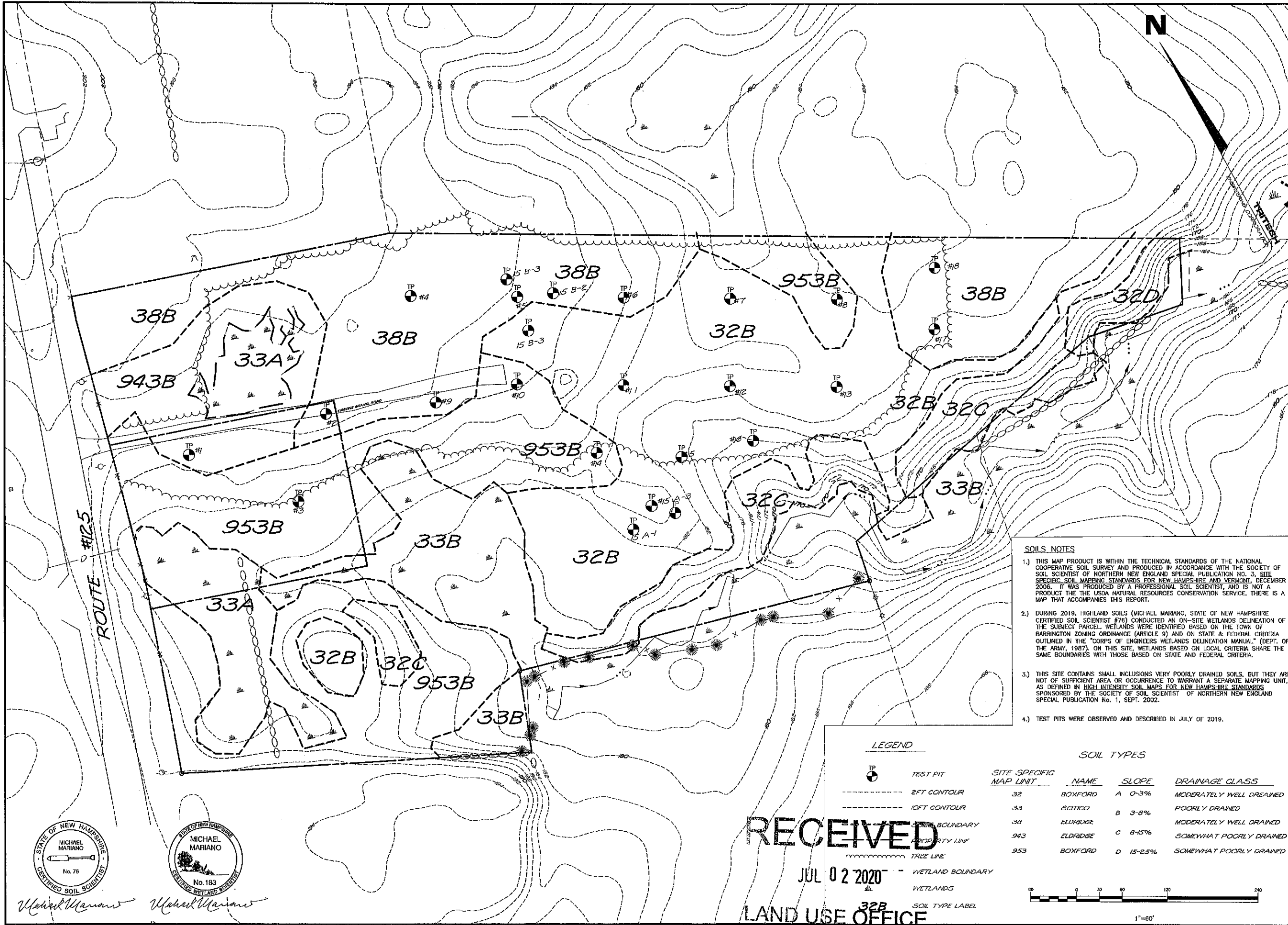

SOILS NOTES

- 1.) THIS MAP PRODUCT IS WITHIN THE TECHNICAL STANDARDS OF THE NATIONAL COOPERATIVE SOIL SURVEY AND PRODUCED IN ACCORDANCE WITH THE SOCIETY OF SOIL SCIENTIST OF NORTHERN NEW ENGLAND SPECIAL PUBLICATION NO. 3, SITE SPECIFIC SOIL MAPPING STANDARDS FOR NEW HAMPSHIRE AND VERMONT, DECEMBER 2008. IT WAS PRODUCED BY A PROFESSIONAL SOIL SCIENTIST, AND IS NOT A PRODUCT OF THE USDA NATURAL RESOURCES CONSERVATION SERVICE. THERE IS A MAP THAT ACCOMPANIES THIS REPORT.
- 2.) DURING 2019, HIGHLAND SOILS (MICHAEL MARIANO, STATE OF NEW HAMPSHIRE CERTIFIED SOIL SCIENTIST #76) CONDUCTED AN ON-SITE WETLANDS DELINEATION OF THE SUBJECT PARCEL. WETLANDS WERE IDENTIFIED BASED ON THE TOWN OF BARRINGTON ZONING ORDINANCE (ARTICLE 9) AND ON STATE & FEDERAL CRITERIA OUTLINED IN THE "CORPS OF ENGINEERS WETLANDS DELINEATION MANUAL" (DEPT. OF THE ARMY, 1987). ON THIS SITE, WETLANDS BASED ON LOCAL CRITERIA SHARE THE SAME BOUNDARIES WITH THOSE BASED ON STATE AND FEDERAL CRITERIA.
- 3.) THIS SITE CONTAINS SMALL INCLUSIONS VERY POORLY DRAINED SOILS, BUT THEY ARE NOT OF SUFFICIENT AREA OR OCCURRENCE TO WARRANT A SEPARATE MAPPING UNIT, AS DEFINED IN HIGH INTENSITY SOIL MAPS FOR NEW HAMPSHIRE STANDARDS SPONSORED BY THE SOCIETY OF SOIL SCIENTIST OF NORTHERN NEW ENGLAND SPECIAL PUBLICATION No. 1, SEPT. 2002.
- 4.) TEST PITS WERE OBSERVED AND DESCRIBED IN JULY OF 2019.

LEGEND

- TP TEST PIT
- 2FT CONTOUR
- 10FT CONTOUR
- PROPERTY BOUNDARY
- PROPERTY LINE
- TREE LINE
- WETLAND BOUNDARY
- WETLANDS
- SOIL TYPE LABEL

SOIL TYPES

SITE SPECIFIC MAP UNIT	NAME	SLOPE	DRAINAGE CLASS
32	BOXFORD	A 0-3%	MODERATELY WELL DRAINED
33	SCITCO	B 3-8%	POORLY DRAINED
38	ELDRIDGE	C 8-15%	MODERATELY WELL DRAINED
943	ELDRIDGE	C 8-15%	SOMEWHAT POORLY DRAINED
953	BOXFORD	D 15-25%	SOMEWHAT POORLY DRAINED

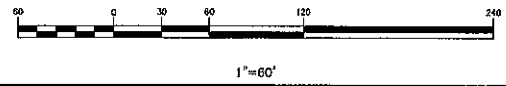

TRITECH

ENGINEERING CORPORATION

765 CENTRAL AVENUE
DOVER, NEW HAMPSHIRE 03820
TELEPHONE 603 748 8707
FAX 603 748 3890

REVISIONS	DATE	DESCRIPTION:
	5/29/20	GENERAL REVISIONS

SITE SPECIFIC SOILS PLAN

BARRINGTON STORAGE OFFICE

ROUTE #125
BARRINGTON, NEW HAMPSHIRE

NOVEMBER 11, 2019 JOB NO. 19107
SCALE: 1" = 100'

SHEET NO.

555-1



Michael Mariano Michael Mariano

RECEIVED
JUL 02 2020
LAND USE OFFICE

TEST PIT 1
 00 - 07" DARK BROWN (10YR4/3) FINE SANDY LOAM; WEAK FINE GRANULAR STRUCTURE; MOIST, FRIABLE.
 07 - 14" DARK YELLOWISH BROWN (10YR4/3) SANDY LOAM; MODERATE MEDIUM GRANULAR STRUCTURE; MOIST, FRIABLE.
 14 - 30" OLIVE GRAY (2.5Y5/2) SILT LOAM; MANY REDOX DEPLETIONS AND CONCENTRATIONS; MODERATE MEDIUM BLOCKY STRUCTURE; MOIST, FIRM.
 30 - 54" OLIVE GRAY (5Y5/3) SILTY CLAY LOAM; MANY REDOX DEPLETIONS AND CONCENTRATIONS; STRONG MEDIUM BLOCKY STRUCTURE; MOIST, VERY FIRM.

SERIES: ELDRIDGE
 ESTIMATED SEASONAL HIGH WATER TABLE: 14"
 OBSERVED WATER: 50"
 RESTRICTIVE LAYER: 30"
 SOIL HYDROLOGIC GROUP: C

TEST PIT 2
 00 - 04" DARK BROWN (10YR3/4) FINE SANDY LOAM; WEAK FINE GRANULAR STRUCTURE; MOIST, FRIABLE.
 04 - 18" YELLOWISH BROWN (10YR5/6) FINE SANDY LOAM; MODERATE MEDIUM GRANULAR STRUCTURE; MOIST, FRIABLE.
 18 - 34" YELLOWISH BROWN (10YR5/6) SANDY LOAM; COMMON REDOX CONCENTRATIONS IN 7.5YR5/8 AND 2.5YR4/2, AND FEW DEPLETIONS IN 10YR6/1; MODERATE MEDIUM GRANULAR STRUCTURE; MOIST, FRIABLE.
 34 - 49" YELLOWISH BROWN (10YR5/6) LOAMY FINE SAND WITH REDOX FEATURES AS IN ABOVE HORIZON; MASSIVE STRUCTURE; MOIST, FRIABLE.
 49 - 60" OLIVE GRAY (2.5Y5/2) SILTY CLAY LOAM; MANY REDOX DEPLETIONS AND CONCENTRATIONS; STRONG MEDIUM BLOCKY STRUCTURE; MOIST, VERY FIRM.

SERIES: ELDRIDGE
 ESTIMATED SEASONAL HIGH WATER TABLE: 18"
 OBSERVED WATER: NONE
 RESTRICTIVE LAYER: 48"
 SOIL HYDROLOGIC GROUP: C

TEST PIT 3
 00 - 08" DARK BROWN (10YR4/3) FINE SANDY LOAM; WEAK FINE GRANULAR STRUCTURE; MOIST, FRIABLE.
 08 - 13" LIGHT OLIVE BROWN (2.5Y5/4) SILT LOAM; MODERATE MEDIUM GRANULAR STRUCTURE; MOIST, FRIABLE.
 13 - 29" LIGHT OLIVE BROWN (2.5Y5/4) SILT LOAM; COMMON REDOX FEATURES IN 10YR6/1 AND 7.5YR5/8; MODERATE MEDIUM BLOCKY STRUCTURE; MOIST, FIRM.
 29 - 54" OLIVE GRAY (5Y5/2) SILTY CLAY LOAM; MANY REDOX DEPLETIONS AND CONCENTRATIONS; STRONG MEDIUM BLOCKY STRUCTURE; MOIST, VERY FIRM.

SERIES: BOXFORD
 ESTIMATED SEASONAL HIGH WATER TABLE: 13"
 OBSERVED WATER: NONE
 RESTRICTIVE LAYER: 23"
 SOIL HYDROLOGIC GROUP: C

TEST PIT 4
 00 - 04" DARK BROWN (10YR3/4) FINE SANDY LOAM; WEAK FINE GRANULAR STRUCTURE; MOIST, FRIABLE.
 04 - 10" STRONG BROWN (7.5YR5/8) SANDY LOAM; MODERATE MEDIUM GRANULAR STRUCTURE; MOIST, FRIABLE.
 10 - 20" BROWN (10YR4/4) SANDY LOAM; MODERATE MEDIUM GRANULAR STRUCTURE; MOIST, FRIABLE.
 20 - 27" LIGHT OLIVE BROWN (2.5Y5/4) SANDY LOAM; MANY REDOX DEPLETIONS IN 10YR6/1 AND 7.5YR5/8; MODERATE MEDIUM GRANULAR STRUCTURE; MOIST, FRIABLE.
 27-54" OLIVE GRAY (5Y5/2) SILTY CLAY LOAM; MANY REDOX DEPLETIONS AND CONCENTRATIONS; STRONG MEDIUM BLOCKY STRUCTURE; MOIST, VERY FIRM.

SERIES: ELDRIDGE
 ESTIMATED SEASONAL HIGH WATER TABLE: 20"
 OBSERVED WATER: NONE
 RESTRICTIVE LAYER: 27"
 SOIL HYDROLOGIC GROUP: C

TEST PIT 5
 00 - 05" DARK BROWN (10YR3/4) FINE SANDY LOAM; WEAK FINE GRANULAR STRUCTURE; MOIST, FRIABLE.
 05 - 20" STRONG BROWN (7.5YR5/8) SANDY LOAM; MODERATE MEDIUM GRANULAR STRUCTURE; MOIST, FRIABLE.
 20 - 24" LIGHT OLIVE BROWN (2.5Y5/4) SILT LOAM; FEW REDOX FEATURES IN 10YR6/1 AND 7.5YR5/8; MODERATE MEDIUM GRANULAR STRUCTURE; MOIST, FRIABLE.
 24 - 48" OLIVE GRAY (5Y5/2) SILTY CLAY LOAM; MANY REDOX DEPLETIONS AND CONCENTRATIONS; STRONG MEDIUM BLOCKY STRUCTURE; MOIST, VERY FIRM.

SERIES: ELDRIDGE
 ESTIMATED SEASONAL HIGH WATER TABLE: 20"
 OBSERVED WATER: NONE
 RESTRICTIVE LAYER: 27"
 SOIL HYDROLOGIC GROUP: C

TEST PIT 6
 00 - 04" DARK BROWN (10YR3/4) FINE SANDY LOAM; WEAK FINE GRANULAR STRUCTURE; MOIST, FRIABLE.
 04 - 10" STRONG BROWN (7.5YR5/8) SANDY LOAM; MODERATE MEDIUM GRANULAR STRUCTURE; MOIST, FRIABLE.
 10 - 20" LIGHT OLIVE BROWN (2.5Y5/4) SILT LOAM; FEW REDOX FEATURES IN 10YR6/1 AND 7.5YR5/8; MODERATE MEDIUM GRANULAR STRUCTURE; MOIST, FRIABLE.
 20 - 27" LIGHT OLIVE BROWN (2.5Y5/4) SANDY LOAM; MANY REDOX DEPLETIONS AND CONCENTRATIONS; MODERATE MEDIUM GRANULAR STRUCTURE; MOIST, FRIABLE.
 27 - 48" OLIVE GRAY (5Y5/2) SILTY CLAY LOAM; MANY REDOX DEPLETIONS AND CONCENTRATIONS; STRONG MEDIUM BLOCKY STRUCTURE; MOIST, VERY FIRM.

SERIES: ELDRIDGE
 ESTIMATED SEASONAL HIGH WATER TABLE: 20"
 OBSERVED WATER: NONE
 RESTRICTIVE LAYER: 27"
 SOIL HYDROLOGIC GROUP: C

TEST PIT 7
 00 - 05" DARK BROWN (10YR4/3) SILT LOAM; WEAK FINE GRANULAR STRUCTURE; MOIST, FRIABLE.
 05 - 10" YELLOWISH BROWN (10YR5/6) SILT LOAM; MODERATE MEDIUM GRANULAR STRUCTURE; MOIST, FRIABLE.
 19 - 26" LIGHT OLIVE BROWN (2.5Y5/4) SILT LOAM; MANY REDOX FEATURES IN 10YR6/1 AND 7.5YR5/8; MODERATE MEDIUM GRANULAR STRUCTURE; MOIST, FRIABLE.
 26 - 48" OLIVE GRAY (5Y5/2) SILTY CLAY LOAM; MANY REDOX DEPLETIONS AND CONCENTRATIONS; MOIST, VERY FIRM.

SERIES: BOXFORD
 ESTIMATED SEASONAL HIGH WATER TABLE: 19"
 OBSERVED WATER: NONE
 RESTRICTIVE LAYER: 26"
 SOIL HYDROLOGIC GROUP: C

TEST PIT 8
 00 - 03" DARK BROWN (10YR4/3) SILT LOAM; WEAK FINE GRANULAR STRUCTURE; MOIST, FRIABLE.
 03 - 10" LIGHT OLIVE BROWN (2.5Y5/4) SILT LOAM; MASSIVE STRUCTURE; MOIST, FRIABLE.
 10 - 19" LIGHT OLIVE BROWN (2.5Y5/4) SILT LOAM; FEW REDOX FEATURES IN 10YR6/1 AND 7.5YR5/8; MODERATE MEDIUM BLOCKY STRUCTURE; MOIST, FIRM.
 19 - 36" OLIVE GRAY (5Y5/3) SILTY CLAY LOAM; MANY REDOX DEPLETIONS AND CONCENTRATIONS; STRONG MEDIUM BLOCKY STRUCTURE; MOIST, VERY FIRM.

SERIES: BOXFORD
 ESTIMATED SEASONAL HIGH WATER TABLE: 13"
 OBSERVED WATER: NONE
 RESTRICTIVE LAYER: 29"
 SOIL HYDROLOGIC GROUP: C

TEST PIT 9
 00 - 05" DARK BROWN (10YR4/3) FINE SANDY LOAM; WEAK FINE GRANULAR STRUCTURE; MOIST, FRIABLE.
 05 - 16" STRONG BROWN (7.5YR5/8) SANDY LOAM; MODERATE MEDIUM GRANULAR STRUCTURE; MOIST, FRIABLE.
 16 - 25" BROWN (10YR4/4) SANDY LOAM; WEAK MEDIUM GRANULAR STRUCTURE; MOIST, FRIABLE.
 25 - 30" LIGHT OLIVE BROWN (2.5Y5/4) SANDY LOAM; FEW REDOX DEPLETIONS AND CONCENTRATIONS; MODERATE MEDIUM GRANULAR STRUCTURE; MOIST, FRIABLE.
 30 - 48" OLIVE GRAY (5Y5/2) SILTY CLAY LOAM; MANY REDOX DEPLETIONS AND CONCENTRATIONS; STRONG MEDIUM BLOCKY STRUCTURE; MOIST, VERY FIRM.

SERIES: ELDRIDGE
 ESTIMATED SEASONAL HIGH WATER TABLE: 25"
 OBSERVED WATER: NONE
 RESTRICTIVE LAYER: 30"
 SOIL HYDROLOGIC GROUP: C

TEST PIT 10
 00 - 04" DARK BROWN (10YR3/4) FINE SANDY LOAM; WEAK FINE GRANULAR STRUCTURE; MOIST, FRIABLE.
 04 - 14" LIGHT OLIVE BROWN (2.5Y5/4) SILT LOAM; MODERATE MEDIUM GRANULAR STRUCTURE; MOIST, FRIABLE.
 14 - 19" LIGHT OLIVE BROWN (2.5Y5/4) SILT LOAM; FEW REDOX FEATURES IN 10YR6/1 AND 7.5YR5/8; MODERATE MEDIUM GRANULAR STRUCTURE; MOIST, FRIABLE.
 19 - 48" OLIVE GRAY (5Y5/2) SILTY CLAY LOAM; MANY REDOX DEPLETIONS AND CONCENTRATIONS; STRONG MEDIUM BLOCKY STRUCTURE; MOIST, VERY FIRM.

SERIES: BOXFORD
 ESTIMATED SEASONAL HIGH WATER TABLE: 14"
 OBSERVED WATER: NONE
 RESTRICTIVE LAYER: 19"
 SOIL HYDROLOGIC GROUP: C

TEST PIT 11
 00 - 05" DARK BROWN (10YR3/4) VERY FINE SANDY LOAM; WEAK FINE GRANULAR STRUCTURE; MOIST, FRIABLE.
 05 - 18" LIGHT OLIVE BROWN (2.5Y5/4) SILT LOAM; MASSIVE STRUCTURE; MOIST, FRIABLE.
 18 - 27" LIGHT OLIVE BROWN (2.5Y5/4) SAND; FEW REDOX DEPLETIONS IN 10YR6/1; MASSIVE STRUCTURE; MOIST, FRIABLE.
 27 - 48" OLIVE GRAY (5Y5/2) SILTY CLAY LOAM; MANY REDOX DEPLETIONS AND CONCENTRATIONS; STRONG MEDIUM BLOCKY STRUCTURE; MOIST, VERY FIRM.

SERIES: BOXFORD
 ESTIMATED SEASONAL HIGH WATER TABLE: 18"
 OBSERVED WATER: NONE
 RESTRICTIVE LAYER: 24"
 SOIL HYDROLOGIC GROUP: C

TEST PIT 12
 00 - 04" DARK BROWN (10YR3/4) VERY FINE SANDY LOAM; WEAK FINE GRANULAR STRUCTURE; MOIST, FRIABLE.
 04 - 18" YELLOWISH BROWN (10YR5/6) SILT LOAM; MASSIVE STRUCTURE; MOIST, FRIABLE.
 18 - 24" YELLOWISH BROWN (10YR5/6) SILT LOAM; FEW REDOX FEATURES IN 10YR6/1; MASSIVE STRUCTURE; MOIST, FRIABLE.
 24 - 60" OLIVE GRAY (5Y5/2) SILTY CLAY LOAM; MANY REDOX DEPLETIONS AND CONCENTRATIONS; STRONG MEDIUM BLOCKY STRUCTURE; MOIST, VERY FIRM.

SERIES: BOXFORD
 ESTIMATED SEASONAL HIGH WATER TABLE: 15"
 OBSERVED WATER: NONE
 RESTRICTIVE LAYER: 24"
 SOIL HYDROLOGIC GROUP: C

TEST PIT 13
 00 - 05" DARK BROWN (10YR3/4) FINE SANDY LOAM; WEAK FINE GRANULAR STRUCTURE; MOIST, FRIABLE.
 05 - 10" STRONG BROWN (7.5YR5/8) FINE SANDY LOAM; WEAK FINE GRANULAR STRUCTURE; MOIST, FRIABLE.
 10 - 21" YELLOWISH BROWN (10YR5/6) FINE SANDY LOAM; MODERATE MEDIUM GRANULAR STRUCTURE; MOIST, FRIABLE.
 21 - 38" LIGHT OLIVE BROWN (2.5Y5/4) SILT LOAM; FEW REDOX FEATURES IN 10YR6/1 AND 7.5YR5/8; MASSIVE STRUCTURE; MOIST, FRIABLE.
 38 - 60" OLIVE GRAY (5Y5/2) SILTY CLAY LOAM; MANY REDOX DEPLETIONS AND CONCENTRATIONS; STRONG MEDIUM BLOCKY STRUCTURE; MOIST, VERY FIRM.

SERIES: BOXFORD
 ESTIMATED SEASONAL HIGH WATER TABLE: 21"
 OBSERVED WATER: NONE
 RESTRICTIVE LAYER: 30"
 SOIL HYDROLOGIC GROUP: C

TEST PIT 14
 00 - 03" DARK BROWN (10YR3/4) VERY FINE SANDY LOAM; WEAK FINE GRANULAR STRUCTURE; MOIST, FRIABLE.
 03 - 14" LIGHT OLIVE BROWN (2.5Y5/4) SILT LOAM; MASSIVE STRUCTURE; MOIST, FRIABLE.
 14 - 19" LIGHT OLIVE BROWN (2.5Y5/4) SILT LOAM; FEW REDOX FEATURES IN 10YR6/1; MASSIVE STRUCTURE; MOIST, FRIABLE.
 19 - 60" OLIVE GRAY (5Y5/2) SILTY CLAY LOAM; MANY REDOX DEPLETIONS AND CONCENTRATIONS; STRONG MEDIUM BLOCKY STRUCTURE; MOIST, VERY FIRM.

SERIES: BOXFORD
 ESTIMATED SEASONAL HIGH WATER TABLE: 14"
 OBSERVED WATER: NONE
 RESTRICTIVE LAYER: 19"
 SOIL HYDROLOGIC GROUP: C

TEST PIT 15
 00 - 05" DARK BROWN (10YR3/4) SILT LOAM; WEAK FINE GRANULAR STRUCTURE; MOIST, FRIABLE.
 05 - 18" LIGHT OLIVE BROWN (2.5Y5/4) SILT LOAM; MASSIVE STRUCTURE; MOIST, FRIABLE.
 18 - 23" LIGHT OLIVE BROWN (2.5Y5/4) SILT LOAM; FEW REDOX FEATURES IN 10YR6/1; MASSIVE STRUCTURE; MOIST, FRIABLE.
 23 - 60" OLIVE GRAY (5Y5/3) SILTY CLAY LOAM; MANY REDOX DEPLETIONS AND CONCENTRATIONS; STRONG MEDIUM BLOCKY STRUCTURE; MOIST, VERY FIRM.

SERIES: BOXFORD
 ESTIMATED SEASONAL HIGH WATER TABLE: 18"
 OBSERVED WATER: NONE
 RESTRICTIVE LAYER: 24"
 SOIL HYDROLOGIC GROUP: C

TEST PIT 17
 00 - 06" DARK BROWN (10YR4/3) FINE SANDY LOAM; WEAK FINE GRANULAR STRUCTURE; MOIST, FRIABLE.
 06 - 24" YELLOWISH BROWN (10YR5/6) FINE SANDY LOAM; WEAK MEDIUM GRANULAR STRUCTURE; MOIST, FRIABLE.
 24 - 28" BROWN (10YR4/5) FINE SANDY LOAM; WEAK MEDIUM GRANULAR STRUCTURE; MOIST, FRIABLE.
 28 - 34" LIGHT OLIVE BROWN (2.5Y5/4) SILT LOAM; FEW REDOX DEPLETIONS AND CONCENTRATIONS; MODERATE MEDIUM GRANULAR STRUCTURE; MOIST, FRIABLE.
 34 - 60" OLIVE GRAY (2.5Y5/2) SILTY CLAY LOAM; MANY REDOX DEPLETIONS AND CONCENTRATIONS; STRONG MEDIUM BLOCKY STRUCTURE; MOIST, VERY FIRM.

SERIES: ELDRIDGE
 ESTIMATED SEASONAL HIGH WATER TABLE: 26"
 OBSERVED WATER: NONE
 RESTRICTIVE LAYER: 34"
 SOIL HYDROLOGIC GROUP: C

TEST PIT 18
 00 - 08" DARK BROWN (10YR4/3) FINE SANDY LOAM; WEAK FINE GRANULAR STRUCTURE; MOIST, FRIABLE.
 08 - 11" YELLOWISH BROWN (10YR5/6) FINE SANDY LOAM; MODERATE MEDIUM GRANULAR STRUCTURE; MOIST, FRIABLE.
 11 - 24" LIGHT OLIVE BROWN (2.5Y5/4) FINE SANDY LOAM; MODERATE MEDIUM GRANULAR STRUCTURE; MOIST, FRIABLE.
 24 - 45" YELLOWISH BROWN (10YR5/6) SANDY LOAM; WEAK MEDIUM GRANULAR STRUCTURE; MOIST, FRIABLE.
 45 - 52" YELLOWISH BROWN (10YR5/6) LOAMY FINE SAND; FEW REDOX DEPLETIONS IN 10YR6/1; MASSIVE STRUCTURE; MOIST, FRIABLE.
 52 - 60" OLIVE GRAY (2.5Y5/2) & YELLOWISH BROWN (10YR5/6) SILTY CLAY LOAM; MANY REDOX DEPLETIONS AND CONCENTRATIONS; STRONG MEDIUM BLOCKY STRUCTURE; MOIST, VERY FIRM.

SERIES: ELDRIDGE, WELL DRAINER, DEEP PHASE
 ESTIMATED SEASONAL HIGH WATER TABLE: 45"
 OBSERVED WATER: NONE
 RESTRICTIVE LAYER: 52"
 SOIL HYDROLOGIC GROUP: C

TEST PIT 19
 NORTH SIDE OF GARAGE. ORIGINAL 'A' HORIZON REMOVED.
 00 - 19" YELLOWISH BROWN (10YR5/6) GRAVELLY SAND FILL; SINGLE GRAIN; DRY, LOOSE.
 19 - 25" LIGHT GRAY (10.5YR5/5) SAND; FEW BLACK CONCRETIONS; SINGLE GRAIN; MOIST, LOOSE.
 29 - 40" YELLOWISH BROWN (10YR5/6) & STRONG BROWN (7.5YR5/8) SAND; MANY REDOX DEPLETIONS IN 10YR6/1; SINGLE GRAIN; MOIST, LOOSE.

SERIES: FILL OVER SANDY TILL
 ESTIMATED SEASONAL HIGH WATER TABLE: 19"
 OBSERVED WATER: NONE
 RESTRICTIVE LAYER: NONE TO 40"
 SOIL HYDROLOGIC GROUP: C

TRITECH
 ENGINEERING CORPORATION

7855 CENTRAL AVENUE
 DOVER, NEW HAMPSHIRE 03804
 TELEPHONE 603 742 8107
 FAX 603 742 8820

REVISIONS	DATE	DESCRIPTION

SITE SPECIFIC SOILS, TEST PITS
BARRINGTON STORAGE OFFICE
 ROUTE #125
 BARRINGTON, NEW HAMPSHIRE
 NOVEMBER 11, 2019
 JOB No. 19107

SHEET No. **000-2**

RECEIVED
 JUL 02 2020
 LAND USE OFFICE

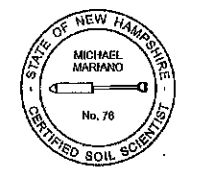

Michael Marano

NOTES

- INTENT TO ADJUST THE PROPERTY BOUNDARY LINES BETWEEN BARRINGTON TAX MAP 220 LOT 54-7-1 & LOT 54-7-2, BY TRANSFERRING PARCEL "A" (313,948 SQ.FT.) FROM LOT 54-7-1 TO LOT 54-7-2.
- CURRENT OWNER OF RECORD: MILL FALLS REALTY, LLC
P.O. BOX 627
CENTER OSSISPEE, N.H.
- TOTAL LOT AREA:

MAP 220 LOT 54-7-1	MAP 220 LOT 54-7-2
378,596 SQ.FT. - 8.691 ACRES	288,182 SQ.FT. - 6.570 ACRES
ORIGINAL PARCEL "A" - 313,948 SQ.FT. - 7.207 ACRES	+ 313,948 SQ.FT. - 7.207 ACRES
FINAL	600,130 SQ.FT. - 13.777 ACRES
- TAX MAP 220 LOTS 54-7-1 & 54-7-2
- PROJECT DEED REFERENCE: BOOK 2821 PAGE 327
- PROJECT PLAN REFERENCE: BOUNDARY LINE ADJUSTMENT AND SUBDIVISION PLAN
MILL FALLS REALTY, LLC &
DOROTHY A. FURVIS
REVOCABLE LIVING TRUST
ROUTE 125 & MILL FALLS ROAD
BARRINGTON, NEW HAMPSHIRE
TRITECH ENGINEERING CORPORATION
MAY 19, 2004 SCRD 77-22
- BASIS OF BEARING: BEARING SYSTEM BASED ON GPS FIELD OBSERVATIONS ON MARCH 28, 2019 USING TOPCON HIPER SR RECEIVERS AND OPUS CORRECTED ON APRIL 1, 2019. DATUM BASED ON NEW HAMPSHIRE STATE PLANE COORDINATES SPC (2800 NH), (VERTICAL DATUM: NAVD 88).

- ZONING: REGIONAL COMMERCIAL - RC GENERAL RESIDENTIAL - GR
MIN. LOT SIZE: 40,000 SQ.FT. MIN. LOT SIZE: 80,000 SQ.FT.
MIN. FRONTAGE: 200 FT. MIN. FRONTAGE: 200 FT.
MIN. SETBACKS: MIN. SETBACKS:
FRONT: 75 FT FRONT: 40 FT
SIDE: 30 FT SIDE: 30 FT
REAR: 30 FT REAR: 30 FT
OVERLAY DISTRICTS: GROUNDWATER PROTECTION (STRATIFIED DRIFT AQUIFER),
- THE RAW UNADJUSTED CLOSURE OF OUR RANDOM POINT TRAVERSE WAS 1 PART IN 22,000, AND WAS ACCOMPLISHED USING A SOKKIA SET3100 TOTAL STATION, DURING THE MONTH OF MAY, 2002.
- DURING 2019, HIGHLAND SOILS (MICHAEL MARIANO, STATE OF NEW HAMPSHIRE CERTIFIED SOIL SCIENTIST #76) CONDUCTED AN ON-SITE WETLANDS DELINEATION OF THE SUBJECT PARCEL. WETLANDS WERE IDENTIFIED BASED ON THE TOWN OF BARRINGTON ZONING ORDINANCE (ARTICLE 9) AND ON STATE & FEDERAL CRITERIA OUTLINED IN THE "CORPS OF ENGINEERS WETLANDS DELINEATION MANUAL" (DEPT. OF THE ARMY, 1987). ON THIS SITE, WETLANDS BASED ON LOCAL CRITERIA SHARE THE SAME BOUNDARIES WITH THOSE BASED ON STATE AND FEDERAL CRITERIA.
- THE SUBJECT PARCEL IS NOT LOCATED WITHIN A FEDERALLY DESIGNATED SPECIAL FLOOD HAZARD ZONE (FLOOD HAZARD ZONE A - PANEL 0305E, MAP No. 33017C0305E, DATE: 9-30-2015).
- SEE SHORELAND PROTECTION DISTRICT OVERLAY (SDO), (BARRINGTON ZONING ORDINANCE ARTICLE 11)
- NHDES WETLANDS AND NON-SITE SPECIFIC PERMIT 2004-01983, EXPIRATION DATE: 09/28/2009.
- NHDES SUBDIVISION APPROVAL NO.: 2004005422 (TAX MAP 12 LOT 132), DATED 09/20/2004 & NHDES SUBDIVISION APPROVAL NO.: 2004005423 (TAX MAP 12 LOT 97D-15), DATED 08/20/2004.
- NHDOT DRIVEWAY PERMIT NO: 05-027-426, DATED SEPTEMBER 22, 2004.

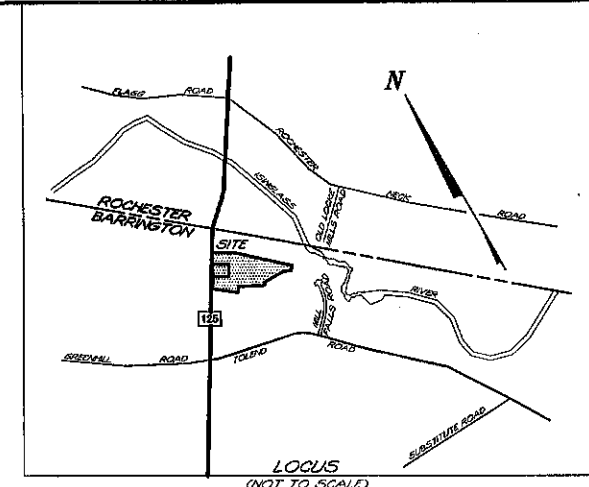
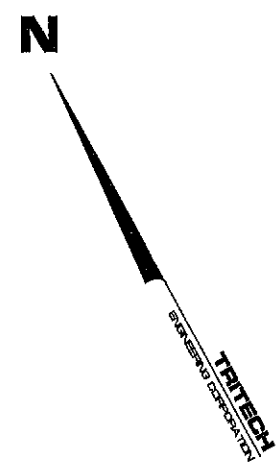

TRITECH
ENGINEERING CORPORATION

REVISIONS	DATE	DESCRIPTION:
1	12-2-18	REVISED PER PLANNING COMMENTS
2	5-28-20	REVISED PER CONDITIONS OF APPROVAL

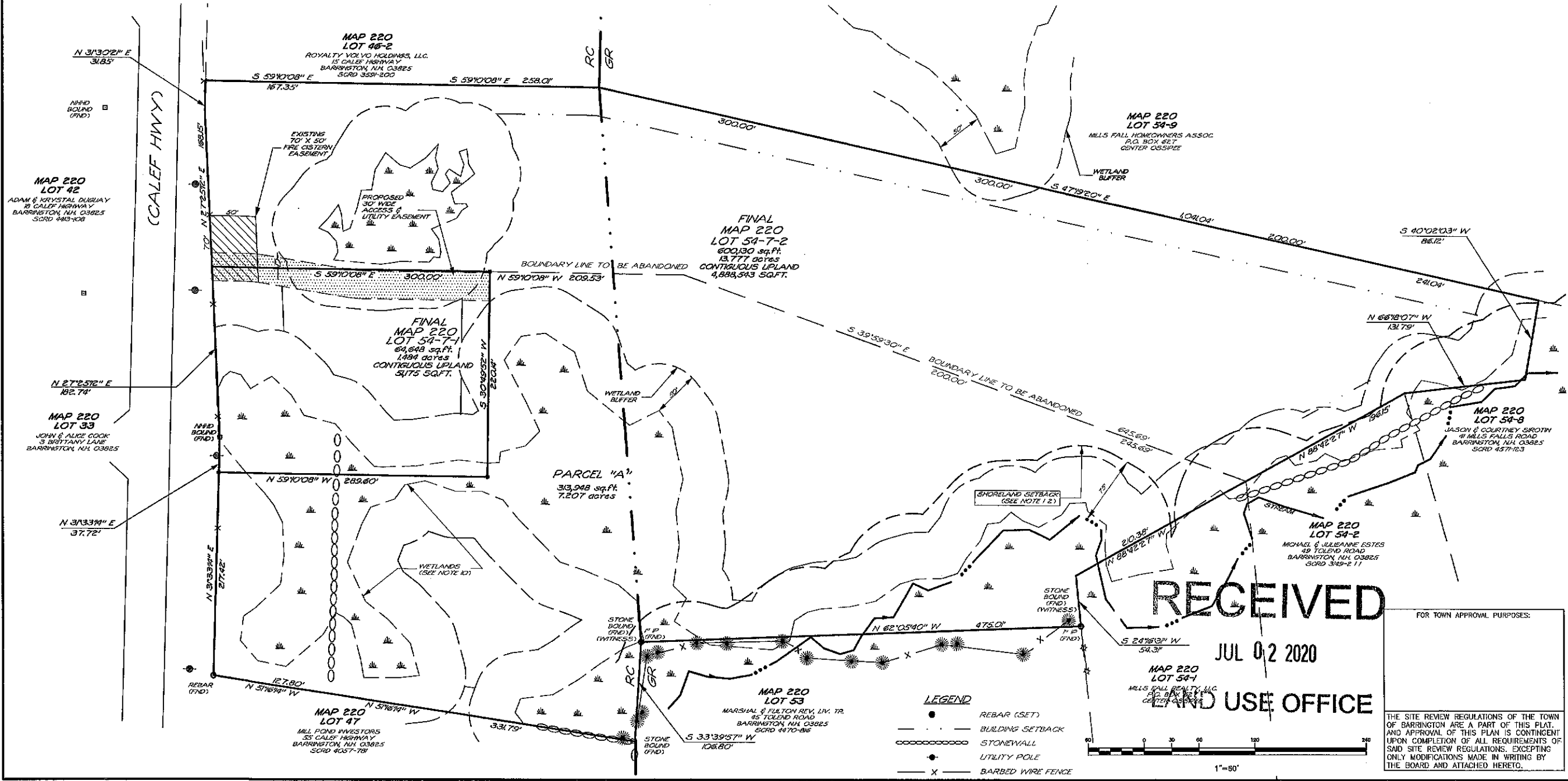
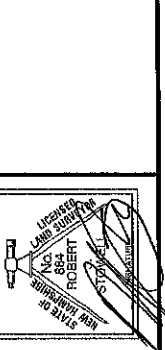

BOUNDARY LINE ADJUSTMENT PLAN
MILL FALLS REALTY, LLC.
MAP 220 LOTS 54-7-1 & 54-7-2
ROUTE #125
BARRINGTON, NEW HAMPSHIRE
NOVEMBER 11, 2019 JOB No. 19107
SCALE: 1" = 80'

SHEET No. **BLA-1**

FOR TOWN APPROVAL PURPOSES:
THE SITE REVIEW REGULATIONS OF THE TOWN OF BARRINGTON ARE A PART OF THIS PLAN, AND APPROVAL OF THIS PLAN IS CONTINGENT UPON COMPLETION OF ALL REQUIREMENTS OF SAID SITE REVIEW REGULATIONS, EXCEPTING ONLY MODIFICATIONS MADE IN WRITING BY THE BOARD AND ATTACHED HERETO.

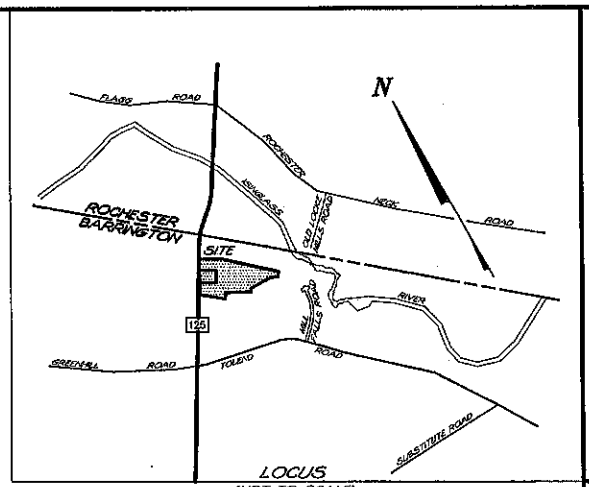
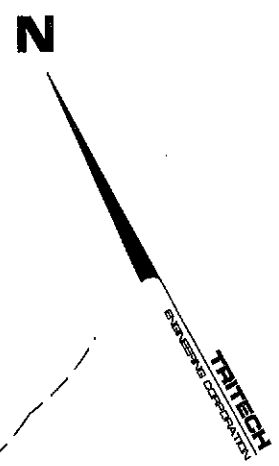
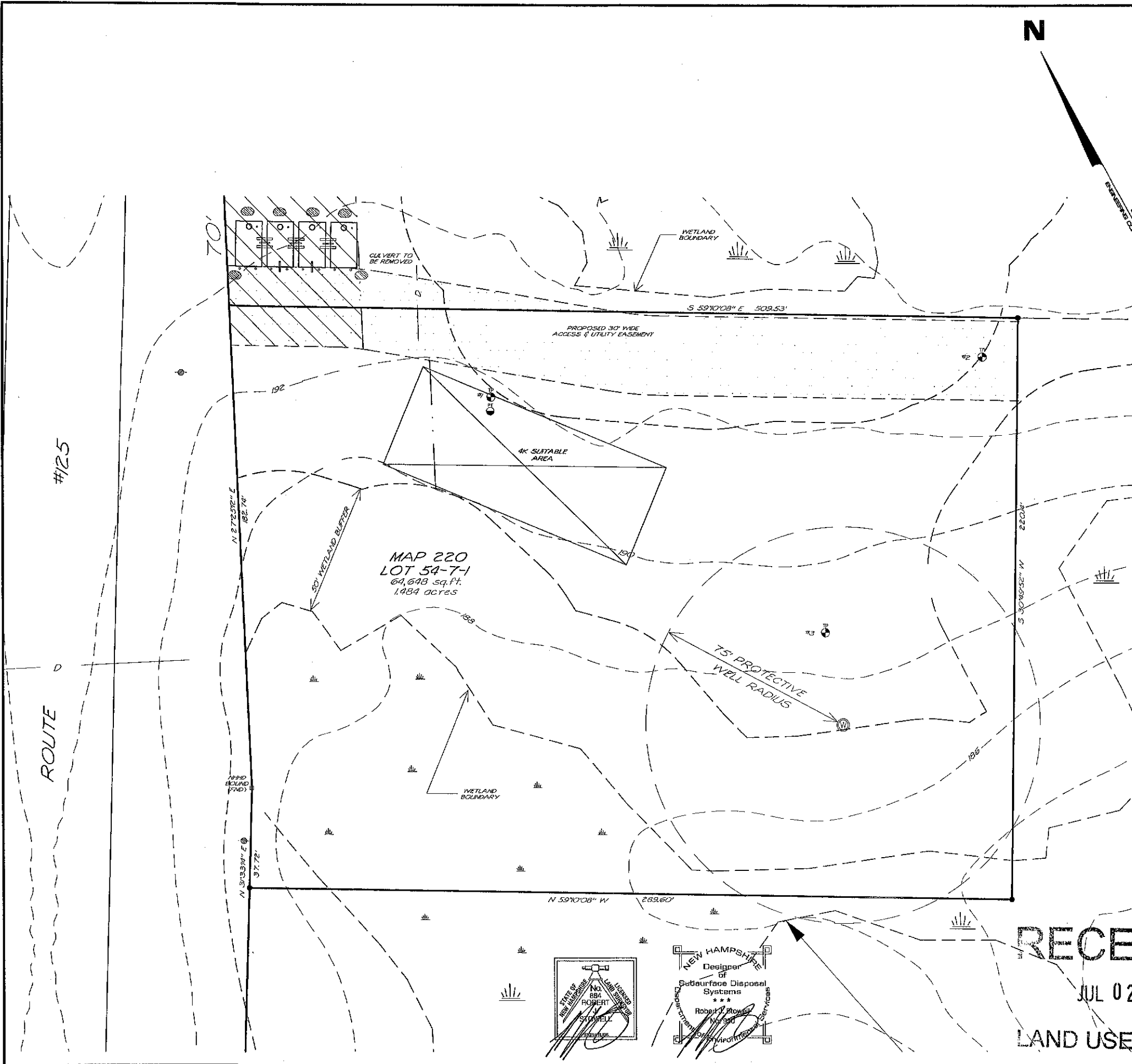

NOTES

- 1.) INTENT: TO SHOW THAT THE PROPOSED BARRINGTON TAX MAP 220 LOT 54-7-1 MEETS THE NHDES SUBDIVISION STANDARDS.
- 2.) CURRENT OWNER OF RECORD: MILL FALLS REALTY, LLC
P.O. BOX 627
CENTER OSSISPEE, N.H.
- 3.) TOTAL LOT AREA: 64,648 SQ.FT. - 1.484 ACRES
- 4.) TAX MAP 220 LOTS 54-7-1.
- 5.) PROJECT DEED REFERENCE: BOOK 2821 PAGE 327
- 6.) PROJECT PLAN REFERENCE: BOUNDARY LINE ADJUSTMENT AND SUBDIVISION PLAN
MILL FALL REALTY, LLC & DOROTHY A. PURVIS
REVOCABLE LIVING TRUST
ROUTE 125 & MILL FALLS ROAD
BARRINGTON, NEW HAMPSHIRE
TRITECH ENGINEERING CORPORATION
MAY 19, 2004 SCRD 77-22
- 7.) BASIS OF BEARING: BEARING SYSTEM BASED ON GPS FIELD OBSERVATIONS ON MARCH 28, 2019 USING TOPCON HIPER SR RECEIVERS AND OPUS CORRECTED ON APRIL 1, 2019. DATUM BASED ON NEW HAMPSHIRE STATE PLANE COORDINATES SPC (2800 NH), (VERTICAL DATUM: NAVD 88).
- 8.) ZONING: REGIONAL COMMERCIAL - RC GENERAL RESIDENTIAL - GR
MIN. LOT SIZE: 40,000 SQ.FT. MIN. LOT SIZE: 80,000 SQ.FT.
MIN. FRONTAGE: 200 FT. MIN. FRONTAGE: 200 FT.
MIN. SETBACKS: MIN. SETBACKS:
FRONT: 75 FT FRONT: 40 FT
SIDE: 30 FT SIDE: 30 FT
REAR: 30 FT REAR: 30 FT
OVERLAY DISTRICTS: GROUNDWATER PROTECTION (STRATIFIED DRIFT AQUIFER),
- 9.) THE RAW UNADJUSTED CLOSURE OF OUR RANDOM POINT TRAVERSE WAS 1 PART IN 22,000, AND WAS ACCOMPLISHED USING A SOKKIA SET3100 TOTAL STATION, DURING THE MONTH OF MAY, 2002.
- 10.) DURING 2019, HIGHLAND SOILS (MICHAEL MARIANO, STATE OF NEW HAMPSHIRE CERTIFIED SOIL SCIENTIST #76) CONDUCTED AN ON-SITE WETLANDS DELINEATION OF THE SUBJECT PARCEL. WETLANDS WERE IDENTIFIED BASED ON THE TOWN OF BARRINGTON ZONING ORDINANCE (ARTICLE 9) AND ON STATE & FEDERAL CRITERIA OUTLINED IN THE "CORPS OF ENGINEERS WETLANDS DELINEATION MANUAL" (DEPT. OF THE ARMY, 1987). ON THIS SITE, WETLANDS BASED ON LOCAL CRITERIA SHARE THE SAME BOUNDARIES WITH THOSE BASED ON STATE AND FEDERAL CRITERIA.
- 11.) THE SUBJECT PARCEL IS NOT LOCATED WITHIN A FEDERALLY DESIGNATED SPECIAL FLOOD HAZARD ZONE (FLOOD HAZARD ZONE A - PANEL 0305E, MAP No. 33017C0305E, DATE: 9-30-2015).
- 12.) SEE SHORELAND PROTECTION DISTRICT OVERLAY (SDO), (BARRINGTON ZONING ORDINANCE ARTICLE 11)
- 13.) NHDES WETLANDS AND NON-SITE SPECIFIC PERMIT 2004-01983, EXPIRATION DATE: 09/28/2009.
- 14.) NHDES SUBDIVISION APPROVAL NO.: 2004005422 (TAX MAP 12 LOT 132), DATED 09/20/2004 & NHDES SUBDIVISION APPROVAL NO.: 2004005423 (TAX MAP 12 LOT 97D-15), DATED 09/20/2004.
- 15.) NHDOT DRIVEWAY PERMIT NO: 06-027-426, DATED SEPTEMBER 22, 2004.

LEGEND

●	REBAR (SET)
○	STONEWALL
◆	UTILITY POLE
---	CONTOUR
⊕	PROPOSED WELL
---	WETLAND BOUNDARY
---	WETLAND SETBACK
⊙	TEST PIT
⊕	PERC TEST

RECEIVED

JUL 02 2020

LAND USE OFFICE

1"=20'

TRITECH
ENGINEERING CORPORATION

REVISIONS	DATE	DESCRIPTION
12-2-19		REVISED PER PLANNING COMMENTS
11-28-20		GENERAL REVISIONS

NHDES SUBDIVISION PLAN

MILL FALLS REALTY, LLC.

ROUTE #125

BARRINGTON, NEW HAMPSHIRE

NOVEMBER 14, 2019 JOB No. 19107

SCALE: 1" = 20'

SHEET No.

NHDES
1

785 CENTRAL AVENUE
DOVER, NEW HAMPSHIRE 03800
TELEPHONE 603 745 8407
FAX 603 742 4580

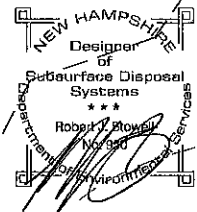
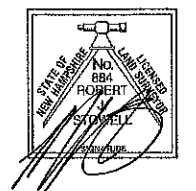

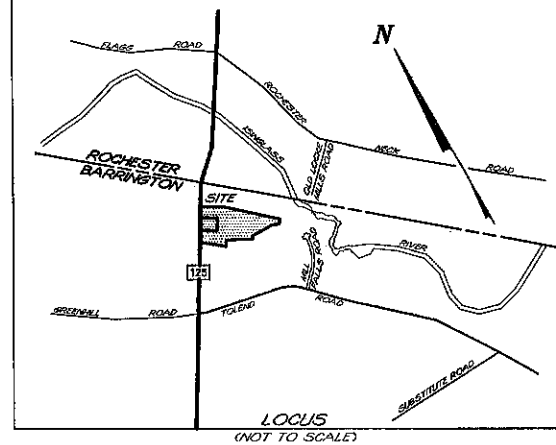
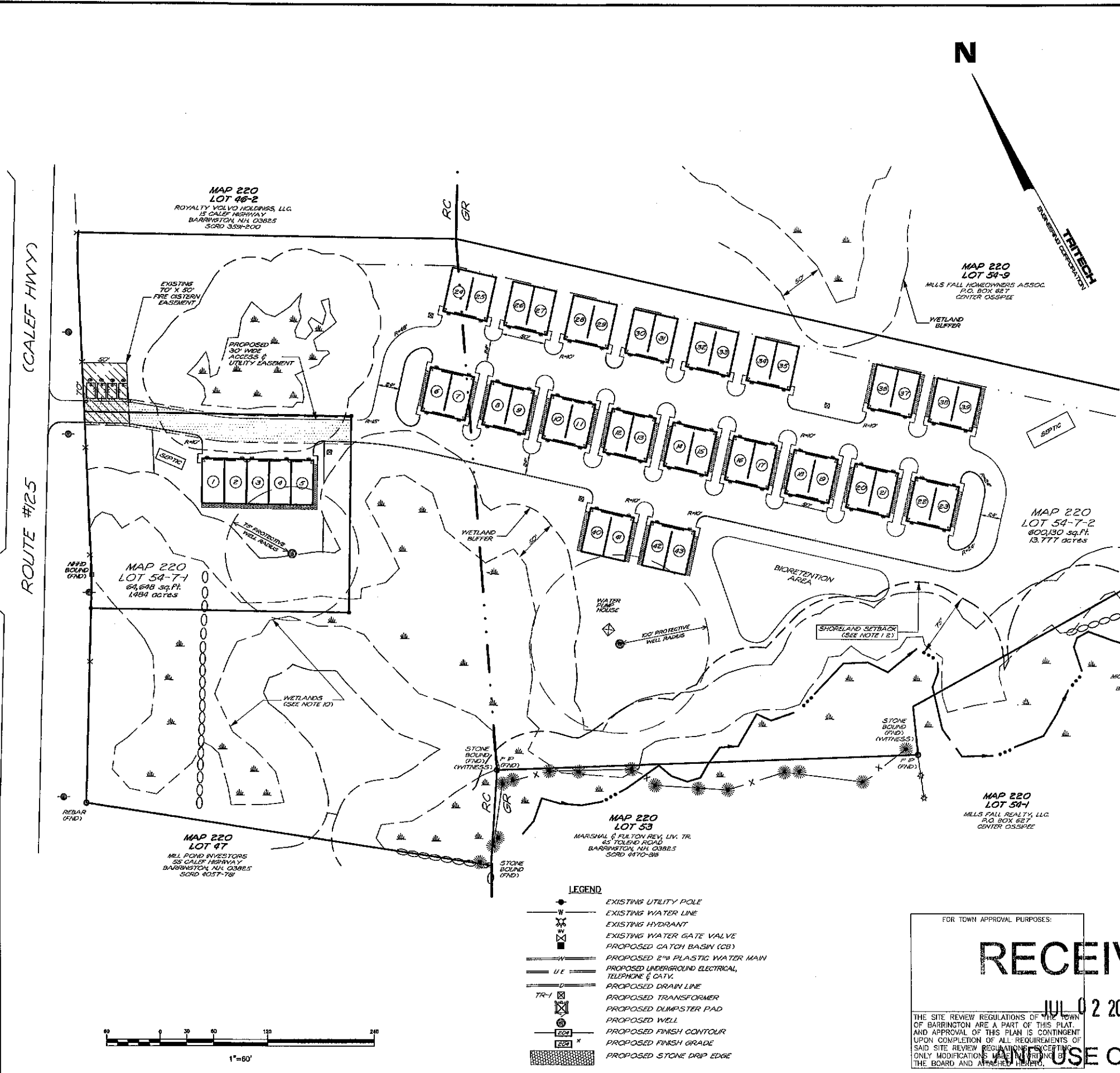

NOTES

- INTENT: TO SHOW THE PROPOSED DEVELOPMENT OF BARRINGTON TAX MAP 220 LOTS 54-7-1 & 54-7-2, SPECIFICALLY: 43 COMMERCIAL STORAGE-OFFICE UNITS WITH ASSOCIATED INFRASTRUCTURE AND UTILITIES.
- CURRENT OWNER OF RECORD: MILL FALLS REALTY, LLC P.O. BOX 927 CENTER OSSISPEE, N.H. APPLICANT: MILL FALLS REALTY, LLC P.O. BOX 927 CENTER OSSISPEE, N.H.
- TOTAL LOT AREA: MAP 220 LOT 54-7-1 64,648 SQ.FT. - 1.484 ACRES MAP 220 LOT 54-7-2 600,130 SQ.FT. - 13.777 ACRES
- TAX MAP 220 LOTS 54-7-1 & 54-7-2
- PROJECT DEED REFERENCE: BOOK 2821 PAGE 327
- PROJECT PLAN REFERENCE: BOUNDARY LINE ADJUSTMENT AND SUBDIVISION PLAN MILL FALL REALTY, LLC & DOROTHY A. PURVIS REVOCABLE LIVING TRUST ROUTE 125 & MILL FALLS ROAD BARRINGTON, NEW HAMPSHIRE TRITECH ENGINEERING CORPORATION MAY 19, 2004 SCRD 77-22
- BASIS OF BEARING: BEARING SYSTEM BASED ON GPS FIELD OBSERVATIONS ON MARCH 28, 2019 USING TOPCON HIFER SR RECEIVERS AND OPUS CORRECTED ON APRIL 1, 2019. DATUM BASED ON NEW HAMPSHIRE STATE PLANE COORDINATES SPC (2800 NH), (VERTICAL DATUM: NAVD 88).
- ZONING: REGIONAL COMMERCIAL - RC GENERAL RESIDENTIAL -GR
 MIN. LOT SIZE: 40,000 SQ.FT. MIN. LOT SIZE: 80,000 SQ.FT.
 MIN. FRONTAGE: 200 FT. MIN. FRONTAGE: 200 FT.
 MIN. SETBACKS: FRONT: 75 FT. SIDE: 30 FT. REAR: 30 FT.
 OVERLAY DISTRICTS: GROUNDWATER PROTECTION (STRATIFIED DRIFT AQUIFER).
- THE RAW UNADJUSTED CLOSURE OF OUR RANDOM POINT TRAVERSE WAS 1 PART IN 22,000, AND WAS ACCOMPLISHED USING A SOKKIA SET3100 TOTAL STATION, DURING THE MONTH OF MAY, 2002.
- DURING 2019, HIGHLAND SOILS (MICHAEL MARIANO, STATE OF NEW HAMPSHIRE CERTIFIED SOIL SCIENTIST #76) CONDUCTED AN ON-SITE WETLANDS DELINEATION OF THE SUBJECT PARCEL. WETLANDS WERE IDENTIFIED BASED ON THE TOWN OF BARRINGTON ZONING ORDINANCE (ARTICLE 9) AND ON STATE & FEDERAL CRITERIA OUTLINED IN THE "CORPS OF ENGINEERS WETLANDS DELINEATION MANUAL" (DEPT. OF THE ARMY, 1987). ON THIS SITE, WETLANDS BASED ON LOCAL CRITERIA SHARE THE SAME BOUNDARIES WITH THOSE BASED ON STATE AND FEDERAL CRITERIA.
- THE SUBJECT PARCEL IS NOT LOCATED WITHIN A FEDERALLY DESIGNATED SPECIAL FLOOD HAZARD ZONE (FLOOD HAZARD ZONE A - PANEL 0305E, MAP No. 33017C0305E, DATE: 9-30-2015).
- SEE SHORELAND PROTECTION DISTRICT OVERLAY (SDO), (BARRINGTON ZONING ORDINANCE ARTICLE 11)
- NHDES WETLANDS AND NON-SITE SPECIFIC PERMIT 2004-01983, EXPIRATION DATE: 09/28/2009.
- NHDES SUBDIVISION APPROVAL NO.: 2004005422 (TAX MAP 12 LOT 132), DATED 09/20/2004 & NHDES SUBDIVISION APPROVAL NO.: 2004005423 (TAX MAP 12 LOT 97D-15), DATED 09/20/2004.
 NHDES BIA APPROVAL NO.: PENDING
 NHDES ISDS APPROVAL NO. (TAX MAP 220 LOT 54-7-1): PENDING
 NHDES ISDS APPROVAL NO. (TAX MAP 220 LOT 54-7-2): PENDING
 NHDES AOT APPROVAL NO.: 20200605-079: PENDING
- NHDOT DRIVEWAY PERMIT NO: 06-027-426, DATED SEPTEMBER 22, 2004.
- LOTS ARE SERVICED BY PRIVATE WATER AND PRIVATE INDIVIDUAL SEWAGE DISPOSAL SYSTEMS.
- PARKING REQUIREMENTS OUTLINED IN SECTION 4.9.
 REQUIRED PARKING SPACES PER EACH UNIT:
 250 SQ.FT. OFFICE 1 PER 300 = 1 SPACE
 1,000 SQ.FT. WAREHOUSE 1 PER 1000 = 1 SPACE
 TOTAL REQUIRED PARKING SPACES PER UNIT = 2 SPACES
 MINIMUM PARKING SPACES PROVIDED PER UNIT = 2 SPACES (UNSTRIPED)
- LOT COVERAGE: ALLOWABLE: 50% PROVIDED:
 MAP 220 LOT 54-7-1 24%
 MAP 220 LOT 54-7-2 19%
- CONSTRUCTION TIMETABLE: CONSTRUCTION IS EXPECTED TO BEGIN UPON APPROVALS WITH A MULTI-YEAR BUILD OUT ANTICIPATED.
- IN ACCORDANCE WITH TOWN REGULATIONS AND RSA 676:13, ALL IMPROVEMENTS SPECIFIED ON THESE SITE PLANS SHALL BE CONSTRUCTED, COMPLETED, INSPECTED AND APPROVED BY THE TOWN OF BARRINGTON PRIOR TO THE ISSUANCE OF A CERTIFICATE OF OCCUPANCY.

LEGEND

	EXISTING UTILITY POLE
	EXISTING WATER LINE
	EXISTING HYDRANT
	EXISTING WATER GATE VALVE
	PROPOSED CATCH BASIN (CB)
	PROPOSED 2" PLASTIC WATER MAIN
	PROPOSED UNDERGROUND ELECTRICAL, TELEPHONE & CATV.
	PROPOSED DRAIN LINE
	PROPOSED TRANSFORMER
	PROPOSED DUMPSTER PAD
	PROPOSED WELL
	PROPOSED FINISH CONTOUR
	PROPOSED FINISH GRADE
	PROPOSED STONE DRIP EDGE

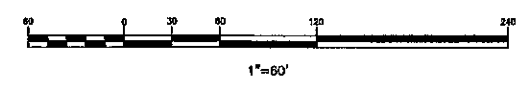

FOR TOWN APPROVAL PURPOSES:

RECEIVED

JUL 02 2020

PLANNING USE OFFICE

THE SITE REVIEW REGULATIONS OF THE TOWN OF BARRINGTON ARE A PART OF THIS PLAN AND APPROVAL OF THIS PLAN IS CONTINGENT UPON COMPLETION OF ALL REQUIREMENTS OF SAID SITE REVIEW REGULATIONS EXCEPTING ONLY MODIFICATIONS MADE BY THE BOARD AND ATTACHED HERETO.

TRITECH
ENGINEERING CORPORATION

785 CENTRAL AVENUE
DOVER NEW HAMPSHIRE 03801
TELEPHONE 603 748 8107
FAX 603 748 8830

REVISIONS	DATE	DESCRIPTION
12-2-19	12-2-19	REVISION PER PLANNING COMMENTS
5-28-20	5-28-20	GENERAL REVISIONS
6-30-20	6-30-20	REVISED PER PER REVIEW

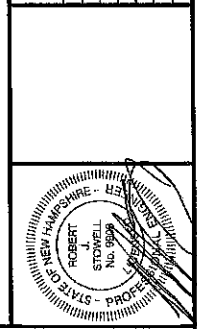

GENERAL SITE PLAN
BARRINGTON STORAGE-OFFICE
ROUTE #125
BARRINGTON, NEW HAMPSHIRE

NOVEMBER 11, 2019 JOB No. 19107
SCALE: 1" = 60'

SHEET NO.

SP-1

N

MAP 220
LOT 46-2
ROYALTY VOLVO HOLDINGS, LLC.
15 CALEF HIGHWAY
BARRINGTON, N.H. 03825
SCRD 3591-200

ROUTE #125
(CALEF HWY)

ROUTE #125

MAP 220
LOT 54-7-1
64,648 sq.ft.
1.484 acres

NHHD
BOUND
(FND)

SEPTIC

WETLAND
BUFFER

GC-1 GENERAL CONSTRUCTION NOTES:

1. THE CONTRACTOR IS REQUIRED UNDER NEW HAMPSHIRE LAW TO CONTACT "DIG SAFE" AT 1-800-225-4977, 72 HOURS PRIOR TO THE START OF CONSTRUCTION. THE CONTRACTOR SHALL MAINTAIN THE "DIG SAFE" LOCATIONS THROUGHOUT THE DURATION OF THE PROJECT. THE CONTRACTOR SHALL BEAR THE COST TO REPAIR ANY UTILITIES DAMAGED DURING THE COURSE OF THE WORK.
2. EXISTING UTILITIES - ALL INFORMATION ON, AND LOCATION OF, EXISTING UTILITIES ARE APPROXIMATE AND BASED ON FIELD INFORMATION AND AVAILABLE PLANS. EXACT LOCATIONS AND DEPTHS TO BE VERIFIED BY THE CONTRACTOR PRIOR TO CONSTRUCTION.
3. AS-BUILT PLANS OF THE SITE SHALL BE SUBMITTED ON PAPER AND IN DIGITAL FORMAT IN PDF AND AUTOCAD DWG, AUTOCAD DXF OR AN ESRI FORMAT TO THE TOWN OF BARRINGTON ENGINEER'S OFFICE UPON COMPLETION OF THE PROJECT. AS-BUILT PLANS SHALL BE PREPARED AND CERTIFIED CORRECT BY A L.L.S. OR P.E. DIGITAL FILES SHALL BE GEO-REFERENCED TO NEW HAMPSHIRE STATE PLANE COORDINATES NAD 83 AND SHALL BE EXPRESSED IN FEET.
4. ALL BACKFILL IN TRENCHES AND FILL FOR ROADBEDS SHALL BE THOROUGHLY COMPACTED TO 95% OF OPTIMUM DENSITY.
5. TOPOGRAPHIC SURVEY PERFORMED BY TRITECH ENGINEERING CORPORATION IN SEPTEMBER, 2019 AND ELEVATIONS ARE BASED ON U.S.G.S. DATUM.
6. THE INSTALLATION OF ELECTRIC POWER, CABLE TELEVISION AND TELEPHONE LINES SHALL BE UNDERGROUND THROUGHOUT THE SITE FOR WHICH DEVELOPMENT IS PROPOSED.
7. ALL CONSTRUCTION SHALL CONFORM WITH THE STATE OF NEW HAMPSHIRE DEPARTMENT OF TRANSPORTATION (NHDOT) "STANDARD SPECIFICATIONS FOR ROAD AND BRIDGE CONSTRUCTION".
8. IF, DURING CONSTRUCTION, IT BECOMES APPARENT THAT DEFICIENCIES EXIST IN THE APPROVED DESIGN DRAWINGS, THE CONTRACTOR SHALL BE REQUIRED TO CORRECT THE DEFICIENCIES TO MEET THE REQUIREMENTS OF THE REGULATIONS AT NO EXPENSE TO THE TOWN.
9. REQUIRED EROSION CONTROL MEASURES SHALL BE INSTALLED PRIOR TO ANY DISTURBANCE OF THE SITE'S SURFACE AREA AND SHALL BE MAINTAINED THROUGH THE COMPLETION OF ALL CONSTRUCTION ACTIVITIES. IF, DURING CONSTRUCTION, IT BECOMES APPARENT THAT ADDITIONAL EROSION CONTROL MEASURES ARE REQUIRED TO STOP ANY EROSION ON THE CONSTRUCTION SITE DUE TO ACTUAL SITE CONDITIONS, THE OWNER SHALL BE REQUIRED TO INSTALL THE NECESSARY EROSION PROTECTION AT NO EXPENSE TO THE TOWN.
10. SHEETS T-1, T-2, EX-1, SSS-1, SSS-2, BLA-1, NHDS-1, SP-1 THRU SP-9, ISDS-1 THRU ISDS-2, C-1, C-2, C-3, SPP-1, CIR-1, LI-1, LI-1A, LA-1, LA-1A AND LA-2 ARE PART OF THIS APPROVAL. SHEET BLA-1 TO BE RECORDED.
11. ALL MATERIALS AND METHODS OF CONSTRUCTION SHALL CONFORM TO TOWN OF BARRINGTON SITE REVIEW REGULATIONS AND THE LATEST EDITION OF THE NEW HAMPSHIRE DEPARTMENT OF TRANSPORTATION'S STANDARD SPECIFICATIONS FOR ROAD & BRIDGE CONSTRUCTION.
12. ALL PROPOSED DRAINAGE PIPES TO BE HIGH-DENSITY POLYETHYLENE, DUAL WALL N-12 CORRUGATED PIPE IN ACCORDANCE WITH BARRINGTON SITE PLAN REVIEW REGULATIONS 4.7.7(5).

C-1 CONSTRUCTION NOTES:

1. INSTALL SILT FENCE PER DETAIL 1, SHEET SP-6 OR FILTER SOCK PER DETAIL 7, SHEET SP-6.
2. NOT USED
3. INSTALL SLOPED GRANITE CURB PER DETAIL 4, SHEET SP-5.
4. INSTALL STABILIZED CONSTRUCTION ENTRANCE PER DETAIL 5, SHEET SP-6.
5. SAWCUT PAVEMENT, PATCH AND MATCH EXISTING PAVEMENT PER DETAIL 11, SHEET SP-5.
6. INSTALL (43) BEDA MODEL 33542 WALL MOUNTED LIGHT FIXTURE. MOUNTING HEIGHT SHALL BE 10 FEET ABOVE FINISH GRADE.
7. INSTALL 125' OF BUILDING DRIP-EDGE PER DETAIL 10, SHEET SP-5.
8. INSTALL FIRE CISTERN PER DETAIL 1, SHEET SP-5.

LEGEND

	EXISTING UTILITY POLE
	PROPOSED 2" PLASTIC WATER MAIN
	PROPOSED UNDERGROUND ELECTRICAL, TELEPHONE & CATV
	PROPOSED DRAIN LINE
	EXTERIOR ENTRANCE
	OVERHEAD DOOR
	PROPOSED STONE DRIP EDGE

RECEIVED

JUL 02 2020

LAND USE OFFICE
1"=30'

FOR TOWN APPROVAL PURPOSES:

THE SITE REVIEW REGULATIONS OF THE TOWN OF BARRINGTON ARE A PART OF THIS PLAN. APPROVAL OF THIS PLAN IS CONTINGENT UPON COMPLETION OF ALL REQUIREMENTS OF SAID SITE REVIEW REGULATIONS, EXCEPTING ONLY MODIFICATIONS MADE IN WRITING BY THE BOARD AND ATTACHED HERETO.

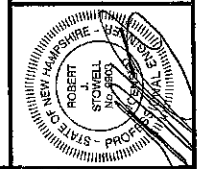

TRITECH
ENGINEERING CORPORATION

765 CENTRAL AVENUE
COVER NEW HAMPSHIRE 03860
TELEPHONE 603 742 8107
FAX 603 742 8530

SITE DEVELOPMENT PLAN
BARRINGTON
STORAGE-OFFICE
ROUTE #125
BARRINGTON, NEW HAMPSHIRE

NOVEMBER 11, 2019 JOB No. 19107
SCALE: 1" = 30'

SHEET NO.

SP-2

MAP 220
 LOT 54-9
 MILLS FALL HOMEOWNERS ASSOC.
 P.O. BOX 627
 CENTER OSSIPEE

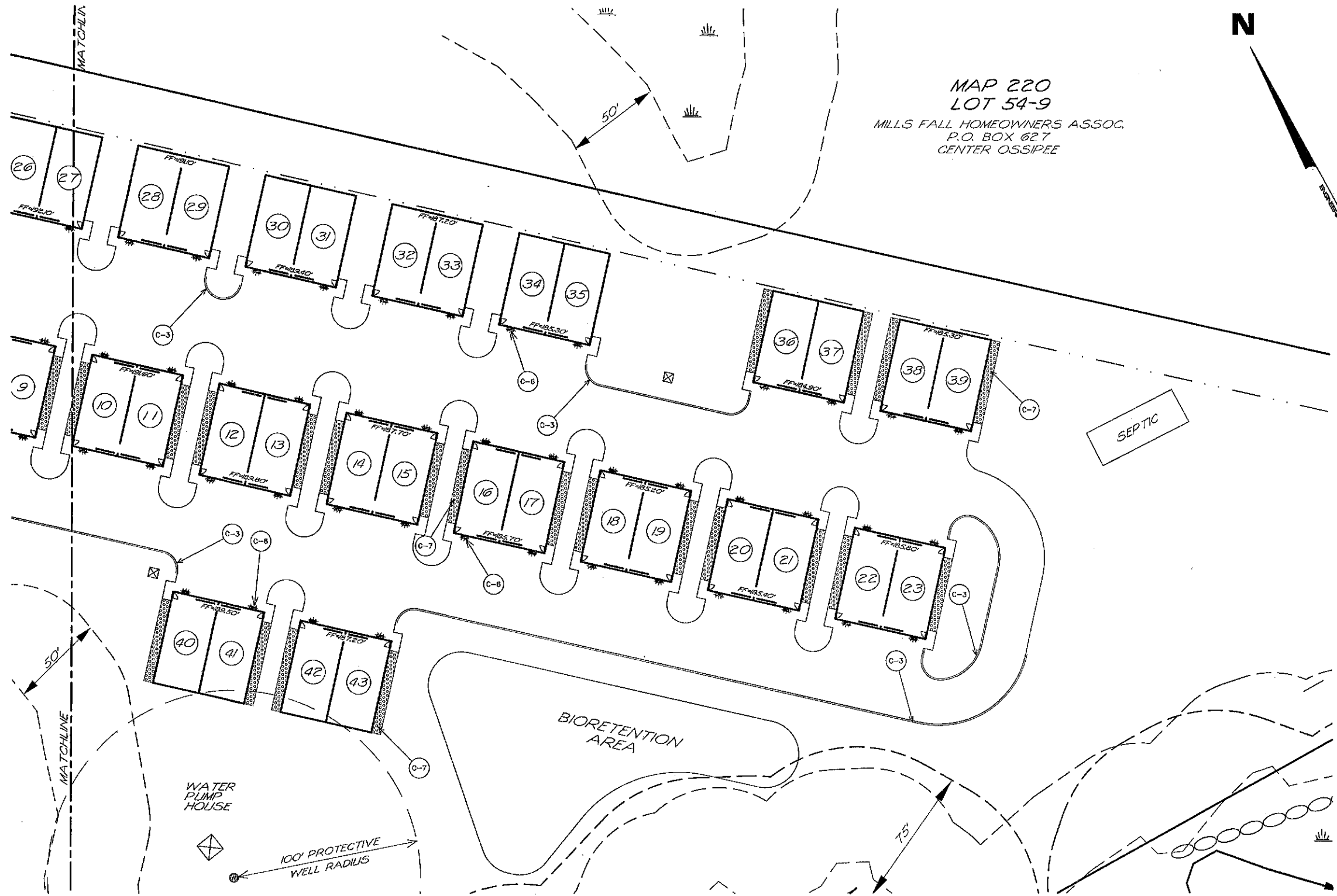
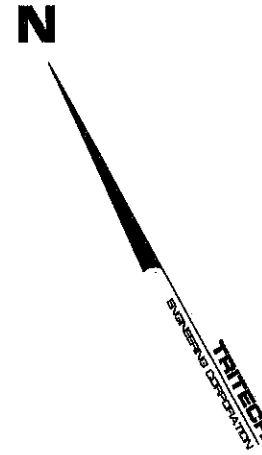

- LEGEND**
- EXISTING UTILITY POLE
 - W— PROPOSED 2" PLASTIC WATER MAIN
 - U/E— PROPOSED UNDERGROUND ELECTRICAL, TELEPHONE & CATV.
 - D— PROPOSED DRAIN LINE
 - ▽— EXTERIOR ENTRANCE
 - OVERHEAD DOOR
 - PROPOSED STONE DRIP EDGE

RECEIVED

JUL 02 2020

LAND USE OFFICE

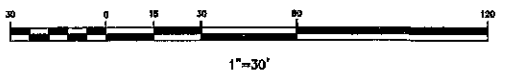

FOR TOWN APPROVAL PURPOSES:

THE SITE REVIEW REGULATIONS OF THE TOWN OF BARRINGTON ARE A PART OF THIS PLAN, AND APPROVAL OF THIS PLAN IS CONTINGENT UPON COMPLETION OF ALL REQUIREMENTS OF SAID SITE REVIEW REGULATIONS, EXCEPTING ONLY MODIFICATIONS MADE IN WRITING BY THE BOARD AND ATTACHED HERETO.

TRITECH
 ENGINEERING CORPORATION

788 CENTRAL AVENUE
 COVER NEW HAMPSHIRE 03800
 TELEPHONE 603 748 8107
 FAX 603 748 8180

REVISIONS	DATE	DESCRIPTION:
12-2-18	REVISION PER PLANNING COMMENTS	
5-28-20	GENERAL REVISIONS	
6-29-20	REVISION PER PEER REVIEW	

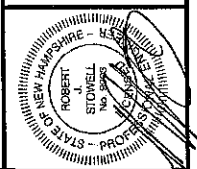

SITE DEVELOPMENT PLAN

**BARRINGTON
 STORAGE-OFFICE**

ROUTE #125
 BARRINGTON, NEW HAMPSHIRE

NOVEMBER 11, 2019 JOB No. 19107
 SCALE: 1" = 30'

SHEET NO.

SP-2A

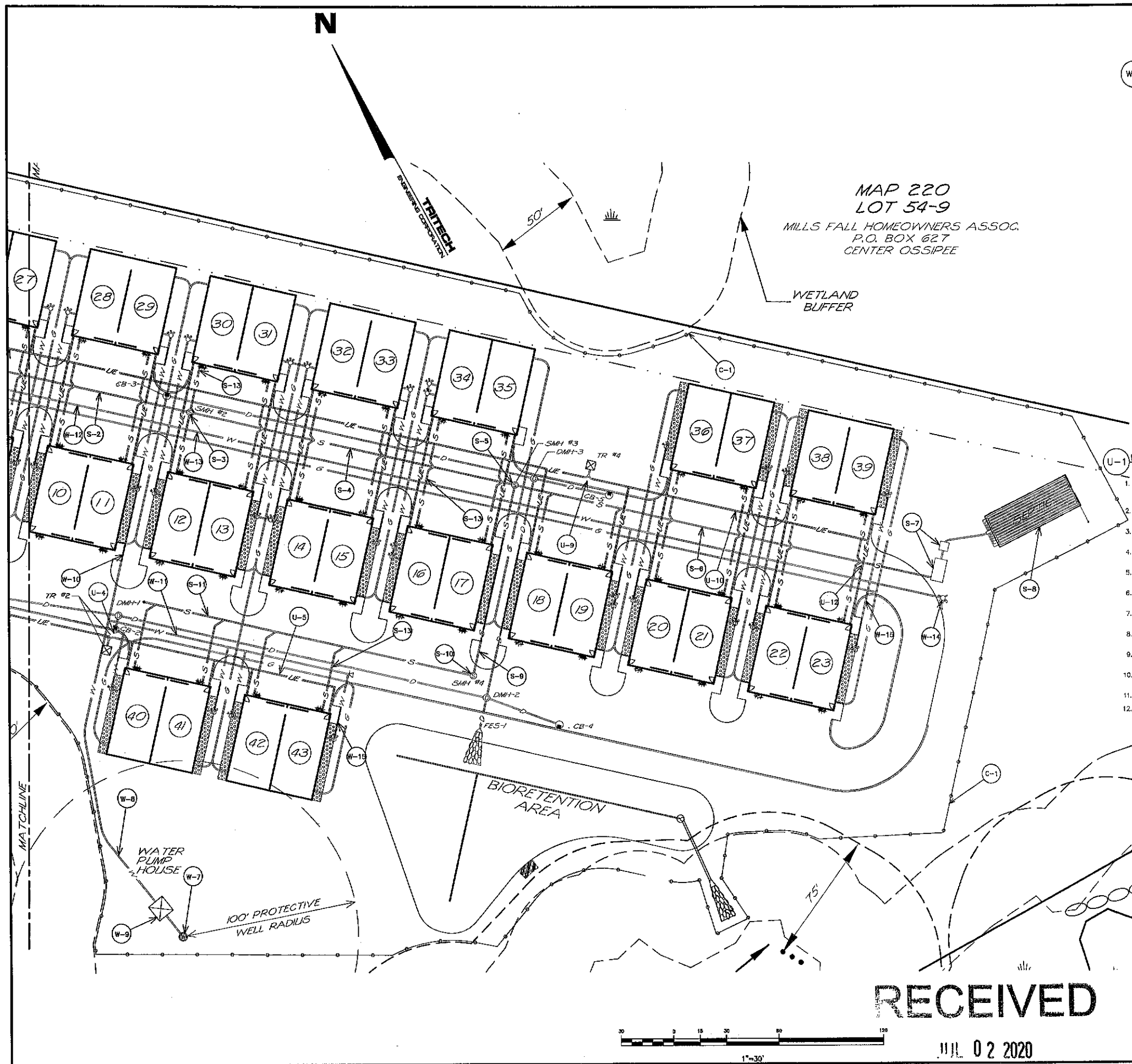

MAP 220
LOT 54-9
MILLS FALL HOMEOWNERS ASSOC.
P.O. BOX 627
CENTER OSSISPEE

WATER NOTES:

1. WATERLINE AND APPENDICES, INSTALLATION, AND MATERIALS SHALL CONFORM WITH THE AMERICAN WATER WORKS STANDARDS.
2. PRESSURE AND LEAKAGE TEST SHALL BE PERFORMED IN ACCORDANCE WITH THE LATEST STANDARDS OF AWWA. CHLORINATING AND FLUSHING SHALL BE COMPLETED IN ACCORDANCE WITH THE LATEST STANDARDS OF AWWA, STATE AND LOCAL REGULATIONS.
3. BACKFLOW PREVENTORS SHALL BE PROVIDED FOR ALL WATER LINES.
4. DRILL ARTISIAN WELL.
5. INSTALL 50' - 2" TYPE K COPPER OR 2" PLASTIC (MEETING AAWA STANDARDS) WATER LINE FROM WELL TO SHUT-OFF. MINIMUM DEPTH OF COVER OVER PIPE = 5.5'.
6. INSTALL 100' - 2" TYPE K COPPER OR 2" PLASTIC (MEETING AAWA STANDARDS) WATER LINE FROM SHUT-OFF TO SHUT-OFF. MINIMUM DEPTH OF COVER OVER PIPE = 5.5'.
7. DRILL ARTISIAN WELL. PUMP STATION DESIGN BY OTHERS.
8. INSTALL 170' - 2" TYPE K COPPER OR 2" PLASTIC (MEETING AAWA STANDARDS) WATER LINE FROM WELL TO WATER PUMP HOUSE. MINIMUM DEPTH OF COVER OVER PIPE = 5.5'.
9. INSTALL WATER PUMP HOUSE. PUMP STATION DESIGN BY OTHERS.
10. INSTALL 170' - 2" TYPE K COPPER OR 2" PLASTIC (MEETING AAWA STANDARDS) WATER LINE FROM WATER PUMP HOUSE TO THE INTERSECTION. MINIMUM DEPTH OF COVER OVER PIPE = 5.5'.
11. INSTALL 140' - 2" TYPE K COPPER OR 2" PLASTIC (MEETING AAWA STANDARDS) WATER LINE FROM WATER LINE TO THE END. MINIMUM DEPTH OF COVER OVER PIPE = 5.5'.
12. INSTALL 200' - 2" TYPE K COPPER OR 2" PLASTIC (MEETING AAWA STANDARDS) WATER LINE FROM WATER LINE TO THE END. MINIMUM DEPTH OF COVER OVER PIPE = 5.5'.
13. INSTALL 480' - 2" TYPE K COPPER OR 2" PLASTIC (MEETING AAWA STANDARDS) WATER LINE FROM WATER LINE TO THE PROPOSED HYDRANT. MINIMUM DEPTH OF COVER OVER PIPE = 5.5'.
14. INSTALL YARD HYDRANT.
15. INSTALL 2" TYPE K COPPER OR 2" PLASTIC (MEETING AAWA STANDARDS) WATER SERVICE FROM WATER LINE TO THE BUILDING. MINIMUM DEPTH OF COVER OVER PIPE = 5.5'.

UTILITY NOTES:

1. INSTALL 275 FT OF UNDERGROUND CONDUIT IN ACCORDANCE WITH EVERSOURCE STANDARDS & DETAIL 12, (TRENCH "A"), DETAIL 4, SHEET SP-7 FROM EXISTING UTILITY POLE TO TRANSFORMER 1. (PRIMARY POWER)
2. INSTALL TRANSFORMER 1 AND CONCRETE PAD (SUITABLE FOR A 100 KW TRANSFORMER), IN ACCORDANCE WITH EVERSOURCE STANDARDS.
3. INSTALL 300 FT OF UNDERGROUND CONDUIT IN ACCORDANCE WITH EVERSOURCE STANDARDS & DETAIL 12, (TRENCH "A"), DETAIL 4, SHEET SP-7 FROM TRANSFORMER 1 TO TRANSFORMER 2. (PRIMARY POWER)
4. INSTALL TRANSFORMER 2 AND CONCRETE PAD (SUITABLE FOR A 100 KW TRANSFORMER), IN ACCORDANCE WITH EVERSOURCE STANDARDS.
5. INSTALL 125 FT OF UNDERGROUND CONDUIT IN ACCORDANCE WITH EVERSOURCE STANDARDS & DETAIL 12, (TRENCH "A"), DETAIL 4, SHEET SP-7 FROM TRANSFORMER 2 TO THE END.
6. INSTALL 210 FT OF UNDERGROUND CONDUIT IN ACCORDANCE WITH EVERSOURCE STANDARDS & DETAIL 12, (TRENCH "A"), DETAIL 4, SHEET SP-7 FROM TRANSFORMER 1 TO TRANSFORMER 3. (PRIMARY POWER)
7. INSTALL TRANSFORMER 3 AND CONCRETE PAD (SUITABLE FOR A 100 KW TRANSFORMER), IN ACCORDANCE WITH EVERSOURCE STANDARDS.
8. INSTALL 450 FT OF UNDERGROUND CONDUIT IN ACCORDANCE WITH EVERSOURCE STANDARDS & DETAIL 12, (TRENCH "A"), DETAIL 4, SHEET SP-7 FROM TRANSFORMER 3 TO TRANSFORMER 4. (PRIMARY POWER)
9. INSTALL TRANSFORMER 4 AND CONCRETE PAD (SUITABLE FOR A 100 KW TRANSFORMER), IN ACCORDANCE WITH EVERSOURCE STANDARDS.
10. INSTALL 180 FT OF UNDERGROUND CONDUIT IN ACCORDANCE WITH EVERSOURCE STANDARDS & DETAIL 12, (TRENCH "A"), DETAIL 4, SHEET SP-7 FROM TRANSFORMER 2 TO THE END.
11. INSTALL PROPANE GAS DISTRIBUTION STATION.
12. INSTALL UNDERGROUND CONDUIT IN ACCORDANCE WITH EVERSOURCE STANDARDS & DETAIL 12, (TRENCH "A"), DETAIL 4, SHEET SP-7 (ELECTRICAL SERVICE, TYPICAL).

LEGEND

- EXISTING UTILITY POLE
- PROPOSED 2" PLASTIC WATER MAIN
- U-E PROPOSED UNDERGROUND ELECTRICAL, TELEPHONE & CATV.
- PROPOSED DRAIN LINE
- ▨ PROPOSED STONE DRIP EDGE

FOR TOWN APPROVAL PURPOSES:
THE SITE REVIEW REGULATIONS OF THE TOWN OF BARRINGTON ARE A PART OF THIS PLAN. APPROVAL OF THIS PLAN IS CONTINGENT UPON COMPLETION OF ALL REQUIREMENTS OF SAID SITE REVIEW REGULATIONS, EXCEPTING ONLY MODIFICATIONS MADE IN WRITING BY THE BOARD AND ATTACHED HERETO.

RECEIVED

NOV 02 2020

ENGINEERING OFFICE

TRITECH
ENGINEERING CORPORATION

705 CENTRAL AVENUE
COVER NEW HAMPSHIRE 03850
TELEPHONE 603 742 8707
FAX 603 742 8630

REVISIONS	DATE	DESCRIPTION
12-2-19		REVISED PER PLANNING COMMENTS
5-28-20		GENERAL REVISIONS
8-30-20		REVISED PER PEER REVIEW

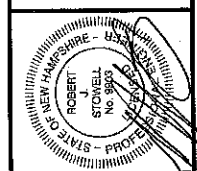

UTILITY PLAN

BARRINGTON STORAGE OFFICE

ROUTE #125
BARRINGTON, NEW HAMPSHIRE

NOVEMBER 11, 2019 JOB No. 19107
SCALE: 1" = 30'

SHEET NO.

SP-3A

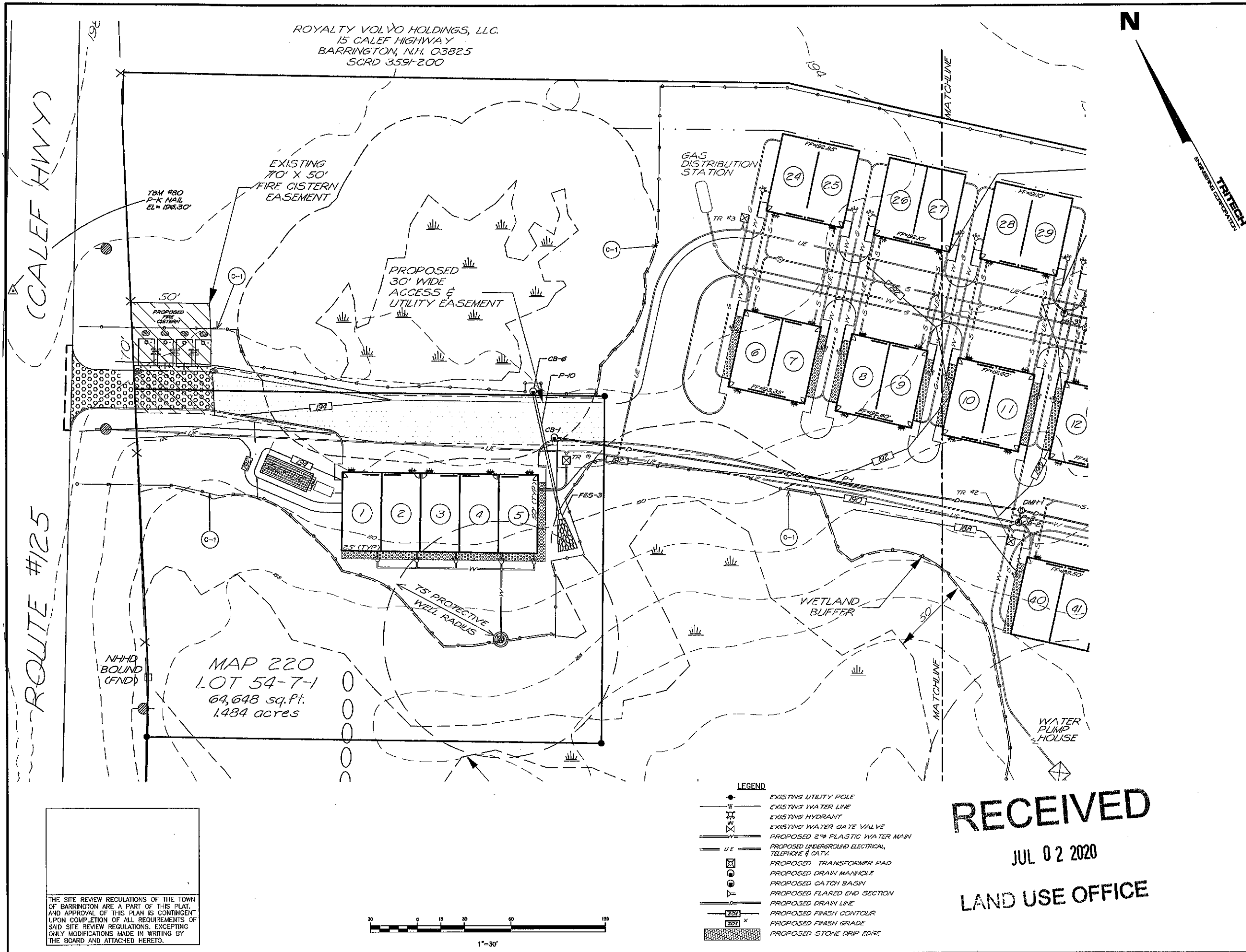

THE SITE REVIEW REGULATIONS OF THE TOWN OF BARRINGTON ARE A PART OF THIS PLAN. APPROVAL OF THIS PLAN IS CONTINGENT UPON COMPLETION OF ALL REQUIREMENTS OF SAID SITE REVIEW REGULATIONS, EXCEPTING ONLY MODIFICATIONS MADE IN WRITING BY THE BOARD AND ATTACHED HERETO.

REVISIONS	DATE	DESCRIPTION
1	12-2-19	1. REVISED PER PLANNING COMMENTS
2	3-28-20	2. GENERAL REVISIONS
3	6-30-20	3. REVISED PER PER REVIEW

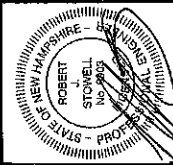

GRADING AND DRAINAGE PLAN
BARRINGTON
STORAGE-OFFICE
ROUTE #125
BARRINGTON, NEW HAMPSHIRE
NOVEMBER 11, 2019 JOB No. 19107
SCALE: 1" = 30'

SHEET NO.

SP-4

TRITECH
ENGINEERING CORPORATION

765 CENTRAL AVENUE
DOVER, NEW HAMPSHIRE 03803
TELEPHONE 603 742 8107
FAX 603 742 9630

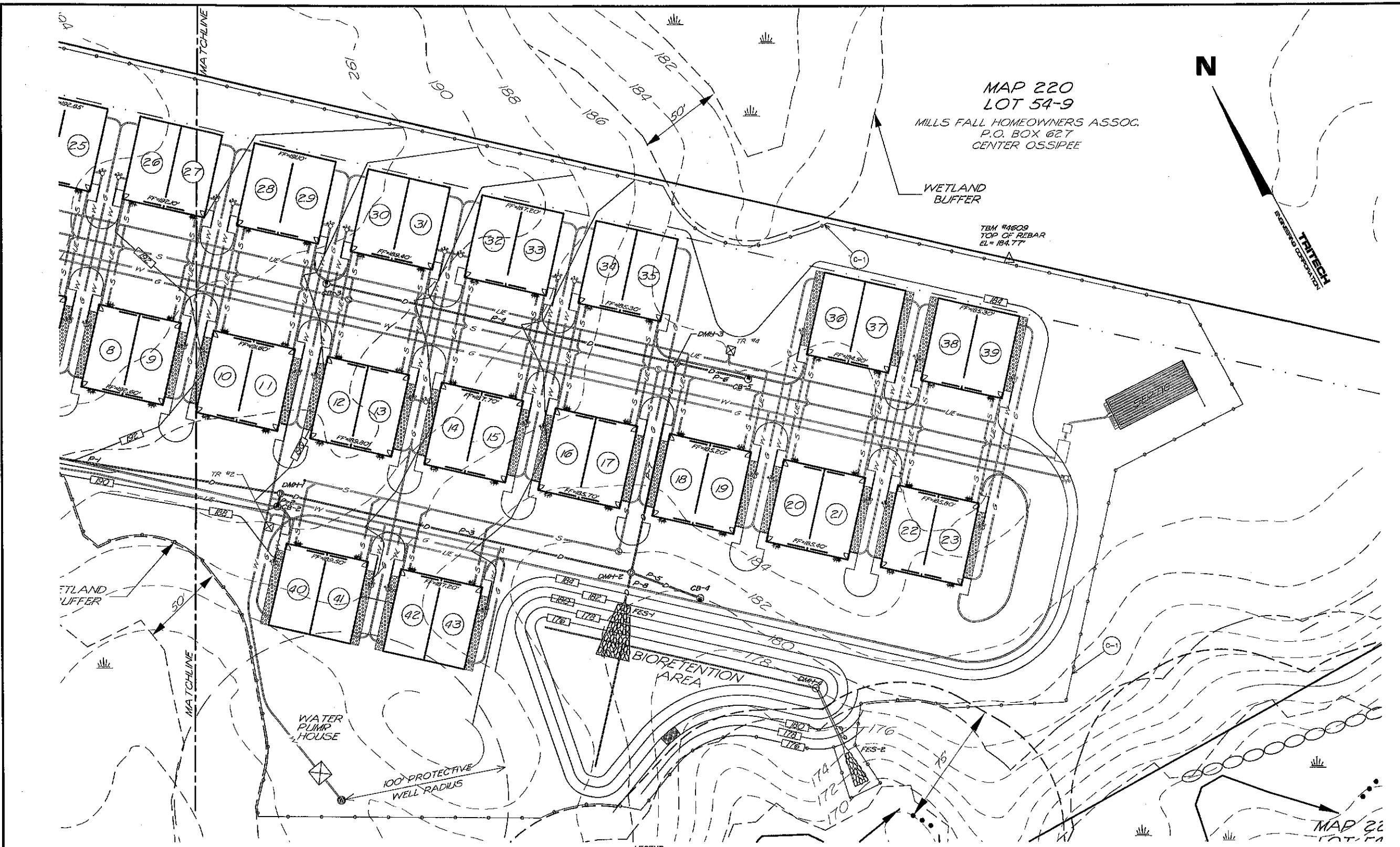

MAP 220
LOT 54-9
MILLS FALL HOMEOWNERS ASSOC.
P.O. BOX 627
CENTER OSSISPEE

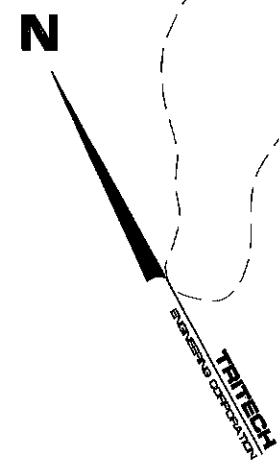

TBM #1809
TOP OF REBAR
EL = 184.77'

WETLAND
BUFFER

WETLAND
BUFFER

WATER
PUMP
HOUSE

100' PROTECTIVE
WELL RADIUS

BIORETENTION
AREA

- LEGEND**
- EXISTING UTILITY POLE
 - EXISTING WATER LINE
 - EXISTING HYDRANT
 - EXISTING WATER GATE VALVE
 - PROPOSED 2" PLASTIC WATER MAIN
 - U.E. PROPOSED UNDERGROUND ELECTRICAL, TELEPHONE & CATV.
 - PROPOSED TRANSFORMER PAD
 - PROPOSED DRAIN MANHOLE
 - PROPOSED CATCH BASIN
 - ▽ PROPOSED FLARED END SECTION
 - PROPOSED DRAIN LINE
 - PROPOSED FINISH CONTOUR
 - PROPOSED FINISH GRADE
 - PROPOSED STONE DRIP EDGE

RECEIVED

JUL 02 2020

LAND USE OFFICE



FOR TOWN APPROVAL PURPOSES:

THE SITE REVIEW REGULATIONS OF THE TOWN OF BARRINGTON ARE A PART OF THIS PLAN, AND APPROVAL OF THIS PLAN IS CONTINGENT UPON COMPLETION OF ALL REQUIREMENTS OF SAID SITE REVIEW REGULATIONS, EXCEPTING ONLY MODIFICATIONS MADE IN WRITING BY THE BOARD AND ATTACHED HERETO.

TRITECH
ENGINEERING CORPORATION

745 CENTRAL AVENUE
DOVER NEW HAMPSHIRE 03830
TELEPHONE 603 742 9707
FAX 603 742 15930

REVISIONS	DATE	DESCRIPTION
1	12-2-19	PREPARED PER PLANNING COMMENTS
2	2-20-20	GENERAL REVISIONS
3	8-30-20	REVISION PER PER REVIEW

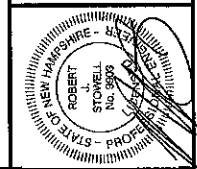

GRADING AND DRAINAGE PLAN
BARRINGTON STORAGE-OFFICE
ROUTE #125
BARRINGTON, NEW HAMPSHIRE
NOVEMBER 11, 2019 JOB No. 19107
SCALE: 1" = 30'

SHEET NO. **SP-4A**

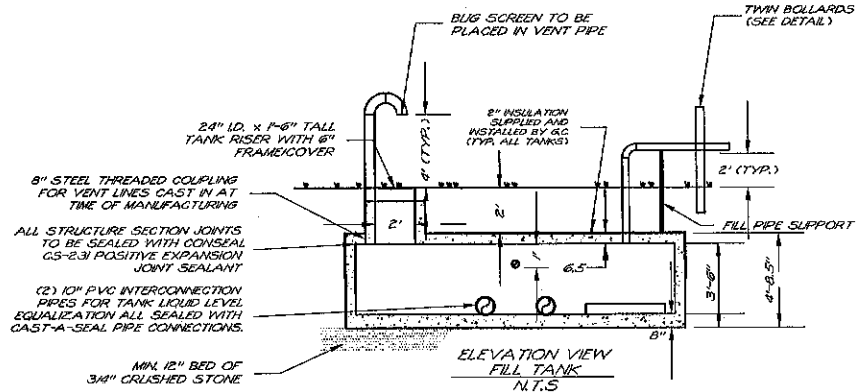
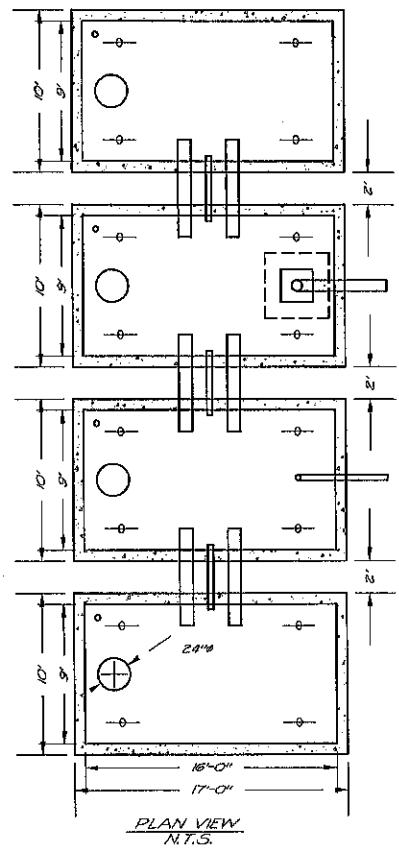

NOTES:

- ONE CUBIC YARD BOULDER SHALL BE PROVIDED AT 8' O.C. AND 5' OFF TANK AFTER FINAL GRADING.
- BACKFILL SHALL BE CLEAN EARTHEN FILL WITH NO STONES LARGER THAN 3" DIA. COMPACT IN PLACE.
- CONTRACTOR SHALL BE RESPONSIBLE FOR ARRANGING THE FINAL INSPECTION WITH THE BARRINGTON FIRE DEPARTMENT.
- ALL STEEL SHALL BE PAINTED.
- ALL PIPES SHALL HAVE A MINIMUM CLEAR DIMENSION OF 24" OFF THE INSIDE WALL OF THE CISTERN.
- THE FIRE CISTERN SHALL BE CONSTRUCTED IN ACCORDANCE WITH NFPA, AND TOWN OF BARRINGTON FIRE DEPARTMENT STANDARDS.
- PRIOR TO CONSTRUCTION, ALL MATERIALS, PIPE, AND FITTINGS SHALL BE SUBMITTED TO THE FIRE CHIEF OF THE TOWN OF BARRINGTON FOR HIS APPROVAL.
- UPON COMPLETION OF CONSTRUCTION, THE FIRE CHIEF OF THE TOWN OF BARRINGTON SHALL BE NOTIFIED FOR FINAL INSPECTION AND ACCEPTANCE.
- FIRE CISTERN SHALL BE WATER TIGHT.
- UPON COMPLETION OF CONSTRUCTION THE FIRE CISTERN SHALL BE FILLED WITH WATER, AND TESTED TO ASSURE THE SYSTEM IS COMPLETELY OPERATIONAL PRIOR TO ACCEPTANCE BY THE TOWN OF BARRINGTON FIRE DEPARTMENT.

1 FIRE CISTERN DETAILS & NOTES
NOT TO SCALE

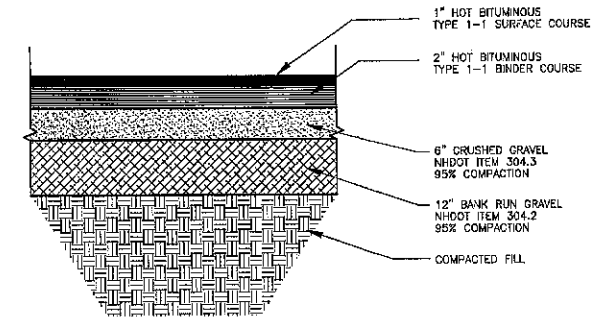

GENERAL MATERIALS NOTES - APPLIES TO ALL DETAILS UNLESS NOTED.

- MATERIALS & CONSTRUCTION METHODS SHALL CONFORM TO THE STATE OF NEW HAMPSHIRE STANDARD SPECIFICATIONS FOR ROAD & BRIDGE CONSTRUCTION.
- COMPACTED FILL UNDER PAVEMENT OR CONCRETE AREAS SHALL BE FREE OF ORGANIC MATERIAL & COMPACTED IN 6" LIFTS TO NOT LESS THAN 95% OPTIMUM DENSITY.
- BANK RUN GRAVEL SHALL BE:

SIEVE	PERCENT PASSING
#4	25 - 70%
#20	< 10%
#40	100%
- CRUSHED GRAVEL SHALL BE:

SIEVE	PERCENT PASSING
#4	95 - 100%
#10	85 - 85%
#20	77 - 50%
#40	0 - 12%
- BASE COURSE OF PAVEMENT SHALL BE 3/4" DIA. TYPE 1-1 HOT BITUMINOUS CONCRETE (125 LBS/SQ.YD.)
- WEARING COURSE OF PAVEMENT SHALL BE 1/2" DIA. TYPE 1-1 HOT BITUMINOUS CONCRETE (115 LBS/SQ.YD.)

3 TYPICAL PAVEMENT SECTION

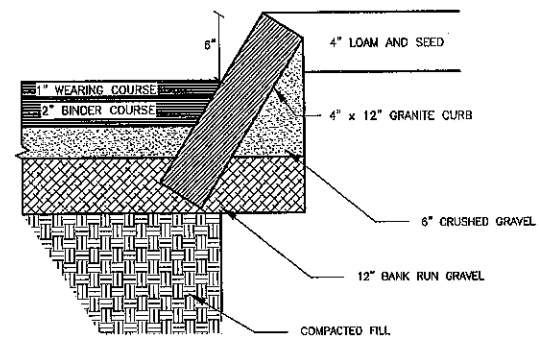

4 SLOPED GRANITE CURB SECTION
NOT TO SCALE

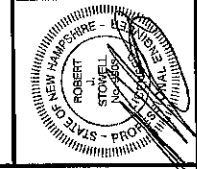
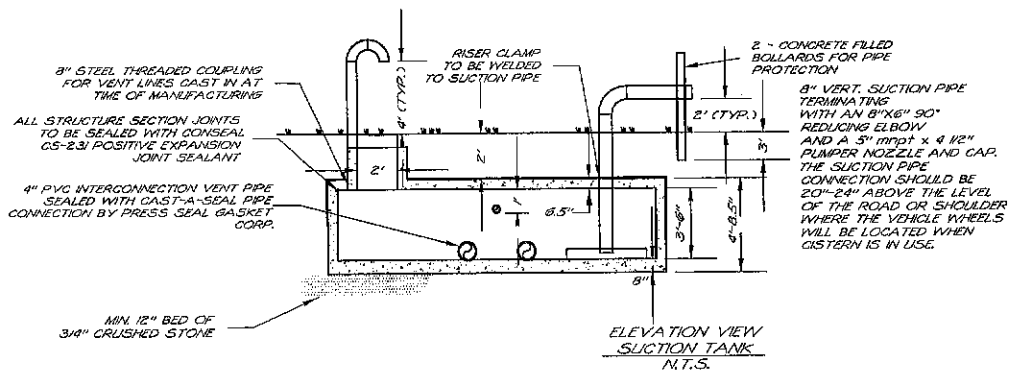

TRITECH
ENGINEERING CORPORATION
765 CENTRAL AVENUE
DOVER, NEW HAMPSHIRE 03820
TELEPHONE 603 742 8107
FAX 603 742 8130

REVISIONS	DATE	DESCRIPTION
1	8-27-20	GENERAL REVISIONS
2	8-30-20	REVISIONS PER PEER REVIEW

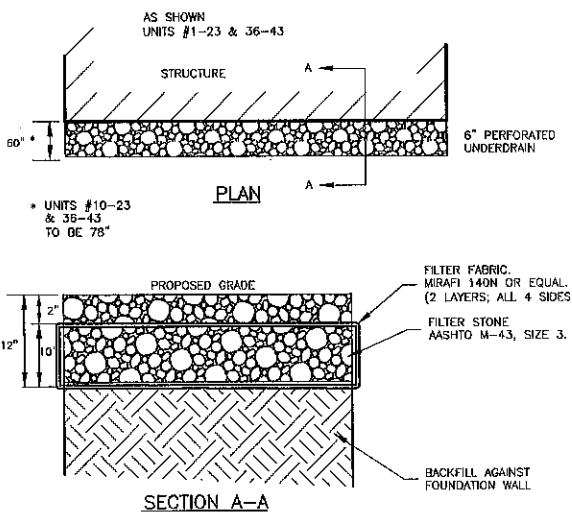

10 BUILDING DRIP EDGE
NOT TO SCALE

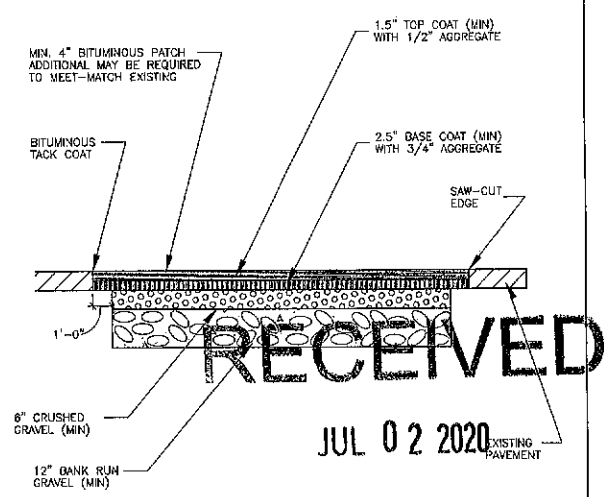

11 PAVEMENT PATCH DETAIL
NOT TO SCALE

12 NOT USED
NOT TO SCALE

CONSTRUCTION DETAILS
BARRINGTON STORAGE-OFFICE
ROUTE #125
BARRINGTON, NEW HAMPSHIRE
NOVEMBER 11, 2019
JOB NO. 19107

SHEET NO. **SP-5**

9 NOT USED
NOT TO SCALE

RECEIVED
JUL 02 2020
LAND USE OFFICE

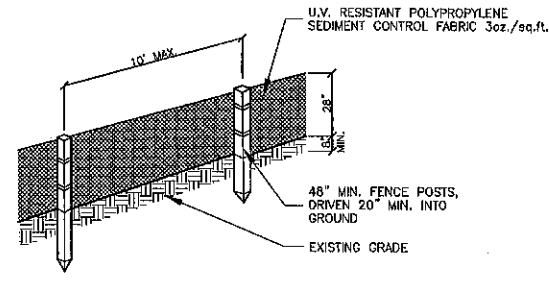

PERSPECTIVE VIEW

NOTES

1. THE GEOTEXTILE FABRIC SHALL MEET THE DESIGN CRITERIA FOR BEST MANAGEMENT PRACTICE FOR SILT FENCES, OF THE "STORMWATER MANAGEMENT AND EROSION AND SEDIMENT CONTROL HANDBOOK FOR URBAN AND DEVELOPING AREAS IN NEW HAMPSHIRE" PREPARED BY ROCKINGHAM COUNTY CONSERVATION DISTRICT, DATED AUGUST 1992.
2. THE FABRIC SHALL BE EMBEDDED A MINIMUM OF 8 INCHES INTO THE GROUND AND THE SOIL COMPACTED OVER THE EMBEDDED FABRIC.
3. WHEN TWO SECTIONS OF FILTER CLOTH ADJOIN EACH OTHER, THEY SHALL BE OVERLAPPED BY 6 INCHES, FOLDED AND STAPLED.
4. FENCE POSTS SHALL BE A MINIMUM OF 36 INCHES LONG AND DRIVEN A MINIMUM OF 20 INCHES INTO THE GROUND. WOOD POSTS SHALL BE OF SOUND QUALITY HARDWOOD AND SHALL HAVE A MINIMUM CROSS SECTIONAL AREA OF 3.0 SQ.IN.
5. MAINTENANCE SHALL BE PERFORMED AS NEEDED TO PREVENT BULGES IN THE SILT FENCE DUE TO DEPOSITION OF SEDIMENT.
6. REMOVE BY HAND AND PROPERLY DISPOSE OF ALL SEDIMENT PRIOR TO REMOVING FENCE.

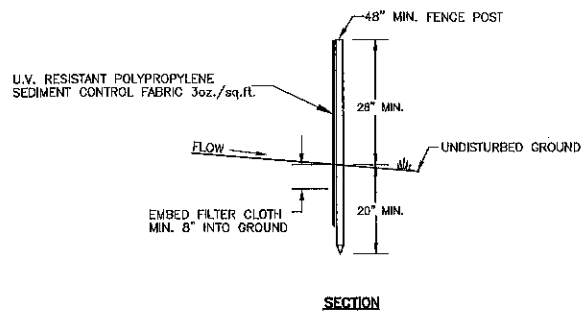

SECTION

1 SILT FENCE
NOT TO SCALE

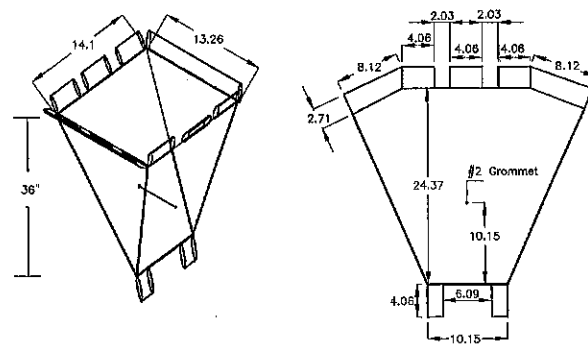

Specifications:

- a) Fabric used should not be laminated.
- b) Silt sack to have two #2 grommets, one on each of the two sides, 15" from the bottom of the silt sack.
- c) The 1/4" wide yellow rope 19" long through the grommets on two sides of the silt sack.

2 Hi Vis Hi Flow Silt Sack
NOT TO SCALE

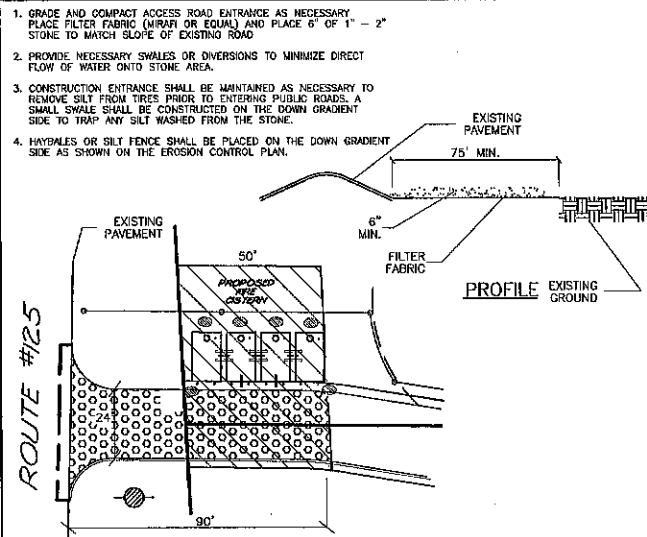

PLAN VIEW

5 STABILIZED CONSTRUCTION ENTRANCE
NOT TO SCALE

1. GRADE AND COMPACT ACCESS ROAD ENTRANCE AS NECESSARY. PLACE FILTER FABRIC (HAY OR EQUAL) AND PLACE 6" OF 1" - 2" STONE TO MATCH SLOPE OF EXISTING ROAD.
2. PROVIDE NECESSARY SWALES OR DIVERSIONS TO MINIMIZE DIRECT FLOW OF WATER ONTO STONE AREA.
3. CONSTRUCTION ENTRANCE SHALL BE MAINTAINED AS NECESSARY TO REMOVE SILT FROM TIRES PRIOR TO ENTERING PUBLIC ROADS. A SMALL SWALE SHALL BE CONSTRUCTED ON THE DOWN GRADIENT SIDE TO TRAP ANY SILT WASHED FROM THE STONE.
4. HAYPLES OR SILT FENCE SHALL BE PLACED ON THE DOWN GRADIENT SIDE AS SHOWN ON THE EROSION CONTROL PLAN.

3 NOT USED
NOT TO SCALE

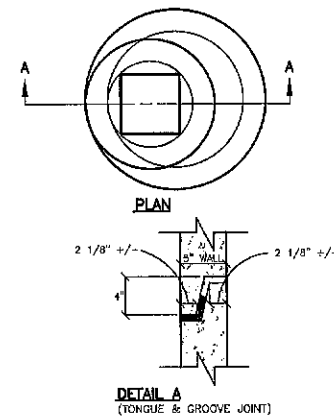

DETAIL A
(TONGUE & GROOVE JOINT)

NOTES

1. ALL SECTIONS SHALL BE CONCRETE CLASS AA(4000 psi).
2. CIRCUMFERENTIAL REINFORCEMENT SHALL BE 0.12 SQ.IN. PER LINEAR FOOT IN ALL SECTIONS AND SHALL BE PLACED IN THE CENTER THIRD OF THE WALL.
3. THE TONGUE OR GROOVE OF THE JOINT SHALL CONTAIN ONE LINE OF CIRCUMFERENTIAL REINFORCEMENT EQUAL TO 0.12 SQ. IN. PER LINEAR FOOT.
4. RISERS OF 1', 2', 3' & 4' CAN BE USED TO REACH DESIRED DEPTH.
5. THE STRUCTURES SHALL BE DESIGNED FOR H-20 LOADING.
6. FOR SHALLOW INVERTS, A FLAT TOP SLAB WITH TONGUE AND GROOVE JOINTS (DETAIL A), MEETING H-20 LOADING MAY BE USED.

6 DEEP SUMP HOODED CATCH BASIN
NOT TO SCALE

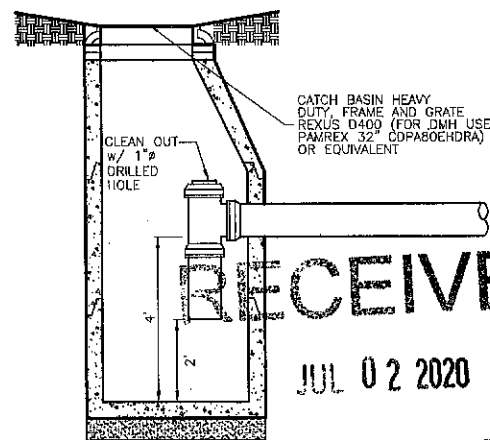

RECEIVED
JUL 02 2020
LAND USE OFFICE

1. THE PROJECT SHALL BE MANAGED TO MEET THE REQUIREMENTS AND INTENT OF RSA 430:53 AND AGR 3800 RELATIVE TO INVASIVE SPECIES.

2. FUGITIVE DUST SHALL BE CONTROLLED IN ACCORDANCE WITH ENH-A 1000.

CRITICAL AREAS
Anywhere on the site that existing vegetation is to be removed will require immediate erosion control treatment. Special care should be taken where runoff enters wetlands. All storm water practices areas shall be stabilized prior to directing storm water to them; specifically all bioretention basins and all infiltration practices.

EROSION AND SEDIMENT CONTROL PRACTICES

Erosion and sediment control practices will include the use of rip-rap, and silt fence check dams. All erosion and sediment control practices will be constructed and maintained according to the minimum standards and specifications contained in the "New Hampshire Stormwater Manual, Volume 2".

A. Erosion and Sediment Control Measures

1. The erosion control procedures shall conform to Section 645 of the "Standard Specifications for Road and Bridge Construction" of the NH DOT, and the "New Hampshire Stormwater Manual."
2. During Construction and thereafter, erosion control measures are to be implemented as noted. The smallest practical area of land should be exposed at any one time during development. The amount of exposed areas which are temporarily stabilized without permanent stabilization shall be limited to 5 acres.
3. During grading operations, install stone check dams at 50 foot intervals in drainage swales and at drain inlets where shown. Barriers are to be maintained and cleaned until disturbed areas are stabilized.
4. Any disturbed areas which are to be left temporarily, and which will be regraded later during construction shall be machine hay mulched and seeded with rye grass to prevent erosion.
5. Silt fences and other erosion control measures shall be inspected weekly and after every 0.25" rainfall event during the life of the project. All damaged silt fences shall be repaired. Sediment deposits shall periodically be removed.
6. Avoid the use of future open spaces (loam and seed areas) wherever possible during the construction. Construction traffic shall use the roadbeds of future roads and parking areas.
7. Topsoil required for the establishment of vegetation shall be stock piled in amounts necessary to complete finished grading of all exposed areas.
8. Areas to be filled shall be cleared, grubbed, and stripped of topsoil to remove trees, vegetation, roots or other objectionable material. Stumps shall be disposed by grinding or fill in an approved facility.
9. All fills shall be placed and compacted to reduce erosion, slippage settlement, subsidence or other related problems.
10. All fill shall be placed and compacted in layers not to exceed 8 inches in thickness.
11. Frozen material or soft, mucky or highly compressible material shall not be incorporated into fills.
12. Fill material shall not be placed on a frozen foundation subgrade.
13. Disturbed areas shall be seeded immediately following finished grading.
14. Limit of exposed area that is temporarily stabilized without permanent stabilization is 5 acres or less.
15. All areas not stabilized by Nov. 1st must be protected by Erosion Control Blankets or equivalent and mulched/seeded with winter rye or oats.
16. All disturbed areas must be seed and mulched within 3 days of final grading, permanently stabilized within 15 days of final grading or temporarily stabilized within 45 days of initial disturbance.
17. All ditched or swales are to be stabilized prior to directing runoff to these features.
18. All cut and fill slopes shall be seeded immediately.
19. An area shall be considered stable if one of the following has occurred:
 - a.) Base course gravels are installed in areas to be paved
 - b.) A minimum of 85% vegetated growth has been established
 - c.) A minimum of 3" of non-erosive material such as stone or riprap has been installed
 - d.) Erosion control blankets have been properly installed.

B. Vegetative Practice
All ground areas opened up for construction will be regraded, loamed, seeded and mulched in the shortest practical time. All Temporary and Permanent Seeding must be applied prior to October 1st. Employ temporary erosion and sedimentation control devices as detailed in this plan as necessary until adequate stabilization has been assured.

A. Temporary Seeding & Hay Mulching

1. At no time shall any disturbed area remain unstabilized for longer than 30 days. All areas where construction is not completed within 30 days of the initial disturbance shall receive temporary seeding measures.
2. Fertilizer shall be spread on the top layer of loam and worked into the surface. Fertilizer application rate shall be 300 pounds per acre of 10-10-10 fertilizer.
3. Seed shall be Winter rye, 112 LBS. per acre.
4. Remove stones and trash that will interfere with seeding the area. Where feasible, till the soil to a depth of about 3 inches to prepare a seedbed and mix fertilizer into the soil. The seedbed should be left in a firm and smooth condition. The last tillage operation should be performed across the slope whenever practical.
5. If seeding between May 15th and August 15th, hay mulch shall be applied immediately after seeding at a rate of 1.5 to 2 tons per acre and shall be held in place using appropriate techniques from the Erosion and Sediment Control Handbook.
6. The surface shall be watered and kept moist with a fine spray as required without washing away the soil, until the grass is well established. Any areas which are not satisfactorily covered with grass shall be reseeded, and all noxious weeds are removed.

B. Permanent Seeding & Hay Mulching

1. All disturbed areas shall be loamed (4") and limed. Lime shall be thoroughly incorporated into the loam layer at a rate of 2 tons per acre.
2. Fertilizer shall be spread on the top layer of loam and worked into the surface. Fertilizer application rate shall be 500 pounds per acre of 10-20-20 fertilizer.
3. Seed shall be 48 lbs. per acre, SCS mixture "c" (20 lbs. tall fescue, 20 lbs. creeping red fescue and 8 lbs. birds foot trefoil = 48 lbs. total.) The soil shall be lightly raked immediately before seeding. One half the seed shall be sown in one direction and the other half at right angles to the original direction. It shall be lightly raked in to the soil to a depth not over 1/4 inch and rolled with hand roller weighing not over 100 pounds per linear foot to width.
4. Hay mulch shall be applied immediately after seeding at a rate of 1.5 to 2 tons per acre and shall be held in place using appropriate techniques from the Erosion and Sediment Control Handbook. The surface shall be watered and kept moist with a fine spray as required, without washing away the soil, until the grass is well established. Any areas which are not satisfactorily covered with grass shall be reseeded, and all noxious weeds removed.

CONSTRUCTION SEQUENCE

1. Do not begin construction until all local, state and federal permits have been applied for and received.
2. Install silt fences filter sack as necessary to control erosion and prevent sediment contamination prior to any earth moving activities.
3. Cut and remove trees, shrubs, saplings, brush, vines and other debris and rubbish as specified for construction.
4. Care shall be taken to preserve the infiltration capacity of the infiltrating soil. See the New Hampshire Stormwater Manual for additional information.
5. Construct stormwater Bio #1. Do not direct runoff to these practices until the practice and contributing areas are fully stabilized.
6. Building construction may begin.
7. Construct driveways, parking and utilities.
8. Loam and seed disturbed areas in accordance with vegetative practice and general construction notes. Cut and fill slopes shall be seeded immediately after their construction.
9. All areas receiving runoff, including but not limited to the stormwater infiltration shall be stabilized prior to directing runoff to them.
10. All soils that are finish graded must be stabilized within 72 hours of disturbance.
11. Maintain disturbed areas as necessary.

MAINTENANCE

- During the period of construction and/or until long term vegetation is established:
1. Seeded areas will be fertilized and reseeded as necessary to insure vegetative establishment.
 2. The side slopes will be checked after each significant rainfall.
 3. The side slopes will be checked weekly and repaired when necessary until adequate vegetation is established.
 4. The silt fence barriers will be checked regularly. Necessary repairs will be made to correct undermining or deterioration of the structures.

WINTER CONSTRUCTION NOTES

1. All proposed vegetated areas which do not exhibit a minimum of 85% vegetation growth by October 15th, or which are disturbed after October 15th, shall be stabilized by seeding and installing erosion control blankets on slopes greater than 3:1, and seeding and placing 3 to 4 tons of mulch per acre, secured with anchored netting, elsewhere. The installation of erosion control blankets or mulch and netting shall not occur over accumulated snow or on frozen ground and shall be completed in advance of thaw or spring melts.
2. All ditches or swales which do not exhibit a minimum of 85% vegetation growth by October 15th, or which are disturbed after October 15th, shall be stabilized temporarily with stone or erosion control blankets appropriate for the design flow conditions.
3. After November 15th, incomplete road or parking surfaces, where work has stopped for the winter season, shall be protected with a minimum of 3 inches of crushed gravel per NHDOT Item 304.3.

12 EROSION AND SEDIMENT CONTROL NOTES

TRITECH
ENGINEERING CORPORATION

705 CENTRAL AVENUE
DOVER NEW HAMPSHIRE 03820
TELEPHONE 603 742 8707
FAX 603 742 9950

REVISIONS	DATE	DESCRIPTION

STATE OF NEW HAMPSHIRE
ROBERT J. STOWELL
REGISTERED PROFESSIONAL ENGINEER
NO. 10000

CONSTRUCTION DETAILS
BARRINGTON
STORAGE-OFFICE
ROUTE #125
BARRINGTON, NEW HAMPSHIRE

NOVEMBER 11, 2019
JOB No. 19107

SHEET NO.

SP-6

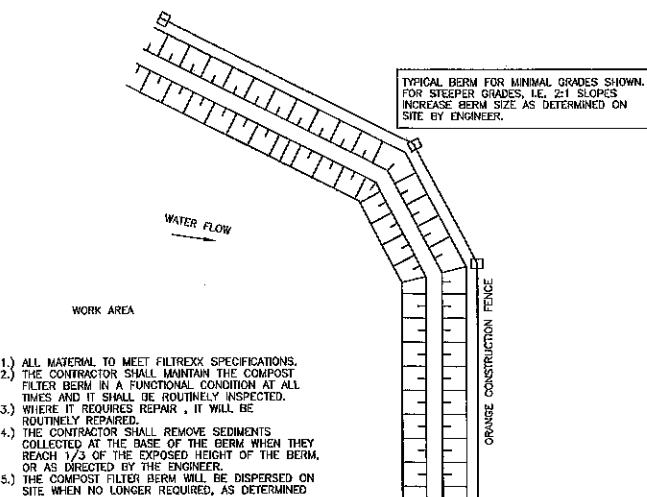

TYPICAL BERM FOR MINIMAL GRADES SHOWN FOR STEEPER GRADES, I.E. 2:1 SLOPES INCREASE BERM SIZE AS DETERMINED ON SITE BY ENGINEER.

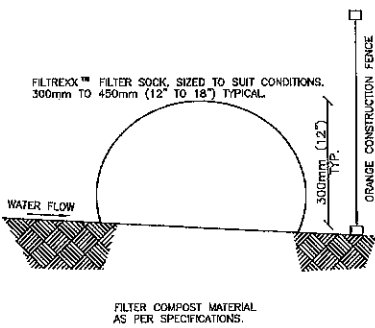

7 FILTERREXX SOCK - SILT FENCE
NOT TO SCALE

- 1) ALL MATERIAL TO MEET FILTERREXX SPECIFICATIONS.
- 2) THE CONTRACTOR SHALL MAINTAIN THE COMPOST FILTER BERM IN A FUNCTIONAL CONDITION AT ALL TIMES AND IT SHALL BE ROUTINELY INSPECTED.
- 3) WHERE IT REQUIRES REPAIR, IT WILL BE ROUTINELY REPAIRED.
- 4) THE CONTRACTOR SHALL REMOVE SEDIMENTS COLLECTED AT THE BASE OF THE BERM WHEN THEY REACH 1/3 OF THE EXPOSED HEIGHT OF THE BERM, OR AS DIRECTED BY THE ENGINEER.
- 5) THE COMPOST FILTER BERM WILL BE DISPERSED ON SITE WHEN NO LONGER REQUIRED, AS DETERMINED BY THE ENGINEER.

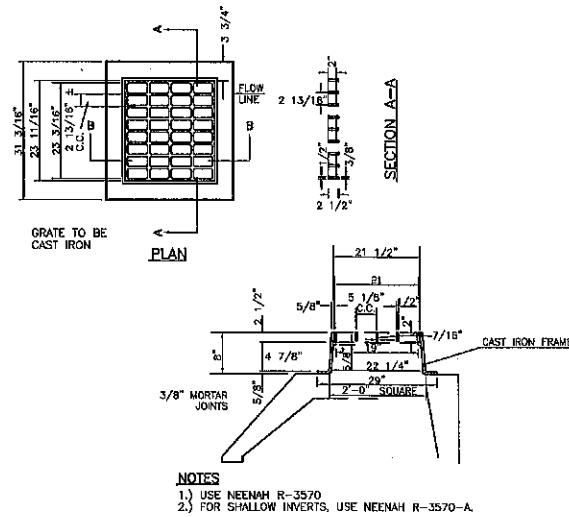

① CATCH BASIN FRAME & GRATE
NOT TO SCALE

② NOT USED
NOT TO SCALE

③ NOT USED
NOT TO SCALE

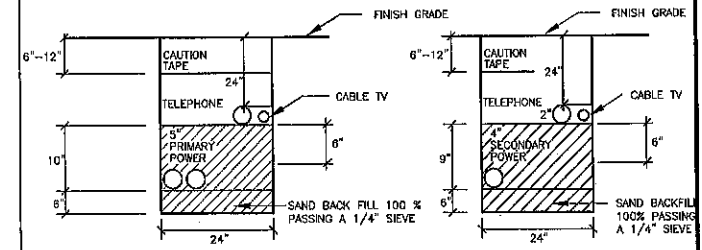

ELECTRICAL TRENCH "A"
NOT TO SCALE

ELECTRICAL TRENCH "B"
NOT TO SCALE

- 1.) TELEPHONE CONDUIT SHALL BE 3" SCHEDULE 40 PVC, WITH STEEL SWEEPS AT RISER POLE, 90° BENDS AND AT BUILDING.
- 2.) LEAVE PULL ROPE IN ALL CONDUITS FOR CABLE INSTALLATION.
- 3.) FOR COMPLETE SPECIFICATION SEE "PUBLIC SERVICE COMPANY OF NEW HAMPSHIRE CONSTRUCTION SPECIFICATIONS FOR UNDERGROUND CONDUIT SYSTEMS".
- 4.) CONTRACTOR SHOULD VERIFY THE NUMBER & SIZE OF CONDUIT WITH THE APPROPRIATE UTILITIES.

④ ELECTRICAL TRENCH
NOT TO SCALE

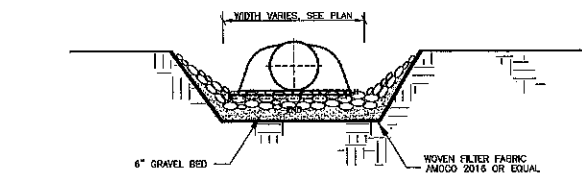
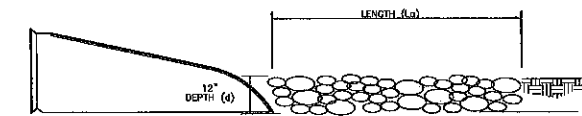
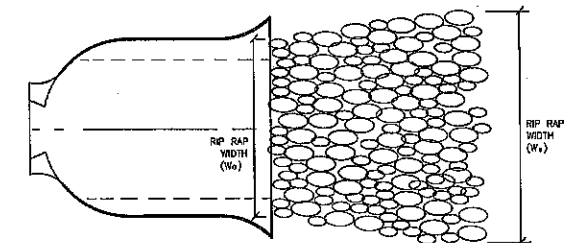

⑧ RIPRAP DETAIL
NOT TO SCALE

⑤ NOT USED
NOT TO SCALE

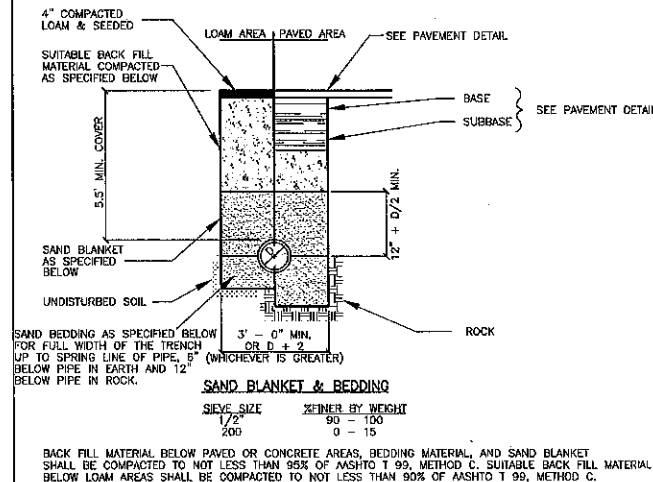

⑥ WATER LINE TRENCH
NOT TO SCALE

⑦ NOT USED
NOT TO SCALE

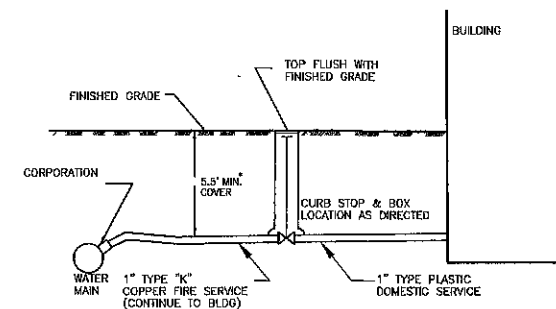

- NOTES:
- 1.) SERVICE TO BE TYPE "K" COPPER OR EQUAL, APPROVED BY LOCAL AND STATE SPECIFICATIONS.
 - 2.) BALL VALVE CURB STOP COMPRESSION (NO DRAIN)
 - 3.) WATER SERVICE SIZE MAY BE MODIFIED AS WARRANTED BY FIRE SUPPRESSION SYSTEM DESIGN.

⑨ BUILDING WATER SERVICE

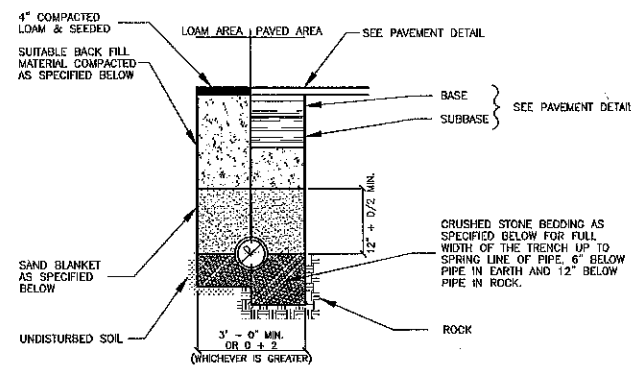

⑩ STORM DRAINAGE & SEWER PIPE TRENCH
NOT TO SCALE

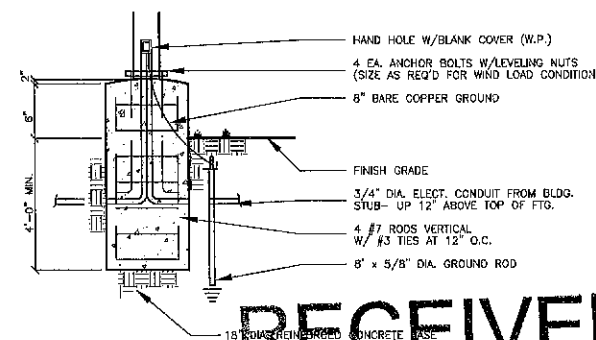

⑪ SITE LIGHTING BASE
NOT TO SCALE

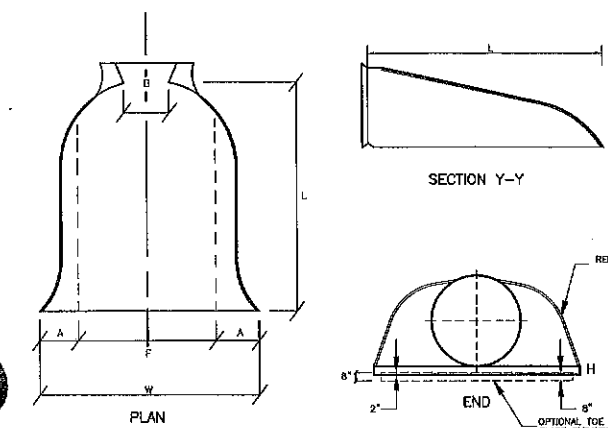

⑫ CMP FLARED END SECTION
NOT TO SCALE

TRITECH
ENGINEERING CORPORATION

786 CENTRAL AVENUE
DERRY, NEW HAMPSHIRE 03880
TELEPHONE 603 742 8707
FAX 603 742 8600

REVISIONS	DATE	DESCRIPTION
	6-30-20	REVISED PER PEER REVIEW

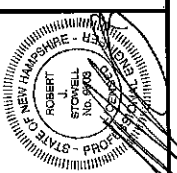

CONSTRUCTION DETAILS
BARRINGTON STORAGE-OFFICE
ROUTE #125
BARRINGTON, NEW HAMPSHIRE
NOVEMBER 11, 2019 JOB No. 19107

SHEET NO.

SP-7

RECEIVED

JUL 02 2020

LAND USE OFFICE

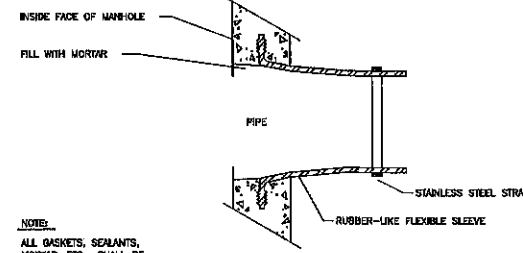
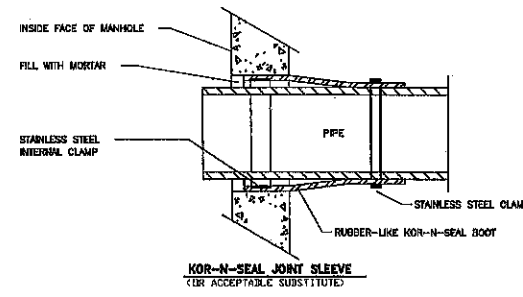
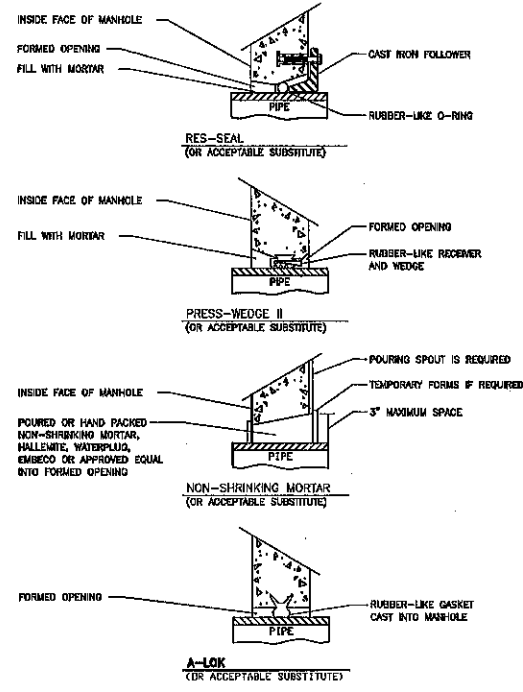

NOTE:
ALL GASKETS, SEALANTS, MORTAR, ETC., SHALL BE INSTALLED IN ACCORDANCE WITH MANUFACTURERS' WRITTEN INSTRUCTIONS

DETAIL "A" - PIPE TO MANHOLE JOINTS

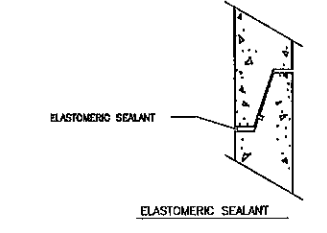

NOTE:
ALL GASKETS AND SEALANTS SHALL BE INSTALLED IN ACCORDANCE WITH MANUFACTURERS' WRITTEN INSTRUCTIONS

DETAIL "B" - HORIZONTAL JOINTS

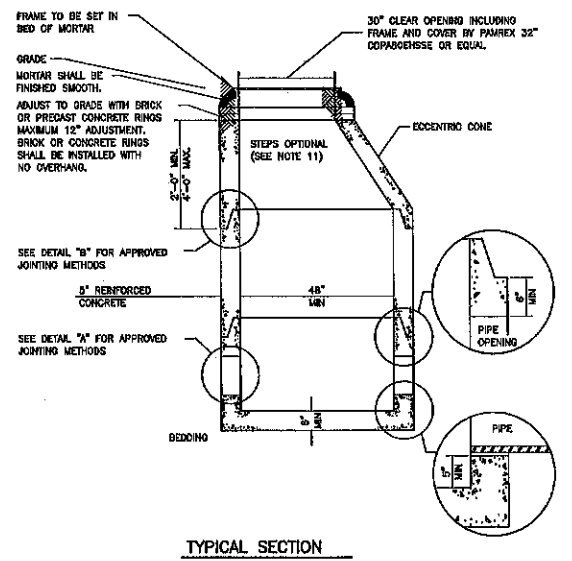

TYPICAL SECTION

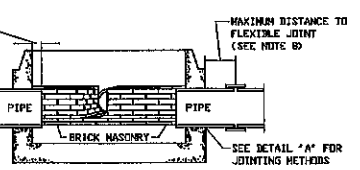
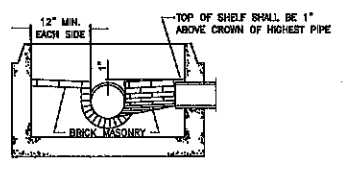

NOTES:
A) INVERT AND SHELF TO BE PLACED AFTER LEAKAGE TEST
B) CARE SHALL BE TAKEN TO INSURE THAT THE BRICK INVERT IS A SMOOTH CONTINUATION OF THE SEWER INVERT. INVERT BRICKS SHALL BE LAID ON EDGE.
C) BASE SECTION TO BE FULL WALL THICKNESS AND MONOLITHIC TO A POINT 6" ABOVE THE PIPE CROWN

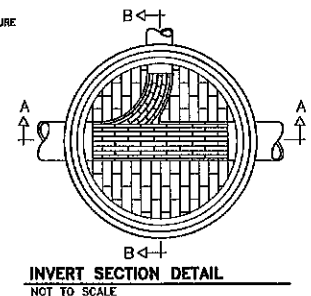

INVERT SECTION DETAIL
NOT TO SCALE

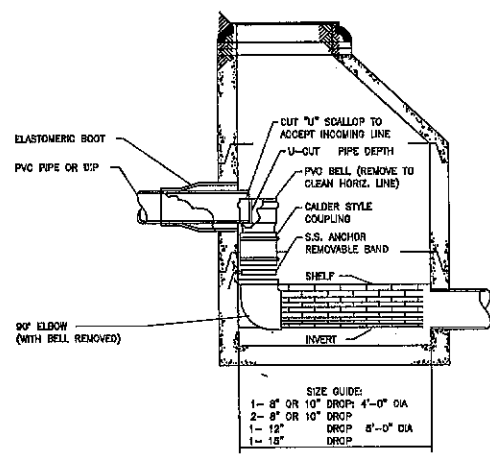

DROP INLET
NOT TO SCALE

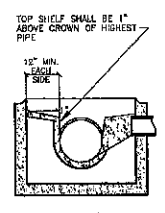
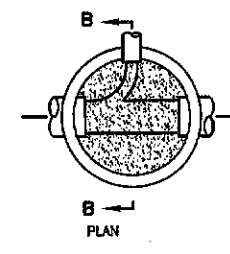

SECTION B-B

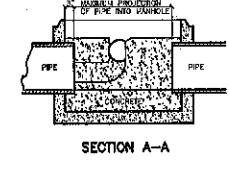

SECTION A-A

NOTE:
CARE SHALL BE TAKEN TO INSURE THAT THE CONCRETE INVERT IS A SMOOTH CONTINUATION OF THE DRAIN INVERT.
BASE SECTION TO BE FULL WALL THICKNESS AND MONOLITHIC TO A POINT 6" ABOVE THE PIPE CROWN.

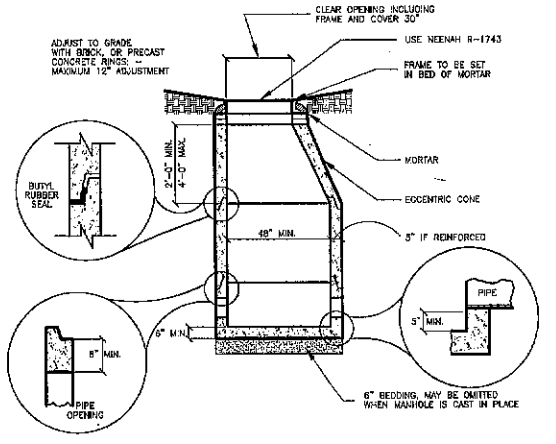

1 DRAIN MANHOLE DETAILS
NOT TO SCALE

GENERAL NOTES

- IT IS THE INTENTION THAT THE MANHOLE, INCLUDING ALL COMPONENT PARTS, HAVE ADEQUATE SPACE, STRENGTH AND LEAK PROOF QUALITIES CONSIDERED NECESSARY FOR THE INTENDED SERVICE. SPACE REQUIREMENTS AND CONFIGURATIONS, SHALL BE AS SHOWN ON THE DRAWING. MANHOLES SHALL BE AN ASSEMBLY OF PRECAST SECTIONS, WITH STEEL REINFORCEMENT, WITH ADEQUATE JOINTING, OR CONCRETE CAST MONOLITHICALLY IN PLACE WITH REINFORCEMENT. IN ANY APPROVED MANHOLE, THE COMPLETE STRUCTURE SHALL BE OF SUCH MATERIAL AND QUALITY AS TO WITHSTAND LOADS OF 8 TONS (4-20 LOADS) WITHOUT FAILURE AND PREVENT LEAKAGE IN EXCESS OF ONE GALLON PER DAY PER VERTICAL FOOT OF MANHOLE, CONTINUOUSLY FOR THE LIFE OF THE STRUCTURE. A PERIOD GENERALLY IN EXCESS OF 25 YEARS IS TO BE UNDERSTOOD IN BOTH CASES.
- BARRELS AND CONE SECTIONS SHALL BE PRECAST REINFORCED CONCRETE, OR POURED IN PLACE REINFORCED CONCRETE.
- PRECAST CONCRETE BARREL SECTIONS, CONES AND BASES SHALL CONFORM TO ASTM C478.
- LEAKAGE TEST SHALL BE PERFORMED IN ACCORDANCE WITH THE SPECIFICATIONS.
- INVERTS AND SHELVES: MANHOLES SHALL HAVE A BRICK PAVED OR PRECAST CONCRETE SHELF AND INVERT, CONSTRUCTED TO CONFORM TO THE SIZE OF THE PIPE AND FLOW. AT CHANGES IN DIRECTIONS, THE INVERTS SHALL BE LAID OUT IN CURVES OF THE LONGEST RADIUS POSSIBLE TANGENT TO THE CENTER LINE OF THE SEWER PIPES. SHELVES SHALL BE CONSTRUCTED TO THE ELEVATION OF THE HIGHEST PIPE CROWN AND SLOPE TO DRAIN TOWARD THE FLOWING THROUGH CHANNEL. UNDERLAYMENT OF INVERT AND SHELF SHALL CONSIST OF BRICK MASONRY OR PRECAST CONCRETE.
- FRAMES AND COVERS: MANHOLE FRAMES AND COVERS SHALL BE OF HEAVY DUTY DESIGN AND PROVIDE A 30-INCH CLEAR OPENING. A 3-INCH (MINIMUM HEIGHT) WORD "SEWER" FOR SEWERS AND "DRAIN" FOR DRAINS SHALL BE PLAINLY CAST INTO THE CENTER OF EACH COVER.
- BEDDING: SCREENED GRAVEL AND/OR CRUSHED STONE FREE FROM CLAY, LOAM, ORGANIC MATTER AND MEETING ASTM C33, SIZE NUMBER 67.
100% PASSING 1 INCH SCREEN 0-10% PASSING #4 SIEVE
90-100% PASSING 1/2 INCH SCREEN 0-5% PASSING #8 SIEVE
20-55% PASSING 1/4 INCH SCREEN
WHERE ORDERED BY THE ENGINEER TO STABILIZE THE BASE, SCREENED GRAVEL OR CRUSHED STONE 1/2 INCH TO 1 INCH SHALL BE USED.
- FLEXIBLE JOINT: A FLEXIBLE JOINT SHALL BE PROVIDED WITHIN THE FOLLOWING DISTANCES: RCP & CI PIPE - ALL SIZES - 48"
- SHALLOW MANHOLE: IN LIEU OF A CONE SECTION, WHEN MANHOLE DEPTH IS LESS THAN 6 FEET, A REINFORCED CONCRETE SLAB COVER MAY BE USED HAVING AN ECCENTRIC ENTRANCE OPENING AND CAPABLE OF SUPPORTING H-20 LOADS.
- MANHOLE STEPS MAY BE PERMITTED UPON REQUEST BY THE OWNER AS SECONDARY ADDITIONAL SAFETY FEATURE SUPPLEMENTARY TO THE PRIMARY PORTABLE LADDER ENTRY AND WHEN INSTALLED UNDER THE FOLLOWING CONDITIONS:
 - THE STEPS SHALL BE MANUFACTURED OF PLASTIC COVERED STEEL. THEY SHALL BE SHAPED SO THEY CANNOT BE PULLED OUT OF THE CONCRETE WALL IN WHICH THEY ARE EMBEDDED.
 - THE STEPS SHALL BE EMBEDDED IN THE CONCRETE BY THE MANUFACTURER DURING MANUFACTURE OR IMMEDIATELY FOLLOWING REMOVAL OF FORMS. SECURING THE STEPS WITH MORTAR IN DRILLED OR CAST HOLES, WILL NOT BE ACCEPTABLE.
 - THE STEPS SHALL BE OF THE DROP TYPE WITH A DEPRESSED SECTION FOR HANDHOLD. APPROXIMATELY 14"x10" IN DIMENSION.
- HORIZONTAL JOINTS BETWEEN SECTIONS OF PRECAST CONCRETE BARRELS SHALL BE OF A TYPE APPROVED BY THE ENGINEER, WHICH TYPE SHALL, IN GENERAL, DEPEND FOR WATERTIGHTNESS UPON AN ELASTOMERIC OR MASTIC-LIKE GASKET. APPROVED ELASTOMERIC SEALANTS ARE: RAM-NEX KENT SEAL NO.2 EZ
- PIPE TO MANHOLE JOINTS SHALL BE ONLY AS APPROVED BY THE ENGINEER AND IN GENERAL, WILL DEPEND FOR WATERTIGHTNESS UPON EITHER AN APPROVED NON-SHRINKING MORTAR OR ELASTOMERIC SEALANT.

TRITECH
ENGINEERING CORPORATION

785 CENTRAL AVENUE
COVER NEW HAMPSHIRE 03880
TELEPHONE 603 742 8107
FAX 603 742 8830

REVISIONS	DATE:	DESCRIPTION:

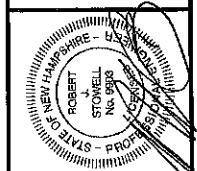

SEWER DETAILS
BARRINGTON STORAGE-OFFICE
ROUTE #125
BARRINGTON, NEW HAMPSHIRE
NOVEMBER 11, 2019 JOB No. 19107

RECEIVED
JUL 02 2020
LAND USE OFFICE

SHEET NO. **SP-8**

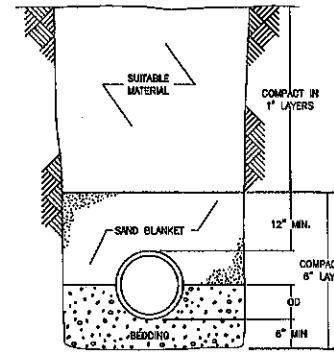

TRENCH CROSS-SECTION
NOT TO SCALE

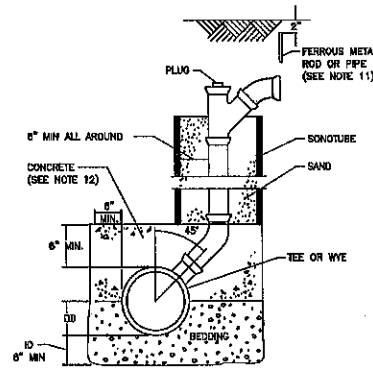

CHIMNEY (SEE NOTE 13)
NOT TO SCALE

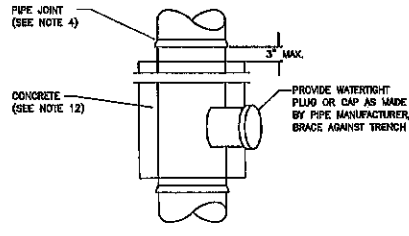

PLAN

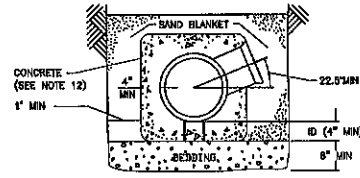

SECTION

CONCRETE FULL ENCASEMENT
NOT TO SCALE

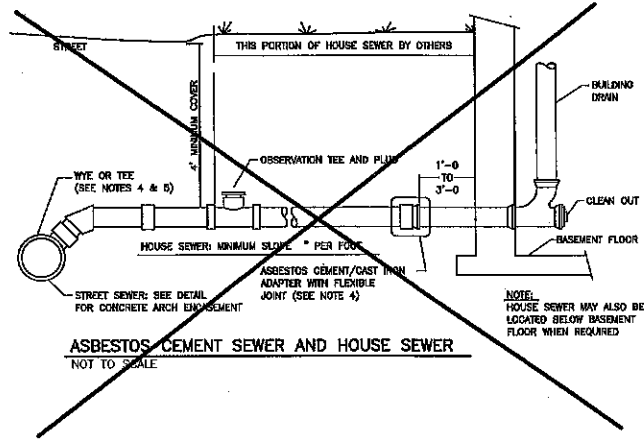

ASBESTOS CEMENT SEWER AND HOUSE SEWER
NOT TO SCALE

NOT USED

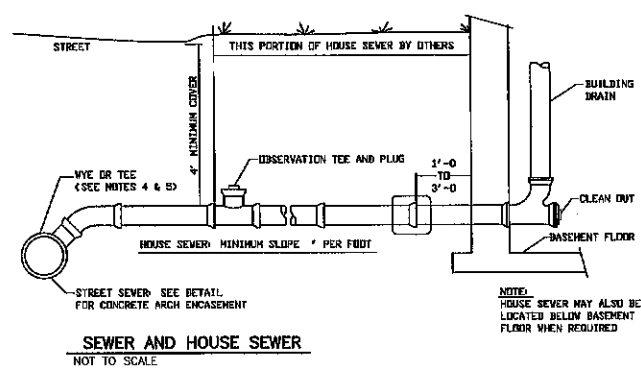

SEWER AND HOUSE SEWER
NOT TO SCALE

GENERAL NOTES

- 1) MINIMUM SIZE PIPE FOR HOUSE SERVICE SHALL BE FOUR INCHES.
- 2) PIPE AND JOINT MATERIALS:

A. PLASTIC SEWER PIPE

- 1. PIPE AND FITTINGS SHALL CONFORM TO THE FOLLOWING ASTM STANDARDS:

ASTM STANDARDS	GENERIC PIPE MATERIAL	SIZES APPROVED
D3034	*PVC (SOLID WALL)	8" THROUGH 15" (SDR 35)
F79	PVC (SOLID WALL)	18" THROUGH 27" (T-1 & T-2)
F789	PVC (SOLID WALL)	4" THROUGH 18" (T-1 TO T-3)
F794	PVC (RIBBED WALL)	8" THROUGH 18"
D2680	*ABS (COMPOSITES WALL)	8" THROUGH 15"

*PVC: POLY VINYL CHLORIDE
*ABS: ACRYLONITRILE-BUTADIENE-STYRENE

- 2. JOINTS SEALS FOR PVC PIPE SHALL BE OIL RESISTANT COMPRESSION RINGS OF ELASTOMERIC MATERIAL CONFORMING TO ASTM D-3212 AND SHALL BE PUSH-ON, BELL AND SPIGOT TYPE.

ABS TRUSS PIPE AND FITTINGS SHALL CONFORM TO ASTM D-2680, POLYMER COMPOUNDING SHALL BE TO ASTM D-1788 (CLASS 322).
JOINTS FOR ABS TRUSS PIPE SHALL BE CHEMICAL WELDED COUPLINGS TYPE SC IN ACCORDANCE WITH ASTM D-2680, FORMING A CHEMICAL WELDED JOINT.

B. DUCTILE-IRON PIPE, FITTINGS AND JOINTS.

- 1. DUCTILE IRON PIPE AND FITTINGS SHALL CONFORM TO THE FOLLOWING STANDARDS OF THE UNITED STATES OF AMERICA STANDARDS INSTITUTE: A21.50 THICKNESS DESIGN OF DUCTILE IRON PIPE AND WITH ASTM A-536 DUCTILE IRON CASTINGS. A21.51 DUCTILE IRON PIPE, CENTRIFUGALLY CAST IN METAL MOLDS OR SAND-LINED MOLDS FOR WATER OR OTHER LIQUIDS.
- 2. JOINTS SHALL BE OF THE MECHANICAL OR PUSH-ON TYPE. JOINTS AND GASKETS SHALL CONFORM TO: A21.11 RUBBER GASKETS JOINTS FOR CAST IRON PRESSURE PIPE & FITTINGS

- 3) DAMAGED PIPE SHALL BE REJECTED AND REMOVED FROM THE JOB SITE.
- 4) JOINTS SHALL BE DEPENDENT UPON A NEOPRENE OR ELASTOMERIC GASKET FOR WATER-TIGHTNESS. ALL JOINTS SHALL BE PROPERLY MATCHED WITH THE PIPE MATERIALS USED. WHERE DIFFERING MATERIALS ARE TO BE CONNECTED, AS AT THE STREET SEWER WYE OR AT THE FOUNDATION WALL, APPROPRIATE MANUFACTURED ADAPTERS SHALL BE USED.
- 5) TEES AND WYES: WHERE A TEE OR WYE IS NOT AVAILABLE IN THE EXISTING STREET SEWER, AN APPROPRIATE CONNECTION SHALL BE MADE, FOLLOWING MANUFACTURERS' INSTRUCTIONS USING A BOLTED, CLAMPED OR EPOXY-CEMENTED SADDLE TAPPED INTO A SMOOTHLY DRILLED OR SAWN OPENING IN THE SEWER. THE PRACTICE OF BREAKING AN OPENING WITH A SLEDGE HAMMER, STUFFING CLOTH OR OTHER SUCH MATERIAL AROUND THE JOINT, OR APPLYING MORTAR TO HOLD THE CONNECTION, AND ANY OTHER SIMILAR CRUDE PRACTICES OR INEPT OR HASTY IMPROVISATIONS WILL NOT BE PERMITTED. THE CONNECTION SHALL BE CONCRETE ENCASED AS SHOWN IN THE DETAIL UP TO AND INCLUDING 15" DIAMETER.
- 6) HOUSE SEWER INSTALLATION: THE PIPE SHALL BE HANDLED, PLACED AND JOINTED IN ACCORDANCE WITH INSTALLATION GUIDES OF THE APPROPRIATE MANUFACTURER. IT SHALL BE CAREFULLY BEDDED ON A 4" LAYER OF CRUSHED STONE AND/OR GRAVEL AS SPECIFIED IN NOTE 10. BEDDING AND RE-FILL FOR DEPTH OF 12" INCHES ABOVE THE TOP OF THE PIPE SHALL BE CAREFULLY AND THOROUGHLY TAMPED BY HAND OR WITH APPROPRIATE MECHANICAL DEVICES.

THE PIPE SHALL BE LAID AT A CONTINUOUS AND CONSTANT GRADE FROM THE STREET SEWER CONNECTION TO THE FOUNDATION AT A GRADE OF NOT LESS THAN INCH PER FOOT. PIPE JOINTS MUST BE MADE UNDER DRY CONDITIONS. IF WATER IS PRESENT, ALL NECESSARY STEPS SHALL BE TAKEN TO DEWATER THE TRENCH.

- 7) TESTING: THE COMPLETED HOUSE SEWER SHALL BE SUBJECTED TO A LEAKAGE TEST IN ANY OF THE FOLLOWING MANNERS: (PRIOR TO BACKFILLING)

- A. AN OBSERVATION TEE SHALL BE INSTALLED AS SHOWN AND WHEN READY FOR TESTING, AN INFLATABLE BLADDER OR PLUG SHALL BE INSERTED JUST UPSTREAM FROM THE OPENING IN THE TEE. AFTER INFLATION, WATER SHALL BE INTRODUCED INTO THE SYSTEM ABOVE THE PLUG TO A HEIGHT OF 5 FEET ABOVE THE LEVEL OF THE PLUG.
- B. THE PIPE SHALL BE LEFT EXPOSED AND LIBERALLY HOSED WITH WATER, TO SIMULATE, AS NEARLY AS POSSIBLE, WET TRENCH CONDITIONS OR, IF TRENCH IS WET, THE GROUND WATER SHALL BE PERMITTED TO RISE IN THE TRENCH OVER THE PIPE. INSPECTIONS FOR LEAKS SHALL BE MADE THROUGH THE CLEANOUT WITH A FLASHLIGHT.
- C. DRY FLUORESCENCE DYE SHALL BE SPRINKLED INTO THE TRENCH OVER THE PIPE. IF THE TRENCH IS DRY, THE PIPE SHALL BE LIBERALLY HOSED WITH WATER, OR IF THE TRENCH IS WET, GROUND WATER SHALL BE PERMITTED TO RISE IN THE TRENCH OVER THE PIPE. OBSERVATION FOR LEAKS SHALL BE MADE IN THE FIRST DOWN-STREAM MANHOLE.

LEAKAGE OBSERVED IN ANY ONE OF THE ABOVE ALTERNATE TESTS SHALL BE CAUSE FOR NON-ACCEPTANCE AND THE PIPE SHALL BE DUG-UP IF NECESSARY AND RE-LAID SO AS TO ASSURE WATER TIGHTNESS.

- 8) ILLEGAL CONNECTIONS: NOTHING BUT SANITARY WASTE FLOW FROM HOUSE TOILETS, SINKS, LAUNDRY ETC. SHALL BE PERMITTED. ROOF LEADERS, FOOTING DRAINS, SLUMP PUMPS OR OTHER SIMILAR CONNECTIONS CARRYING RAIN WATER, DRAINAGE OR GROUND WATER SHALL NOT BE PERMITTED.
- 9) HOUSE WATER SERVICE SHALL NOT BE LAID IN SAME TRENCH AS SEWER SERVICE.
- 10) BEDDING: SCREENED GRAVEL AND/OR CRUSHED STONE FREE FROM CLAY, LOAM, ORGANIC MATERIAL AND MEETING ASTM C33-87.

100% PASSING	1 INCH SCREEN
90%-100% PASSING	3/4 INCH SCREEN
20%-55% PASSING	3/8 INCH SCREEN
0%-10% PASSING	#4 SIEVE
0%-5% PASSING	#8 SIEVE

WHERE ORDERED BY THE ENGINEER TO STABILIZE THE TRENCH BASE, SCREENED GRAVEL OR CRUSHED STONE 1/2 INCH TO 1 1/2 INCH SHALL BE USED.

- 11) LOCATION: THE LOCATION OF THE TEE OR WYE SHALL BE RECORDED AND FILED IN THE MUNICIPAL RECORDS. IN ADDITION, A FERROUS METAL ROD OR PIPE SHALL BE PLACED OVER THE TEE OR WYE AS DESCRIBED IN THE TYPICAL "CHIMNEY" DETAIL, TO AID IN LOCATING THE BURIED PIPE WITH A DIP NEEDLE OR PIPEFINDER.
- 12) CONCRETE: CONCRETE SHALL CONFORM TO THE REQUIREMENTS FOR CLASS A (3000 PSI) CONCRETE OF THE STATE OF NEW HAMPSHIRE DEPARTMENT OF TRANSPORTATION STANDARDS SPECIFICATIONS AS FOLLOWS:
CEMENT: 6.0 BAGS PER CUBIC YARD
WATER: 5.75 GALLONS PER BAG CEMENT
MAXIMUM SIZE OF AGGREGATE: 1 INCH
- 13) CHIMNEYS: IF VERTICAL DROP INTO SEWER IS GREATER THAN 4 FEET, A CHIMNEY SHALL BE CONSTRUCTED FOR THE HOUSE CONNECTION. CHIMNEY INSTALLATION AS RECOMMENDED BY THE PIPE MANUFACTURER MAY BE USED IF APPROVED BY THE ENGINEER.
- 14) MAINTAIN A 10" HORIZONTAL SEPARATION BETWEEN SEWER LINES AND WATER LINES, AND AN 18" VERTICAL SEPARATION AT SEWER AND WATER CROSSINGS, WITH WATER OVER SEWER.

TRITECH
ENGINEERING CORPORATION

285 CENTRAL AVENUE
DOVER, NEW HAMPSHIRE 03820
TELEPHONE 603 742 8077
FAX 603 742 3660

REVISIONS	DATE	DESCRIPTION

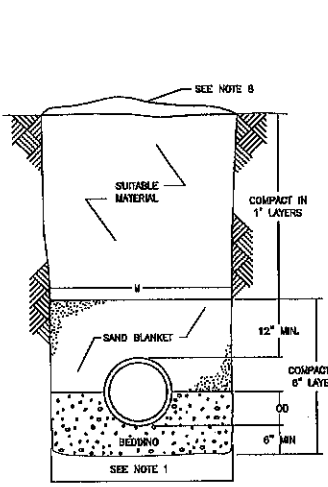
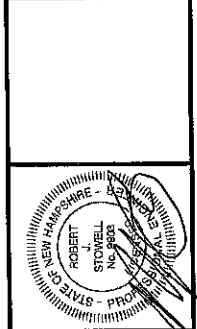

TYPICAL SECTION
NOT TO SCALE

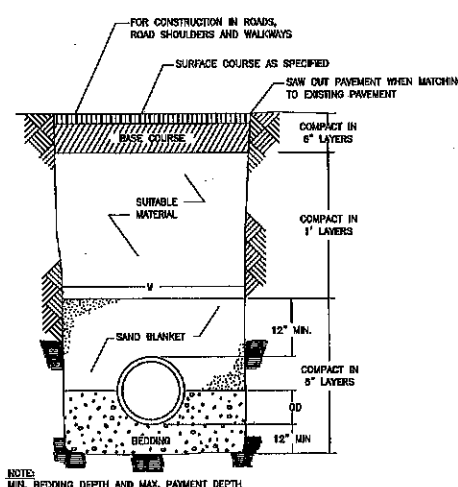

LEDGE CONSTRUCTION
NOT TO SCALE

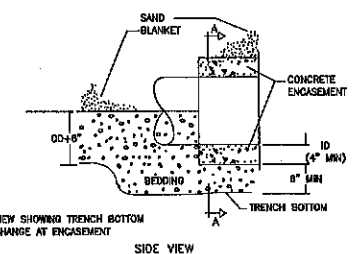

SECTION A-A
(SEE NOTE 10)

CONCRETE FULL ENCASEMENT
NOT TO SCALE

GENERAL NOTES

- 1) ORDERED EXCAVATION OF UNSUITABLE MATERIAL BELOW GRADE. REFILL WITH BEDDING MATERIAL FOR TRENCH WIDTH SEE NOTE 7.

- 2) BEDDING: SCREENED GRAVEL AND/OR CRUSHED STONE FREE FROM CLAY, LOAM, ORGANIC MATTER AND MEETING ASTM C33 STONE SIZE NO. 67.

100% PASSING	1 INCH SCREEN
90%-100% PASSING	3/4 INCH SCREEN
20%-55% PASSING	3/8 INCH SCREEN
0%-10% PASSING	#4 SIEVE
0%-5% PASSING	#8 SIEVE

WHERE ORDERED BY THE ENGINEER TO STABILIZE THE TRENCH BASE, GRADED SCREENED GRAVEL OR CRUSHED STONE 1/2 INCH TO 1 1/2 INCH SHALL BE USED.

- 3) SAND BLANKET: CLEAN SAND FREE FROM ORGANIC MATTER SO GRADED THAT 90%-100% PASSES A 1/2 INCH SIEVE AND NOT MORE THAN 15% WILL PASS A #200 SIEVE. BLANKET MAY BE OMITTED FOR DUCTILE IRON AND REINFORCED CONCRETE PIPE PROVIDED THAT NO STONE LARGER THAN 2 INCHES IS IN CONTACT WITH THE PIPE.

- 4) SUITABLE MATERIAL: IN ROADS, ROAD SHOULDERS, WALK-WAYS AND TRAVELED WAYS, SUITABLE MATERIAL FOR TRENCH BACKFILL SHALL BE THE NATURAL MATERIAL EXCAVATED DURING THE COURSE OF CONSTRUCTION, BUT SHALL EXCLUDE DEBRIS, PIECES OF PAVEMENT, ORGANIC MATTER, TOP SOIL, ALL WET OR SOFT MUCK, PEAT OR CLAY, ALL EXCAVATED LEDGE MATERIAL, AND ALL ROCKS OVER SIX INCHES IN LARGEST DIMENSION, OR ANY MATERIAL WHICH, AS DETERMINED BY THE ENGINEER, WILL NOT PROVIDE SUFFICIENT SUPPORT OR MAINTAIN THE COMPLETED CONSTRUCTION IN A STABLE CONDITION.

IN CROSS-COUNTRY CONSTRUCTION, SUITABLE MATERIAL SHALL BE AS DESCRIBED ABOVE, EXCEPT THAT THE ENGINEER MAY PERMIT THE USE OF TOP SOIL, LOAM, MUCK OR PEAT, IF HE IS SATISFIED THAT THE COMPLETED CONSTRUCTION WILL BE ENTIRELY STABLE AND PROVIDED THAT EASY ACCESS TO THE SEWER FOR MAINTENANCE AND POSSIBLY RECONSTRUCTION, WHEN NECESSARY WILL BE PRESERVED.

- 5) BASE COURSE, IF ORDERED BY THE ENGINEER, SHALL MEET THE REQUIREMENTS OF DIVISION 300 OF THE LATEST EDITION OF THE STANDARD SPECIFICATIONS FOR ROAD AND BRIDGE CONSTRUCTION OF THE STATE OF NEW HAMPSHIRE, DEPARTMENT OF TRANSPORTATION.

- 6) WOOD SHEETING, IF REQUIRED, WHERE SHEETING IS PLACED ALONGSIDE THE PIPE AND EXTENDS BELOW MID-DIAMETER, IT SHALL BE CUT OFF AND LEFT IN PLACE TO AN ELEVATION NOT LESS THAN 1 FOOT ABOVE THE TOP OF THE PIPE. WHERE SHEETING IS ORDERED BY THE ENGINEER TO BE LEFT IN PLACE, IT SHALL BE CUT OFF AT LEAST 3 FEET BELOW FINISHED GRADE, BUT NOT LESS THAN 1 FOOT ABOVE THE TOP OF THE PIPE.

- 7) W= MAXIMUM ALLOWABLE TRENCH WIDTH TO A PLANE 12 INCHES ABOVE THE PIPE. FOR PIPES 15 INCHES NOMINAL DIAMETER OR LESS, W SHALL BE NO MORE THAN 36 INCHES, FOR PIPES GREATER THAN 15 INCHES NOMINAL DIAMETER, W SHALL BE 24 INCHES PLUS PIPE O.D. W SHALL ALSO BE THE PAYMENT WIDTH FOR LEDGE EXCAVATION AND FOR ORDERED EXCAVATION BELOW GRADE.

- 8) FOR CROSS COUNTRY CONSTRUCTION, BACKFILL OR FILL SHALL BE MOUND TO A HEIGHT OF 6 INCHES ABOVE THE ORIGINAL GROUND SURFACE.

- 9) CONCRETE FOR ENCASEMENT SHALL CONFORM TO THE REQUIREMENTS FOR CLASS A (3000 LB) CONCRETE OF THE NEW HAMPSHIRE DEPARTMENT OF TRANSPORTATION STANDARD SPECIFICATIONS AS FOLLOWS: CEMENT: 6.0 BAGS PER CUBIC YARD
WATER: 5.75 GALLONS PER BAG CEMENT
MAXIMUM SIZE OF AGGREGATE: 1 INCH

- 10) IF FULL ENCASEMENT IS UTILIZED, DEPTH OF CONCRETE BELOW PIPE SHALL BE 1/4 I.D. (4" MIN.) BLOCK SUPPORT SHALL BE SOLID CONCRETE BLOCKS.

RECEIVED

JUL 02 2020

LAND USE OFFICE

SEWER DETAILS
BARRINGTON STORAGE-OFFICE

ROUTE #125
BARRINGTON, NEW HAMPSHIRE
NOVEMBER 11, 2019

JOB No. 19107

SHEET NO.

SP-9

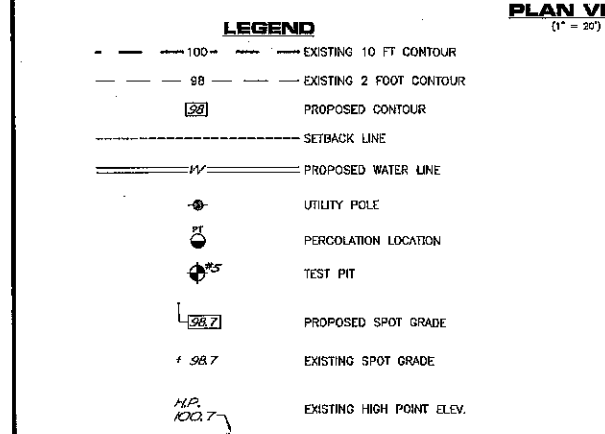
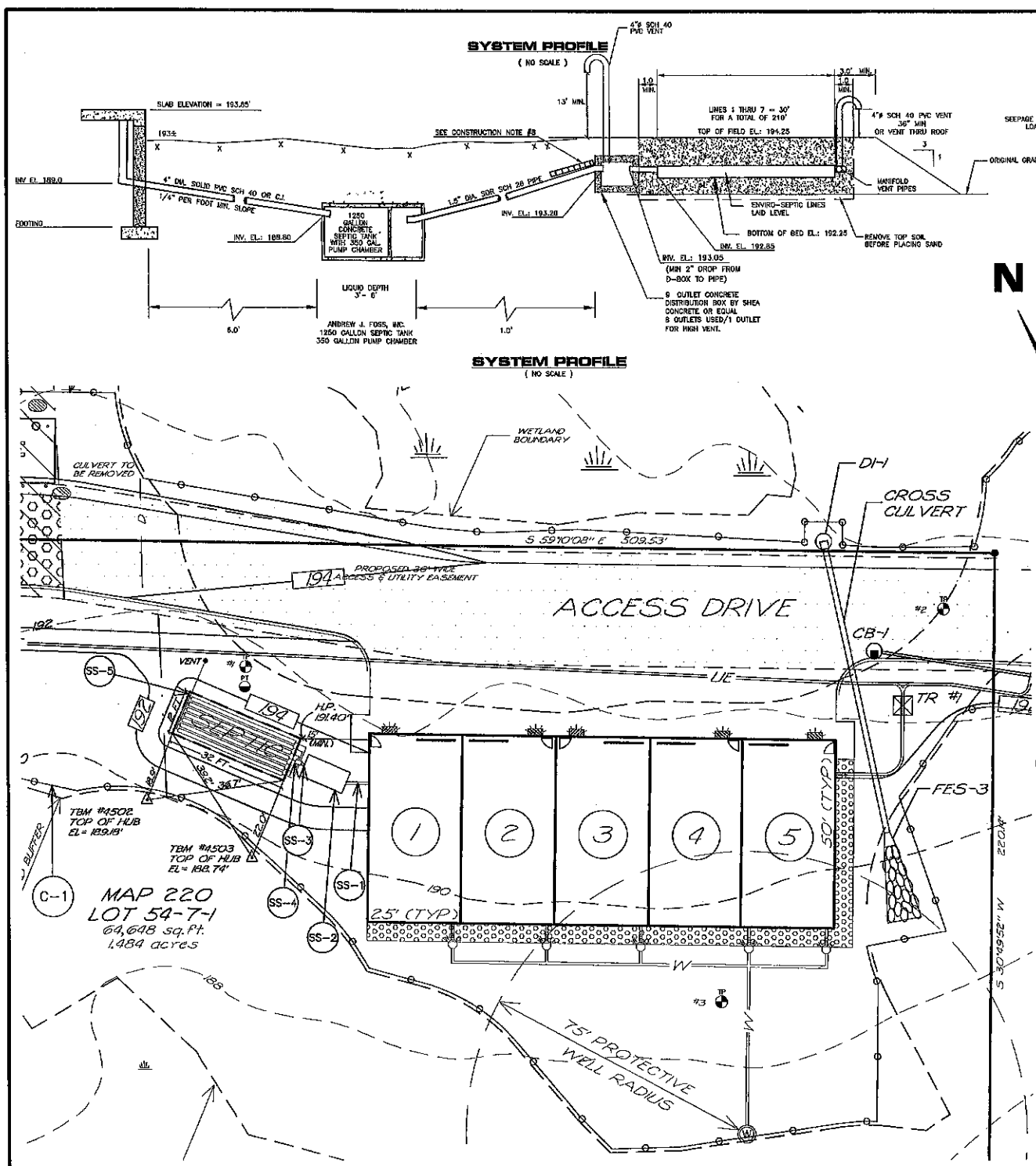

SAND SPECIFICATIONS

Screen Size	ASTM C-33 fine aggregate	AES & ES Specifications
3/4"		0% retained
3/8"	100% passing	"Gravel"
#4	95-100% passing	
#8	80-100% passing	<35% retained
#10		
#16	50-85% passing	"Coarse to Very Coarse Sand"
#30	25-60% passing	
#35		40-90% retained
#40		
#50	5-30% passing	
#100	0-10% passing	
#200		"Fines" (all & clay) <22% passing - CRITICAL

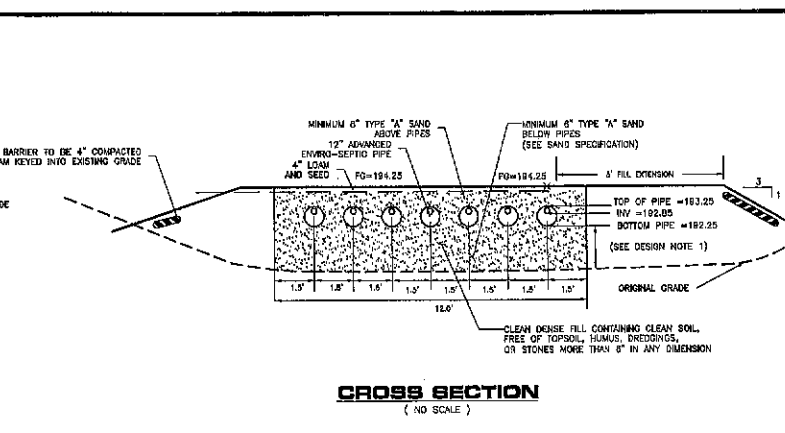

TEST PIT #1

DATE: JULY 30, 2019
DEPTH: DESCRIPTION:

0" - 7"	DARK BROWN (10YR 4/3) FINE SANDY LOAM; WEAK FINE GRANULAR STRUCTURE; MOIST, FRAGILE.
7" - 14"	DARK YELLOWISH BROWN (10YR 4/8) SANDY LOAM; MODERATE MEDIUM GRANULAR STRUCTURE; MOIST, FRAGILE.
14" - 30"	OLIVE GRAY (2.5Y 5/2) SILT LOAM; MANY REDOX DEPLETIONS AND CONCENTRATIONS; MODERATE MEDIUM BLOCKY STRUCTURE; MOIST, FIRM.
30" - 54"	OLIVE GRAY (5Y 5/3) SILTY CLAY LOAM; MANY REDOX DEPLETIONS AND CONCENTRATIONS; STRONG MEDIUM BLOCKY STRUCTURE; MOIST, VERY FIRM.

ESTIMATED WATER TABLE: 14" - REDOX FEATURES
OBSERVED WATER TABLE: 50"
RESTRICTIVE LAYER: 30"
BEDROCK REFUSAL: NONE
SOIL SERIES: ELDRIDGE
HYDROLOGIC SOIL GROUP: 3

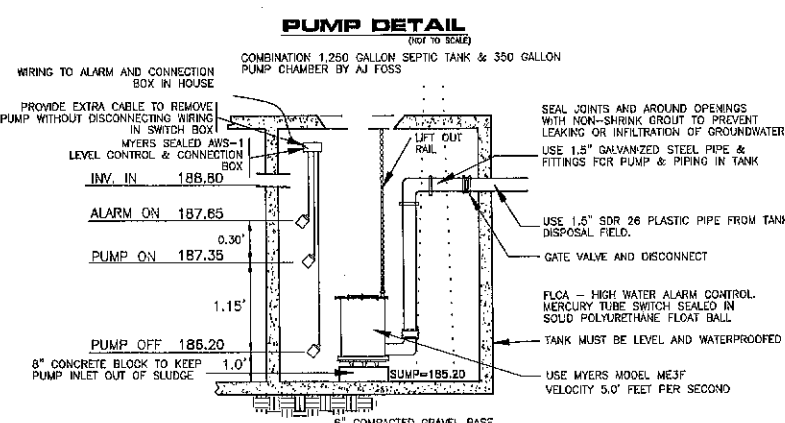

PUMP REQUIREMENTS

PUMP TO BE CAPABLE OF 22 GPM AND A TOTAL HEAD OF 16.5 FT
H VERTICAL + H FRICTION = H TOTAL
8.0 + 8.5 = 16.5 FEET
PUMP MODEL: MEYERS MODEL M3F

DOSE REQUIREMENTS

FLOAT SET TO DOSE AT 100 GALS. PER CYCLE.
1 FT. DRAW DOWN = 88 GALS.
PUMP SET TO DOSE 3 TIMES PER DAY
APPROX. RUNNING TIME 3.7 MIN. PER CYCLE WITH SPECIFIED PUMP.
(RUNNING TIME TO BE NO LESS THAN 3 MIN. AND NOT TO EXCEED 10 MIN.)

SEPTIC NOTES:

- INSTALL 6 FEET OF 4" SEWER PIPE.
- INSTALL COMBINATION 1,250 GALLON CONCRETE SEPTIC TANK & 350 GALLON PUMP CHAMBER BY AJ FOSS
- INSTALL 1 FOOT OF PUMP DISCHARGE PIPE.
- INSTALL SHEA CONCRETE, 9 OUTLET DISTRIBUTION BOX OR EQUAL.
- INSTALL 32' x 12' ADVANCED ENVIRO-SEPTIC (AES), 7 PIPES, 30 FEET LONG

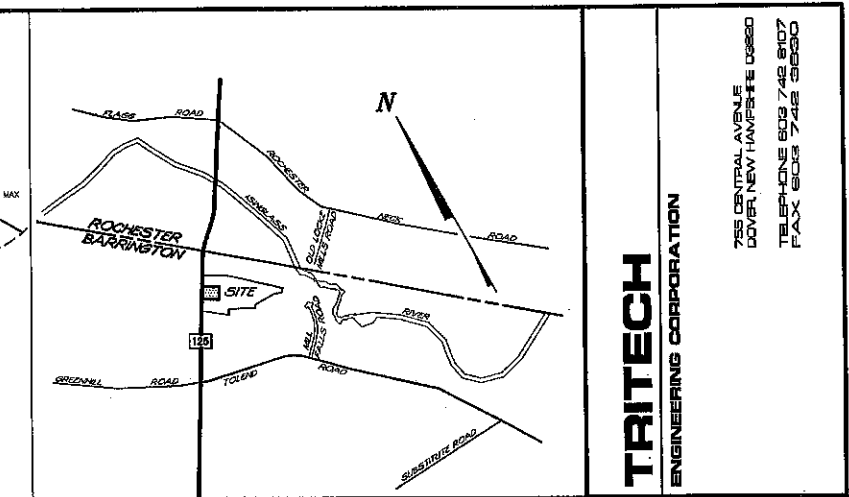

DESIGN NOTES

- DESIGN INTENT:
 - EXISTING GRADE AT THE HIGH POINT OF THE SYSTEM IS ELEV 191.40'
 - ESTIMATED SEASONAL HIGH WATER TABLE IN TEST PIT #1 IS 14"
 - BOTTOM OF AES PIPE TO BE INSTALLED AT ELEV. 192.25' PROVIDING 24" OF SEPARATION TO SLOTT (24" REQUIRED).
 - BOTTOM OF AES PIPE TO BE INSTALLED 10" ABOVE EXISTING GRADE AT THE HIGH POINT OF THE SYSTEM.
- PERCOLATION TEST: DATE: JULY 30, 2019
DEPTH: 24" INCHES
RATE: 14 MINUTES PER INCH
- DESIGN FLOW DATA: 300 GPD (MIN ALLOWABLE FLOW)
- BED SIZE: 198 LINEAR FEET REQUIRED, 7 PIPES x 30' PROVIDED = 210 LINEAR FEET PROVIDED
- STAFFORD COUNTY SOIL CLASSIFICATION: ELDRIDGE
- LOT SERVICED BY PRIVATE WATER SYSTEM (COMMUNITY WELL).
- NO EXPOSED LEDGE WITHIN 75' OF SYSTEM.
- FOUNDATION GRABS ARE PERMITTED 15' FROM PROPOSED LEACH FIELD AND 5' FROM PROPOSED SEPTIC TANK. A SOLID FOUNDATION DRAIN LINE IS PERMITTED 5' FROM LEACH FIELD.
- IF FAILURE OCCURS SYSTEM MAY HAVE TO BE REBUILT IN PLACE.
- NO SURFACE WATER WITHIN 75' OF SYSTEM.
- A GARBAGE DISPOSAL IS NOT PERMITTED.
- WATER SOFTENER IS NOT PERMITTED
- LARGE WHIRLPOOLS OR HOT TUBS ARE NOT RECOMMENDED.
- NHDES SUBDIVISION APPROVAL NUMBER PENDING.

CONSTRUCTION NOTES

- THIS SUBSURFACE DISPOSAL SYSTEM HAS BEEN DESIGNED IN ACCORDANCE WITH THE RULES, REGULATIONS, STANDARDS AND PRACTICES OF THE NEW HAMPSHIRE WATER SUPPLY AND POLLUTION CONTROL DIVISION (NHWSPCD). CONSTRUCTION MUST BE DONE IN ACCORDANCE WITH THIS PLAN AND THE CONSTRUCTION CRITERIA OF NHWSPCD. IN ADDITION, THE INSTALLER MUST HOLD A VALID INSTALLER'S PERMIT FROM NHWSPCD, BEFORE BACKFILLING OR COVERING THE INSTALLED COMPONENTS. THE INSTALLER MUST NOTIFY THE NHWSPCD FOR INSPECTION.
- UNLESS NOTED OTHERWISE, SEPTIC TANK AND DISTRIBUTION BOXES ARE TO BE PRE-CAST CONCRETE, AND ARE TO BE SET ON FIRMLY COMPACTED GROUND. PIPE CONNECTIONS AT INLET AND OUTLET SHALL BE TIGHTLY SEALED WITH CEMENT TYPE MORTAR, SUCH AS WATERLOO. SEPTIC TANK AND DISTRIBUTION BOXES SHALL HAVE INLET Baffles CAST IN. OUTLETS SHALL BE "WATER LEVELED" TO ENSURE EQUAL OUTLET DISTRIBUTION. INSULATE AS DETAILED.
- SEWER PIPE FROM BUILDING TO SEPTIC TANK SHALL BE CAST IRON OR SCHEDULE 40 SOLVENT WELDED PLASTIC PIPE. EFFLUENT PIPE FROM SEPTIC TANK TO LEACH FIELD SHALL BE FRICTION JOINT RIGID PLASTIC PIPE UNLESS NOTED OTHERWISE. LEACHING BED LATERAL PIPES SHALL BE PERFORATED RIGID PLASTIC PIPE WITH FRICTION TYPE COLLARS, BELL OR TEES, ALL ENDS INTERCONNECTED AND LAID LEVEL.
- ALL TOPSOIL, ROOTS AND ORGANIC MATTER MUST BE REMOVED FROM THE AREA BENEATH THE LEACH FIELD. WITH CARE TAKEN NOT TO COMPACT THE PARENT SOIL DURING CONSTRUCTION. FOR BASED SYSTEMS, THE FILL BENEATH THE FIELD SHALL BE CLEAN, MEDIUM COURSE SAND (0.5 - 1.0 MM), AND THE AREA TO BE FILLED MUST BE CLEARED.
- THE INSTALLER MUST CONTACT TRITECH ENGINEERING CORP. PRIOR TO CONSTRUCTION IF ANY DEVIATIONS BETWEEN THE SITE AND THIS PLAN ARE NOTED, OR IF ANY CONSTRUCTION CHANGES ARE DESIRED.
- NHWSPCD CONSTRUCTION APPROVALS EXPIRE 4 YEARS FROM THE DATE OF ISSUE.
- WHERE THE ACCESS COVER FOR THE SEPTIC TANK COMPARTMENT IS GREATER THAN 12" FROM FINISHED GRADE A 36" DIAMETER RISER SHALL BE INSTALLED IN ACCORDANCE WITH ENW-WG 1010.05
- INSTALL 2 LAYERS OF 2" x 2" RIGID BOARD INSULATION CENTERED OVER PIPE DISCHARGE LINE WHERE COVER IS LESS THAN 3 FEET. INSTALL PUMP DISCHARGE LINE TO DRAIN BACK TO PUMP CHAMBER.

GENERAL NOTES

- CURRENT OWNER: MILL FALLS REALTY, LLC
P.O. BOX 627
CENTER OSSISPEE, N.H.
- DEED REFERENCE: SORD BOOK 2821 PAGE 327
- TAX MAP 220 LOT 54-7-1

RECEIVED

JUL 02 2020

LAND USE OFFICE

PLAN REFERENCE: BOUNDARY LINE ADJUSTMENT AND SUBDIVISION PLAN
MILL FALLS REALTY, LLC &
DOROTHY A. PURVIS
REVOCABLE LIVING TRUST
ROUTE 125 & MILL FALLS ROAD
BARRINGTON, NEW HAMPSHIRE
TRITECH ENGINEERING CORPORATION
MAY 19, 2004 SORD 77-22

INDIVIDUAL SEWAGE DISPOSAL SYSTEM DESIGN

BARRINGTON STORAGE-OFFICE

TAX MAP 220 LOT 54-7-1
ROUTE #125 (CALEF HWY)
BARRINGTON, NEW HAMPSHIRE
NOVEMBER 11, 2019 JOB No. 19107
SCALE: 1" = 20'

16DS-1

TRITECH
ENGINEERING CORPORATION

755 CENTRAL AVENUE
DOVER, NEW HAMPSHIRE 03800
TELEPHONE 603.748.8107
FAX 603.748.8100

REVISIONS

DATE	DESCRIPTION
12-2-19	REVISED PER PLANNING COMMENTS
5-28-20	GENERAL REVISIONS

DESIGNER:
CHECKED:
DATE:

RECEIVED

JUL 02 2020

LAND USE OFFICE

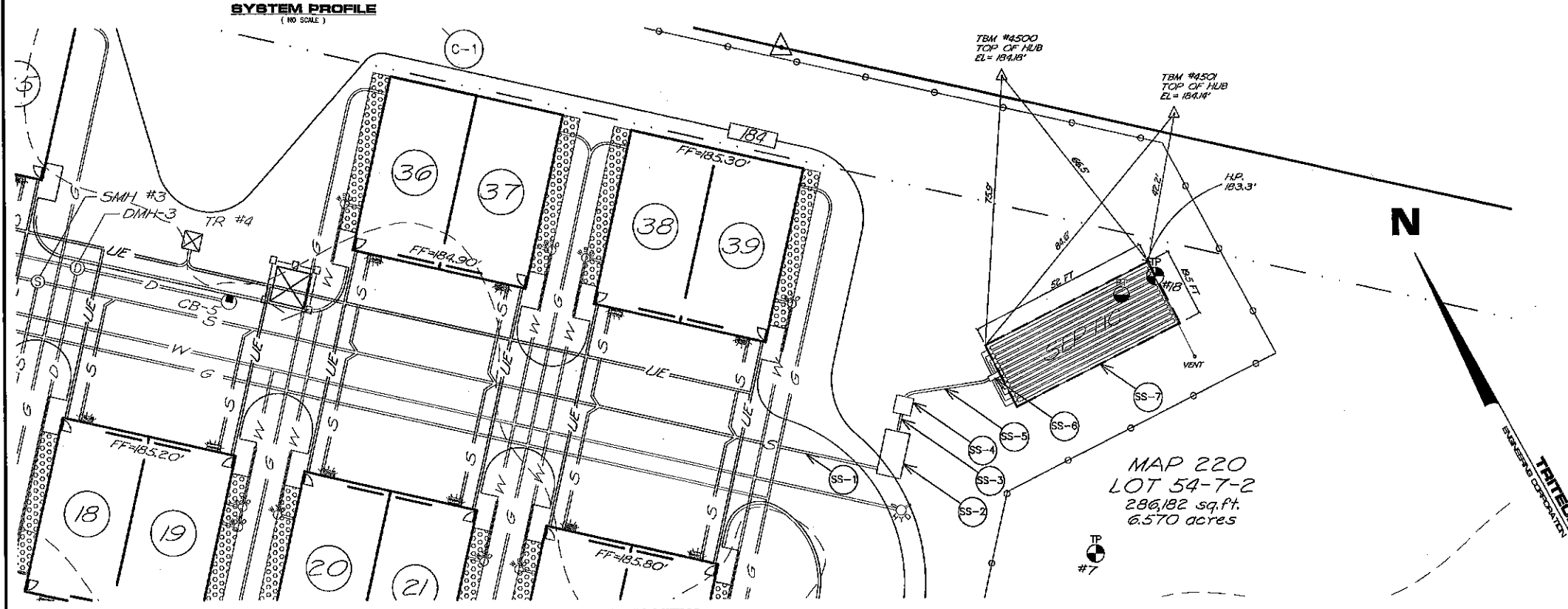
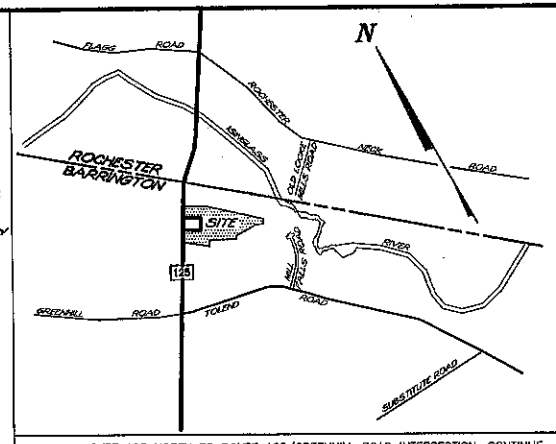
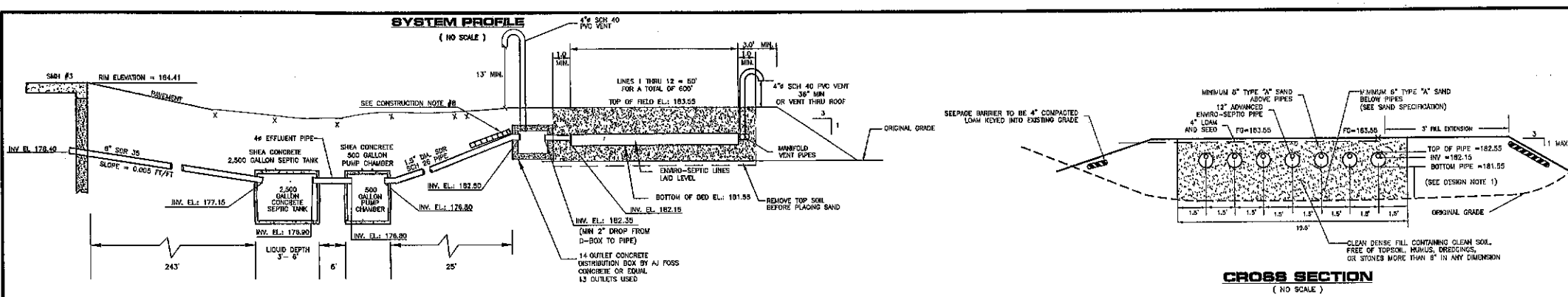

- ### DESIGN NOTES
- DESIGN INTENT:
 - ESTIMATED GRADE AT THE HIGH POINT OF THE SYSTEM IS ELEV. 183.30'
 - ESTIMATED SEASONAL HIGH WATER TABLE IN TEST PIT #1 IS 45'
 - BOTTOM OF AES PIPE TO BE INSTALLED AT ELEV. 181.55' PROVIDING 2" OF SEPARATION TO EARTH (2" REQUIRED).
 - BOTTOM OF AES PIPE TO BE INSTALLED 21" BELOW EXISTING GRADE AT THE HIGH POINT OF THE SYSTEM.
 - PERCOLATION TEST: DATE: JULY 30, 2019
DEPTH: 24" INCHES
RATE: 6 MINUTES PER INCH
 - DESIGN FLOW DATA: 1,200 GPD
 - BED SIZE: 600 LINEAR FEET REQUIRED, 12 PIPES x 50' PROVIDED = 600 LINEAR FEET PROVIDED
 - STRAFFORD COUNTY SOIL CLASSIFICATION: ELDRIDGE, WELL DRAINED, DEEP PHASE
 - LOT SERVICED BY PRIVATE WATER SYSTEM, (COMMUNITY WELL).
 - NO EXPOSED LEDGE WITHIN 75' OF SYSTEM.
 - FOUNDATION DRAINS ARE PERMITTED 15' FROM PROPOSED LEACH FIELD AND 5' FROM PROPOSED SEPTIC TANK. A SOLID FOUNDATION DRAIN LINE IS PERMITTED 3' FROM LEACH FIELD.
 - IF FAILURE OCCURS SYSTEM MAY HAVE TO BE REBUILT IN PLACE.
 - NO SURFACE WATER WITHIN 75' OF SYSTEM.
 - A GARBAGE DISPOSAL IS NOT PERMITTED.
 - WATER SOFTENER IS NOT PERMITTED.
 - LARGE WHIRLPOOLS OR HOT TUBS ARE NOT RECOMMENDED.
 - NHDES SUBDIVISION APPROVAL NUMBER: PENDING.

- ### CONSTRUCTION NOTES
- THIS SUBSURFACE DISPOSAL SYSTEM HAS BEEN DESIGNED IN ACCORDANCE WITH THE RULES, REGULATIONS, STANDARDS AND PRACTICES OF THE NEW HAMPSHIRE WATER SUPPLY AND POLLUTION CONTROL DIVISION (NHWSPCD). CONSTRUCTION MUST BE DONE IN ACCORDANCE WITH THIS PLAN AND THE CONSTRUCTION CRITERIA OF NHWSPCD. IN ADDITION, THE INSTALLER MUST HOLD A VALID INSTALLER'S PERMIT FROM NHWSPCD. BEFORE SHAKING OR COVERING THE INSTALLED COMPONENTS, THE INSTALLER MUST NOTIFY THE NHWSPCD FOR INSPECTION.
 - UNLESS NOTED OTHERWISE, SEPTIC TANK AND DISTRIBUTION BOXES ARE TO BE PRE-CAST CONCRETE, AND ARE TO BE SET ON FIRMLY COMPACTED GROUND. PIPE CONNECTIONS AT INLET AND OUTLET SHALL BE TIGHTLY SEALED WITH CEMENT TYPE MORTAR, SUCH AS WATERPLUG. SEPTIC TANK AND DISTRIBUTION BOXES SHALL HAVE INLET BAYPLES CAST IN. OUTLETS SHALL BE "WATER LEVELED" TO ENSURE EQUAL OUTLET DISTRIBUTION. INSULATE AS DETAILED.
 - SEWER PIPE FROM BUILDING TO SEPTIC TANK SHALL BE CAST IRON OR SCHEDULE 40 SOLVENT WELDED PLASTIC PIPE. EFFLUENT PIPE FROM SEPTIC TANK TO LEACH FIELD SHALL BE FRICTION JOINT RIGID PLASTIC PIPE UNLESS NOTED OTHERWISE. LEACHING BED LATERAL PIPES SHALL BE PERFORATED RIGID PLASTIC PIPE WITH FRICTION TYPE COLLARS, ELL OR TEES, ALL ENDS INTERCONNECTED AND LAID LEVEL.
 - ALL TOPSOIL, ROOTS AND ORGANIC MATTER MUST BE REMOVED FROM THE AREA BENEATH THE LEACH FIELD, WITH CARE TAKEN NOT TO COMPACT THE PARENT SOIL. DURING CONSTRUCTION FOR RAISED SYSTEMS, THE FILL BENEATH THE FIELD SHALL BE CLEAN, MEDIUM GRADE SAND (0.5 - 1.0 MM), AND THE AREA TO BE FILLED MUST BE CLEANED.
 - THE INSTALLER MUST CONTACT TRITECH ENGINEERING CORP. PRIOR TO CONSTRUCTION IF ANY DEVIATIONS BETWEEN THE SITE AND THIS PLAN ARE NOTED, OR IF ANY CONSTRUCTION CHANGES ARE DESIRED.
 - NHWSPCD CONSTRUCTION APPROVALS EXPIRE 4 YEARS FROM THE DATE OF ISSUE.
 - WHERE THE ACCESS COVER FOR THE SEPTIC TANK COMPARTMENT IS GREATER THAN 12" FROM FINISHED GRADE A 36" DIAMETER RISER SHALL BE INSTALLED IN ACCORDANCE WITH ENV-vq 1010.05
 - INSTALL 2 LAYERS OF 2" x 2" RIGID BOARD INSULATION CENTERED OVER PIPE DISCHARGE LINE WHERE COVER IS LESS THAN 3 FEET. INSTALL PUMP DISCHARGE LINE TO DRAIN BACK TO PUMP CHAMBER.

- ### GENERAL NOTES
- CURRENT OWNER: MILL FALLS REALTY, LLC
P.O. BOX 827
CENTER OSSISPEE, N.H.
 - DEED REFERENCE: SCRD BOOK 2821 PAGE 327
 - TAX MAP 220 LOT 54-7-2
 - DURING 2019, HIGHLAND SOILS (MICHAEL MARIANO, STATE OF NEW HAMPSHIRE CERTIFIED SOIL SCIENTIST #78) CONDUCTED AN ON-SITE WETLANDS DELINEATION OF THE SUBJECT PARCEL. WETLANDS WERE IDENTIFIED BASED ON THE CITY OF DOVER ZONING ORDINANCE (170-27.1) AND ON STATE & FEDERAL CRITERIA OUTLINED IN THE BARRINGTON WETLANDS DELINEATION MANUAL (DEPT. OF THE ARMY, 1983). ON THIS SITE, WETLANDS BASED ON LOCAL CRITERIA SHARE THE SAME QUALITIES WITH THOSE BASED ON STATE AND FEDERAL CRITERIA.
 - PLAN REFERENCE: BOUNDARY LINE ADJUSTMENT AND SUBDIVISION PLAN MILL FALL REALTY, LLC & DOROTHY A. PURVIS REVOCABLE LIVING TRUST ROUTE 125 & MILL FALLS ROAD BARRINGTON, NEW HAMPSHIRE TRITECH ENGINEERING CORPORATION MAY 19, 2004 SCRD 77-22

LEGEND

- 100' --- EXISTING 10 FT CONTOUR
- 98' --- EXISTING 2 FOOT CONTOUR
- 98' --- PROPOSED CONTOUR
- SETBACK LINE
- PROPOSED WATER LINE
- UTILITY POLE
- PERCOLATION LOCATION
- TEST PIT
- PROPOSED SPOT GRADE
- EXISTING SPOT GRADE
- EXISTING HIGH POINT ELEV.

SAND SPECIFICATIONS

Sieve Size	ASTM C-33 fine aggregate	AES & ES Specifications
3/4"	100% passing	0% retained
#4	95-100% passing	"Gravel"
#8	80-100% passing	
#10		<35% retained
#16	50-85% passing	"Coarse to Very Coarse Sand"
#30	25-60% passing	
#35		40-80% retained
#40		
#50	5-30% passing	
#100	0-10% passing	
#200		"Fines" (silt & clay) <2% passes - CRITICAL

TEST PIT #18

DATE: JULY 30, 2019

DEPTH:

0" - 5"	DARK BROWN (10YR 4/3) FINE SANDY LOAM; WEAK FINE GRANULAR STRUCTURE; MOIST, FRIABLE.
6" - 11"	YELLOWISH BROWN (10YR 5/6) FINE SANDY LOAM; MODERATE MEDIUM GRANULAR STRUCTURE; MOIST, FRIABLE.
11" - 24"	LIGHT OLIVE BROWN (2.5Y 5/4) FINE SANDY LOAM; MODERATE MEDIUM GRANULAR STRUCTURE; MOIST, FRIABLE.
24" - 45"	YELLOWISH BROWN (10YR 5/8) LOAMY SAND; WEAK MEDIUM GRANULAR STRUCTURE; MOIST, FRIABLE.
45" - 52"	YELLOWISH BROWN (10YR 5/8) LOAMY FINE SAND; FEW REDOX DEPLETIONS IN 10YR 6/1; MASSIVE STRUCTURE; MOIST, FRIABLE.
52" - 60"	OLIVE GRAY (2.5Y 5/2) & YELLOWISH BROWN (10YR 5/8) SILTY CLAY LOAM; MANY REDOX DEPLETIONS AND CONCENTRATIONS; STRONG MEDIUM BLOCKY STRUCTURE; MOIST, VERY FIRM.

ESTIMATED WATER TABLE: 45"
OBSERVED WATER TABLE: NONE
RESTRICTIVE LAYER: 52"
BEDROCK REFUSAL: NONE
SOIL SERIES: ELDRIDGE, WELL DRAINED, DEEP PHASE
HYDROLOGIC SOIL GROUP: 3

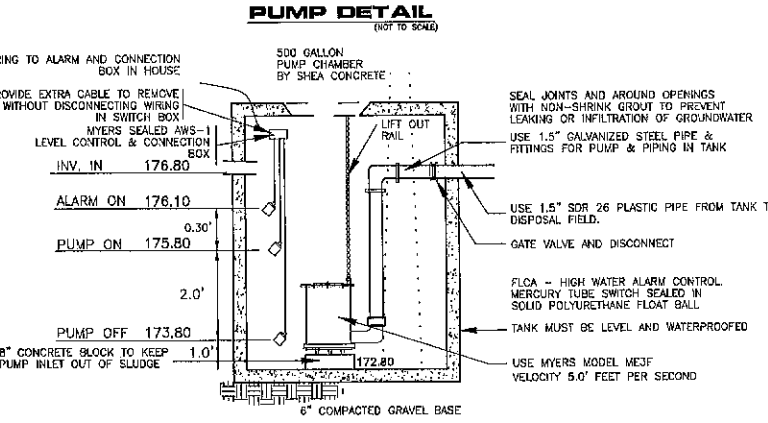

PUMP REQUIREMENTS

PUMP TO BE CAPABLE OF 42 GPM AND A TOTAL HEAD OF 15.5 FT
H VERTICAL + H FRICTION = H TOTAL
9.70 + 8.5 = 18.2 FEET
PUMP MODEL: MEYERS MODEL ME3F

DOSE REQUIREMENTS

FLOAT SET TO DOSE AT 300 GALS. PER CYCLE.
1 FT. DRAW DOWN = 15.5 GALS.
PUMP SET TO DOSE 3 TIMES PER DAY
APPROX. RUNNING TIME 7.15 MIN. PER CYCLE WITH SPECIFIED PUMP.
(RUNNING TIME TO BE NO LESS THAN 3 MIN. AND NOT TO EXCEED 10 MIN.)

- ### SEPTIC NOTES:
- INSTALL 243 FEET OF 6" SDR 35 SEWER PIPE. SEE SHEETS ISDS 2a & 2b, FOR COLLECTION SYSTEM DESIGN.
 - INSTALL 2 COMPARTMENT 2,500 GALLON CONCRETE SEPTIC TANK BY SHEA CONCRETE OR EQUAL.
 - INSTALL 5 FT OF 4" EFFLUENT PIPE.
 - INSTALL SHEA CONCRETE, CONCRETE 500 GA. PUMP CHAMBER BOX OR EQUAL.
 - INSTALL 25' OF 1 1/2" SDR 26 PUMP DISCHARGE PIPE.
 - INSTALL AJ FOSS CONCRETE, 14 OUTLET DISTRIBUTION BOX OR EQUAL.
 - INSTALL 52' x 19.5" ADVANCED ENVIRO-SEPTIC (AES), 12 PIPES, 50 FEET LONG

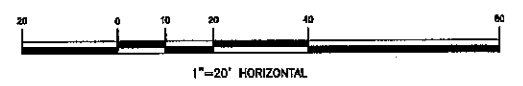
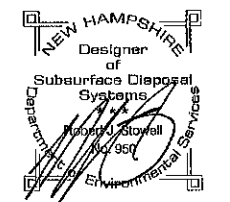

RECEIVED
JUL 02 2020
LAND USE OFFICE

TRITECH
ENGINEERING CORPORATION

785 CENTRAL AVENUE
DOVER, NEW HAMPSHIRE 03801
TEL: 603.808.7445 FAX: 603.807.7445
WWW: 603.808.7445

REVISIONS	DATE	DESCRIPTION
1	12-2-19	REVISED PER PLANNING COMMENTS
2	4-28-20	GENERAL REVISIONS

INDIVIDUAL SEWAGE
DISPOSAL SYSTEM DESIGN
BARRINGTON STORAGE-OFFICE
TAX MAP 220 LOT 54-7-2
ROUTE #125 (CALEF HWY)
BARRINGTON, NEW HAMPSHIRE
NOVEMBER 11, 2019 JOB No. 19107
SCALE: 1" = 20'

SHEET NO. **ISDS-2**

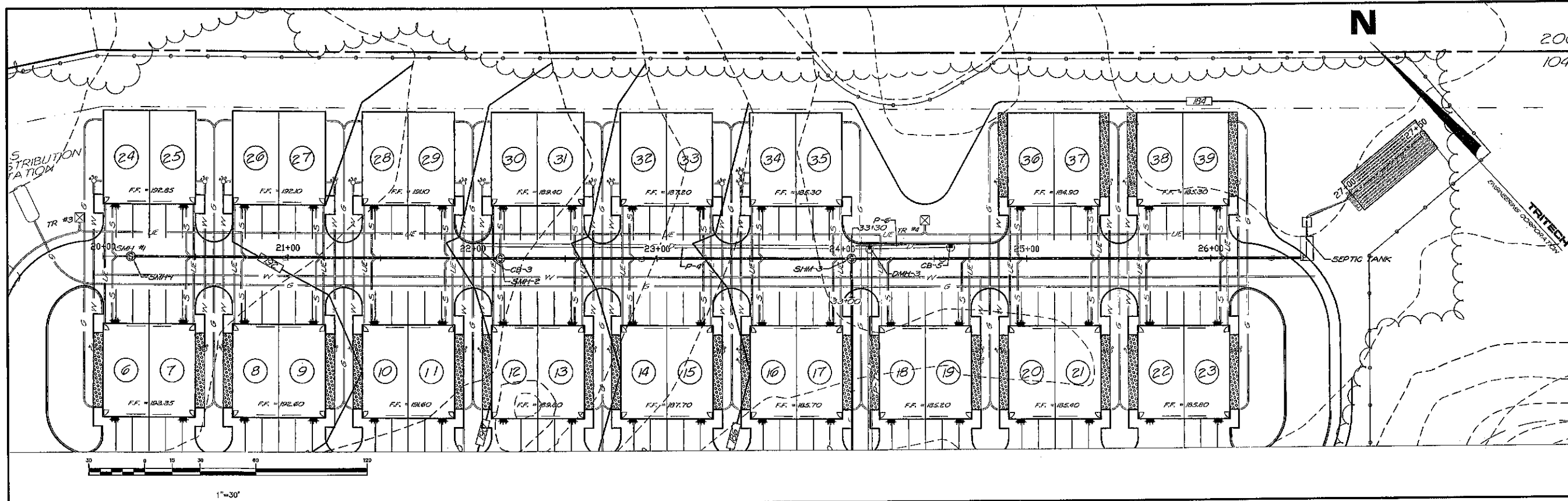

HORIZONTAL SCALE: 1" = 30'
 VERTICAL SCALE: 1" = 5'

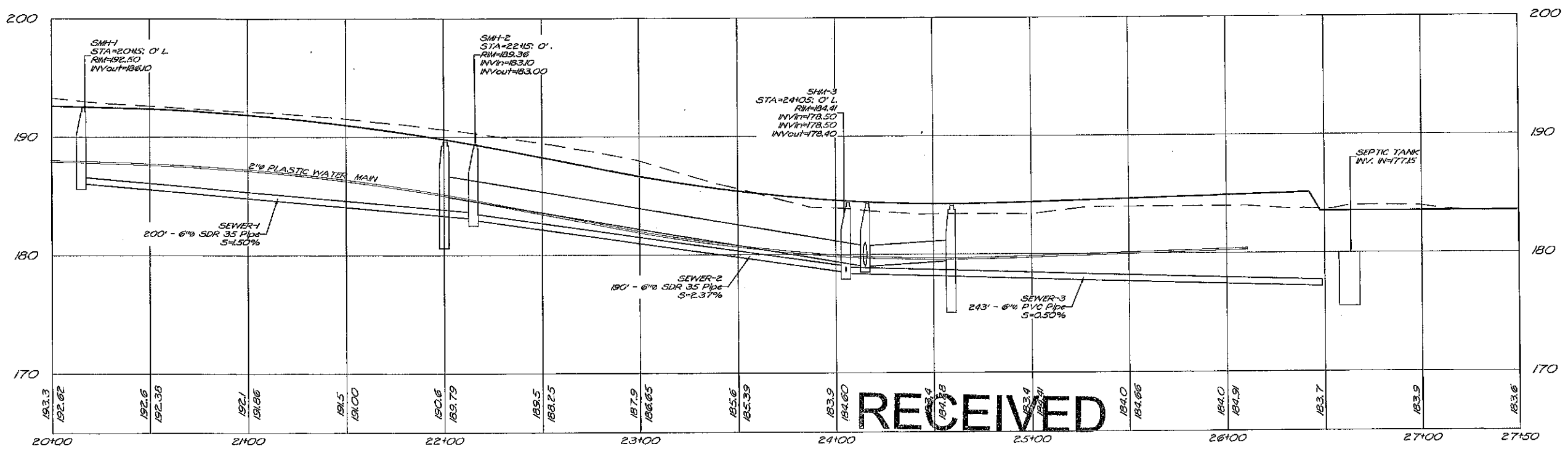

RECEIVED

JUL 02 2020

LAND USE OFFICE

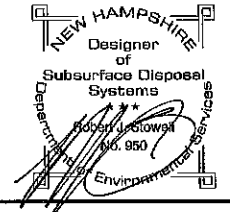

TRITECH
 ENGINEERING CORPORATION

766 CENTRAL AVENUE
 DOWVER, NEW HAMPSHIRE 03830
 TELEPHONE 603 748 8707
 FAX 603 748 9830

REVISIONS	DATE	DESCRIPTION
	5/29/20	ADDED TO PLAN SET
	6/30/20	REVISED PER PEER REVIEW

SEWER COLLECTION PLAN AND PROFILE
BARRINGTON STORAGE-OFFICE

ROUTE #125
 BARRINGTON, NEW HAMPSHIRE
 NOVEMBER 14, 2019 JOB No. 19107
 SCALE: 1" = 30'

SHEET No.

1SDS-2A

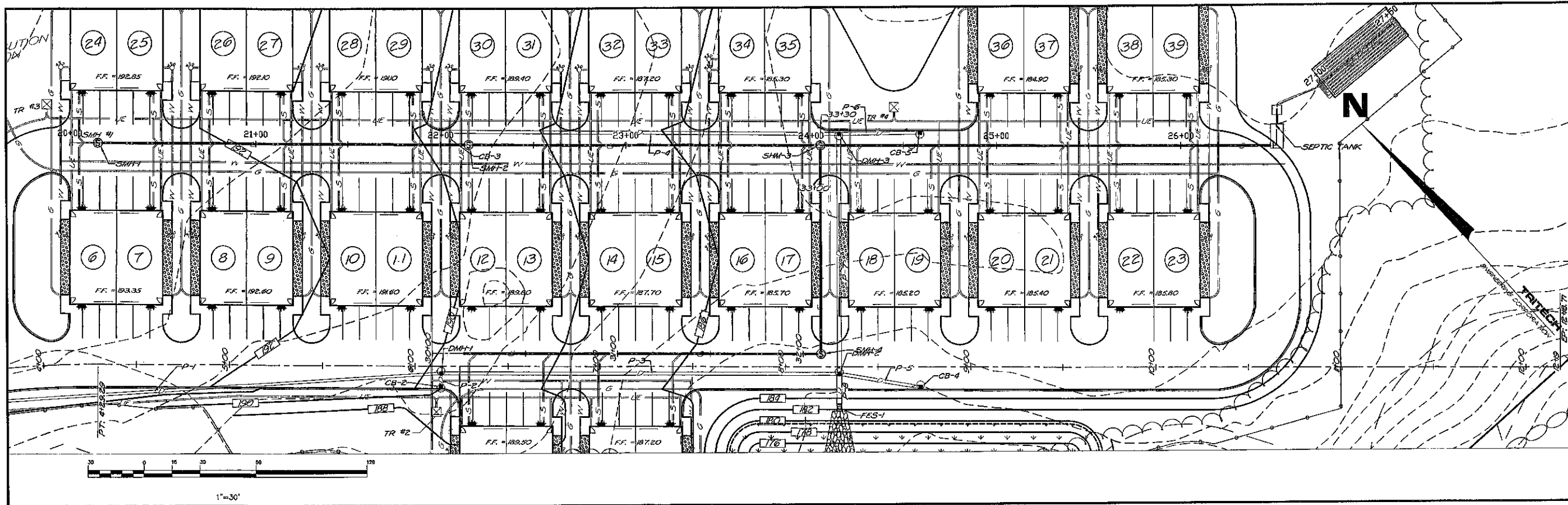

HORIZONTAL SCALE: 1" = 30'
 VERTICAL SCALE: 1" = 5'

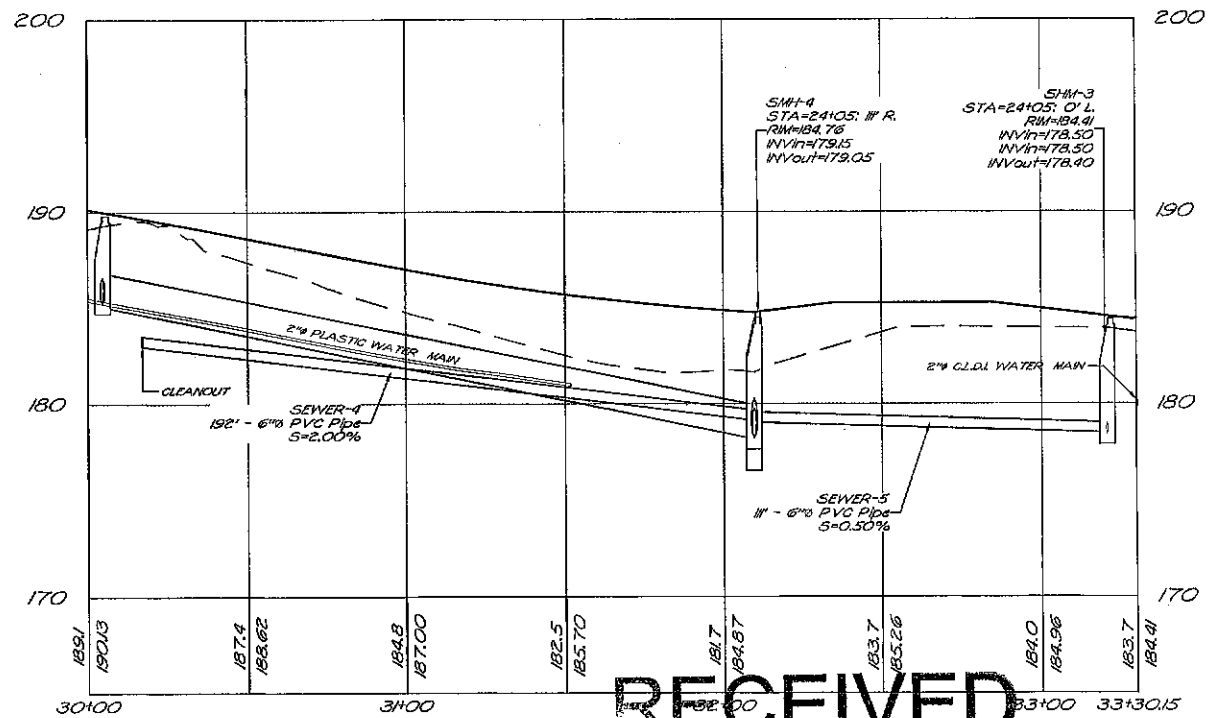

RECEIVED

JUL 02 2020

IND USE OFFICE

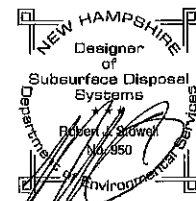

TRITECH
 ENGINEERING CORPORATION

785 CENTRAL AVENUE
 DOVER, NEW HAMPSHIRE 03860
 TELEPHONE 603 742 8007
 FAX 603 742 9860

REVISIONS	DATE	DESCRIPTION
1	5/29/20	ADDED TO PLAN SET
2	5/30/20	REVISED PER PEER REVIEW

SEWER COLLECTION PLAN AND PROFILE

BARRINGTON STORAGE-OFFICE

ROUTE #125
 BARRINGTON, NEW HAMPSHIRE
 NOVEMBER 14, 2019 JOB No. 19107
 SCALE: 1" = 30'

SHEET No.

18DS-2B

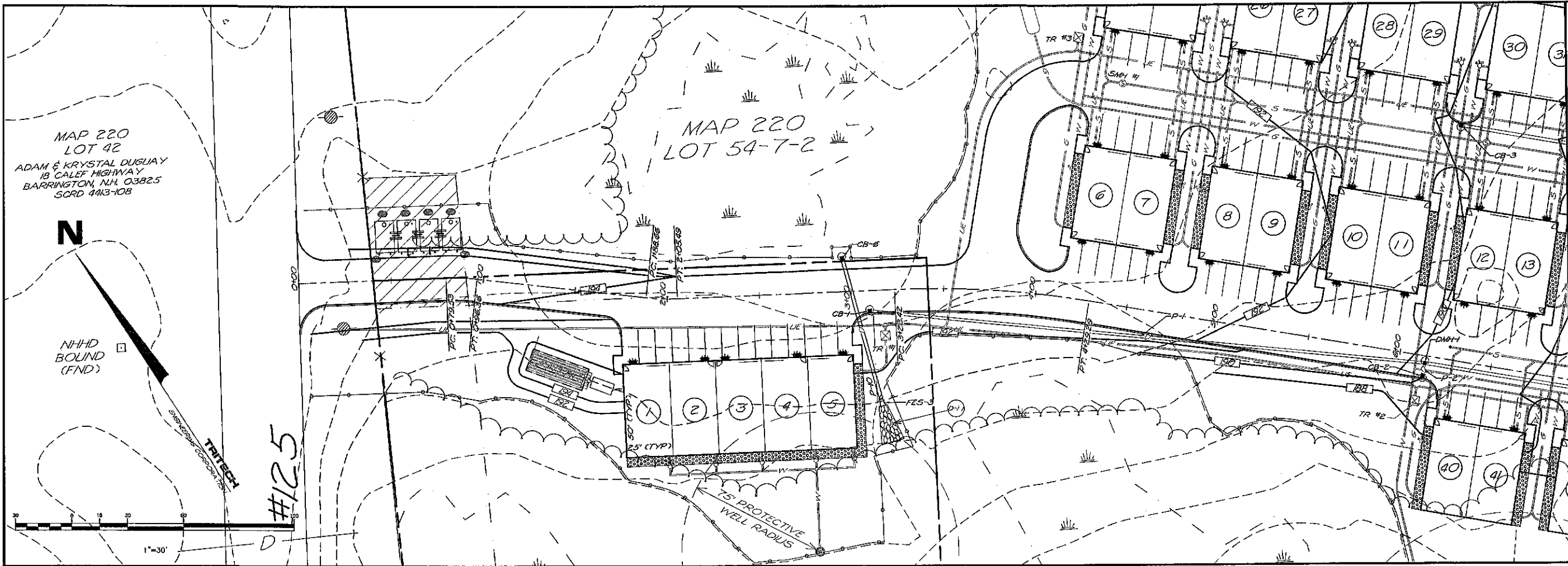

HORIZONTAL SCALE: 1" = 30'
VERTICAL SCALE: 1" = 5'

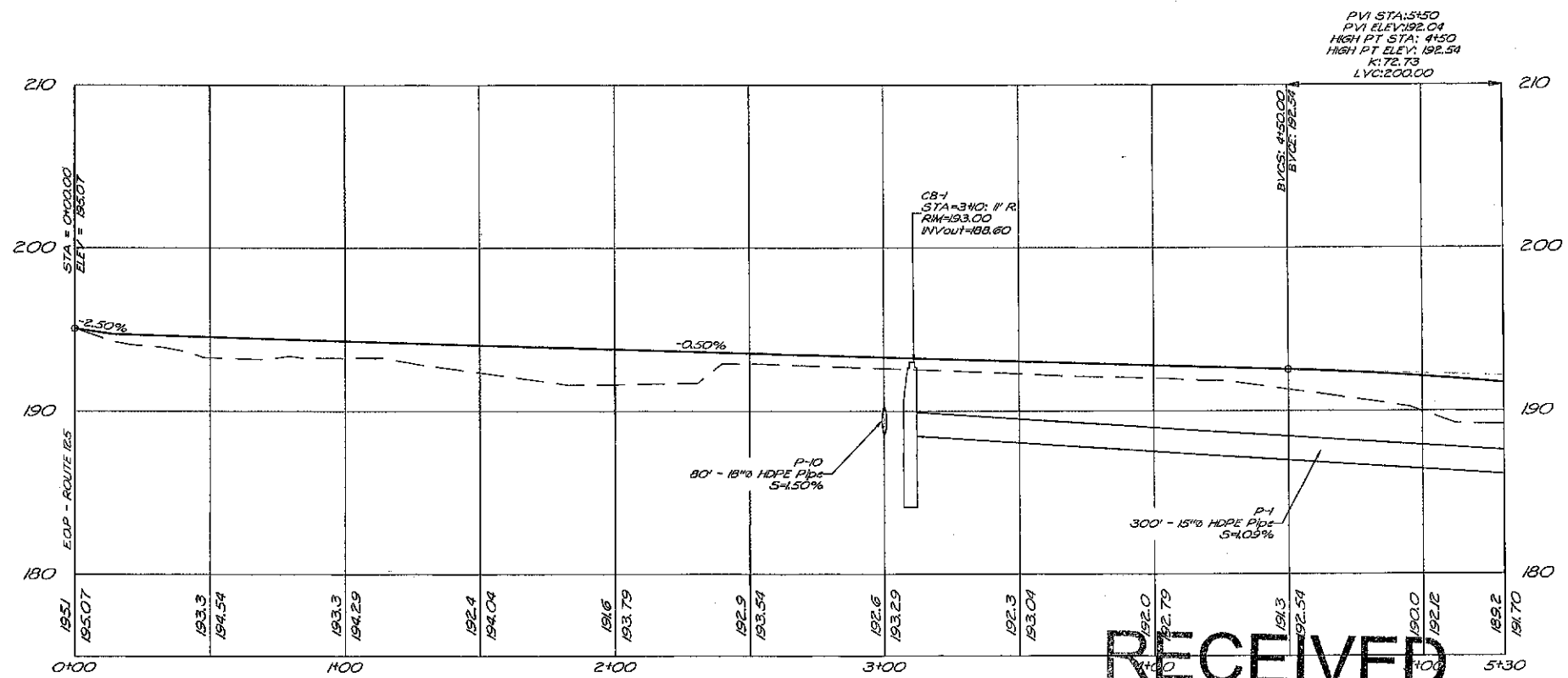

RECEIVED
JUL 02 2020

LAND USE OFFICE

TRITECH
ENGINEERING CORPORATION

REVISIONS DATE	DESCRIPTION
5/29/20	GENERAL REVISIONS
6/30/20	REVISED PER PEER REVIEW

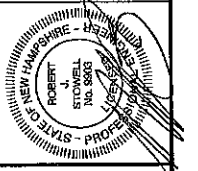

ROADWAY PLAN AND PROFILE
BARRINGTON STORAGE-OFFICE
ROUTE #125
BARRINGTON, NEW HAMPSHIRE
NOVEMBER 11, 2019 JOB No. 19107
SCALE: 1" = 30'

SHEET No.

0-1

788 CENTRAL AVENUE
DOVER, NEW HAMPSHIRE 03801
TELEPHONE 603 748 8107
FAX 603 748 9800

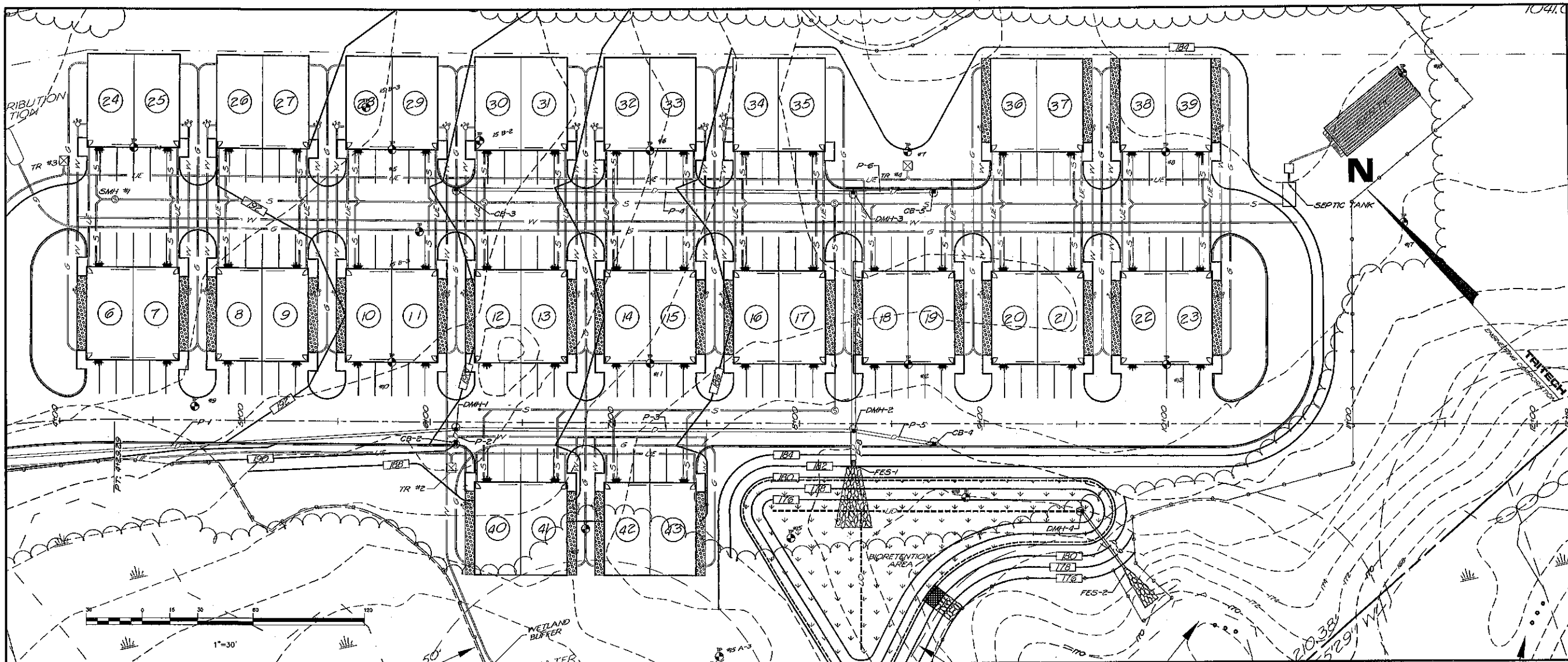

HORIZONTAL SCALE: 1" = 30'
 VERTICAL SCALE: 1" = 5'

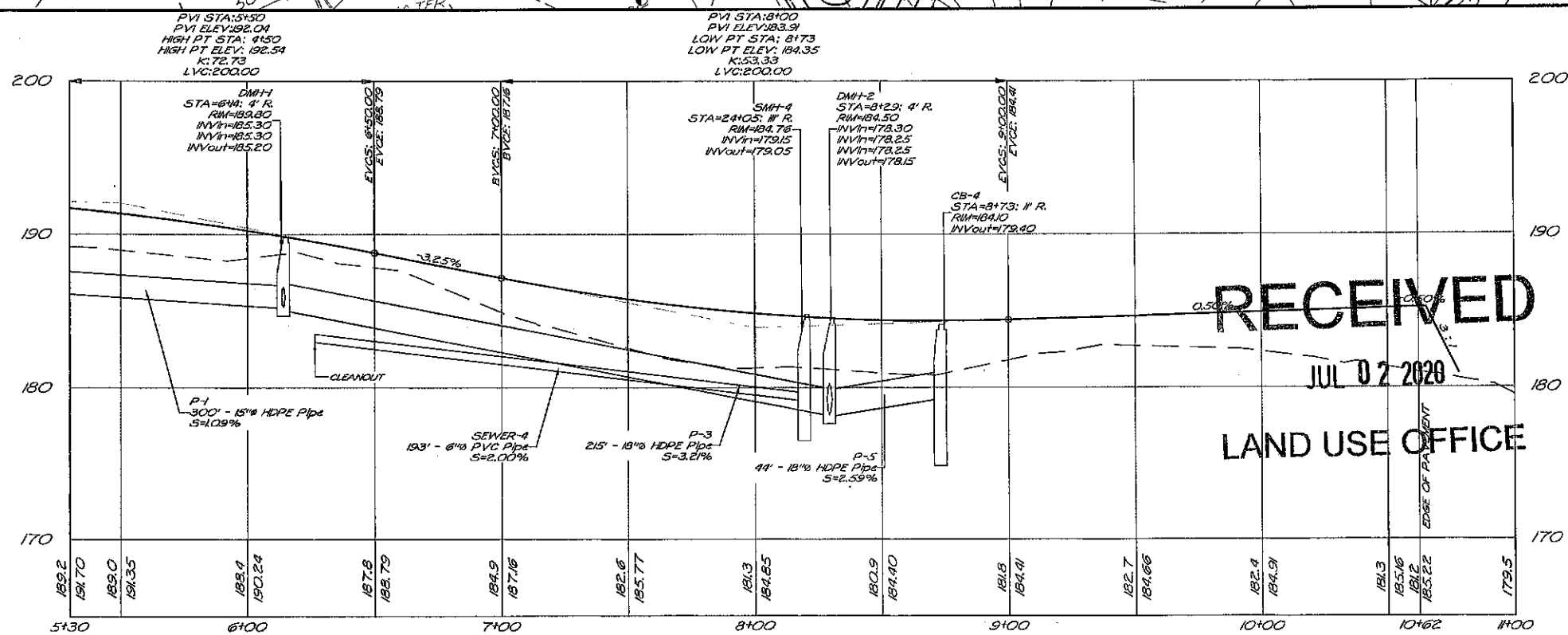

RECEIVED
 JUL 02 2020
 LAND USE OFFICE

TRITECH
 ENGINEERING CORPORATION

REVISIONS	DATE	DESCRIPTION
1	5/29/20	GENERAL REVISIONS
2	6/30/20	REVISION PER PEER REVIEW

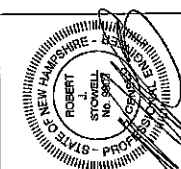

ROADWAY PLAN AND PROFILE
BARRINGTON STORAGE-OFFICE
 ROUTE #125
 BARRINGTON, NEW HAMPSHIRE
 NOVEMBER 11, 2019 JOB No. 19107
 SCALE: 1" = 30'

SHEET No.



785 CENTRAL AVENUE
 COVINA, NEW HAMPSHIRE 06030
 TELEPHONE 603 742 8107
 FAX 603 742 3960

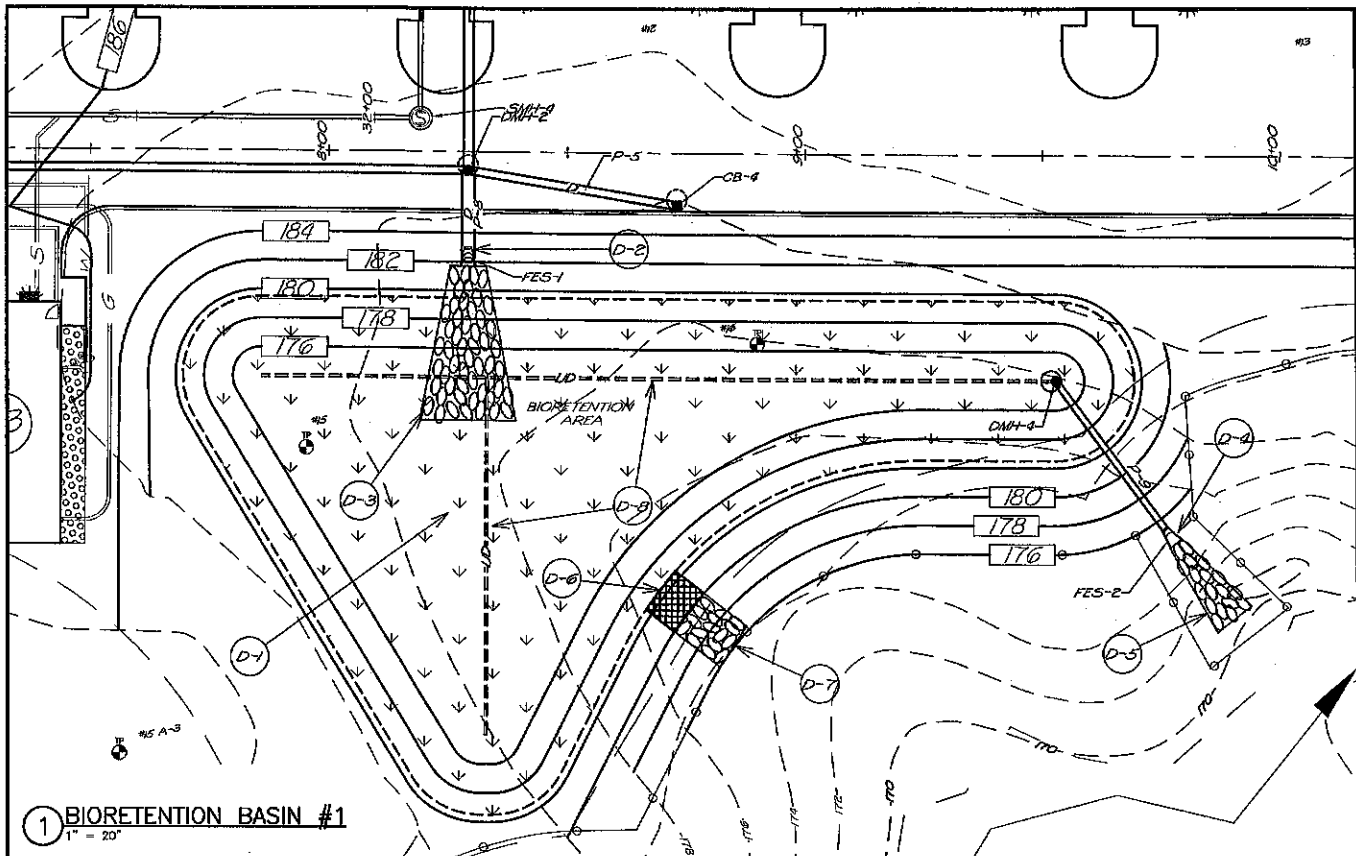

1 BIORETENTION BASIN #1
1" = 20'

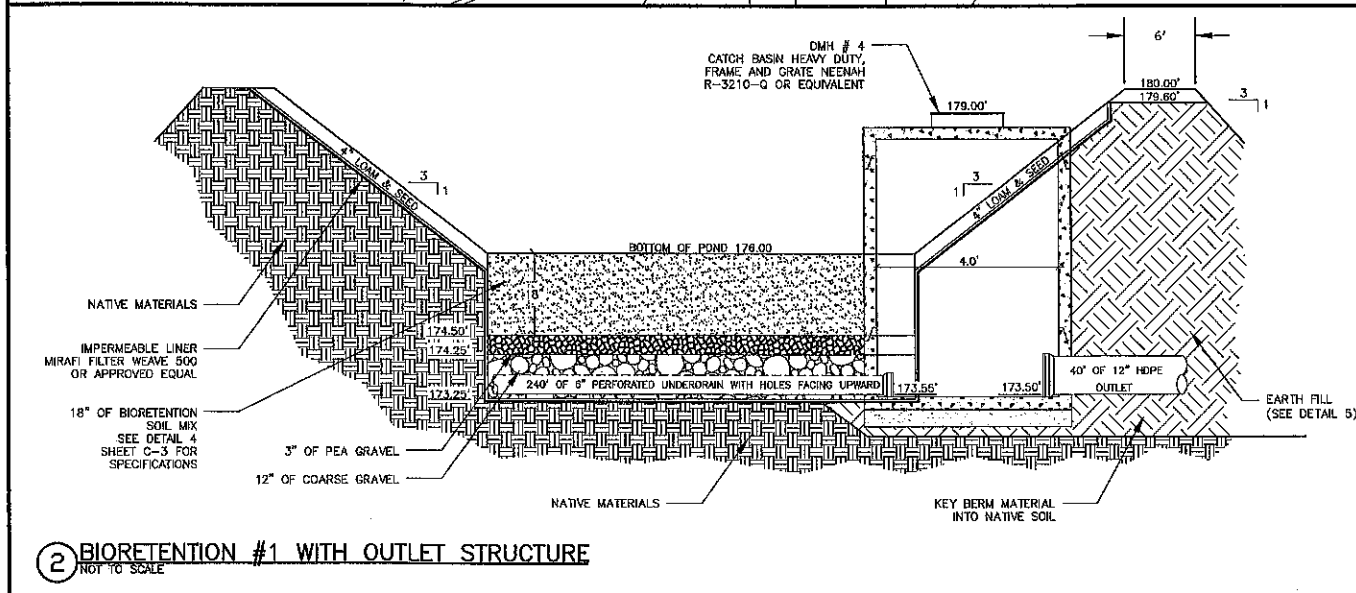

2 BIORETENTION #1 WITH OUTLET STRUCTURE
NOT TO SCALE

STRUCTURE	RIM ELEV.	INVERT IN	INVERT OUT	SUMP	HOODING
CB-1	183.00		188.60	184.60	HOODED
CB-2	183.60		185.40	181.60	HOODED
CB-3	183.60		185.00	181.00	HOODED
CB-4	184.00		179.40	175.40	HOODED
CB-5	184.00		179.55	175.55	HOODED
CB-6	182.65		188.95	185.95	
DMH-1	189.80	185.30 (P-2) 185.30 (P-1)	185.20		
DMH-2	184.50	178.30 (P-3) 178.25 (P-5) 178.25 (P-7)	178.15		
DMH-3	184.30	179.00 (P-6) 179.00 (P-4)	179.00		
DMH-4	179.00	173.55 (UD-1)	173.50		
FES-1		178.00 (P-8)			
FES-2		173.00 (P-9)			
FES-3		187.75 (P-10)			

PIPE	START	INV.	END	INV.	SIZE	L.F.	SLOPE
P-1	CB-1	188.60	DMH-1	185.30	15"	300'	1.09%
P-2	CB-2	185.40	DMH-1	185.30	15"	7'	1.39%
P-3	DMH-1	185.20	DMH-2	178.30	18"	215'	3.27%
P-4	CB-3	185.00	DMH-3	179.00	18"	215'	2.79%
P-5	CB-4	179.40	DMH-2	178.25	18"	44'	2.59%
P-6	CB-5	179.55	DMH-3	179.00	18"	44'	1.03%
P-7	DMH-3	179.00	DMH-2	178.25	24"	128'	0.59%
P-8	DMH-2	178.15	FES-1	178.00	30"	18'	0.82%
P-9	DMH-4	173.50	FES-2	173.00	15"	40'	1.24%
P-10	CB-6	188.95	FES-3	187.75	18"	80'	1.50%
UD-1		173.55	DMH-4	173.55	6"	240"	0.00%

NEW ENGLAND WETLAND PLANTS INC.
NEW ENGLAND EROSION CONTROL/RESTORATION MIX FOR DETENTION BASINS AND MOIST SITES

THE MIX MAY BE APPLIED BY HAND, BY MECHANICAL SPREADER, OR BY HYDRO-SEEDER. AFTER SOWING, LIGHTLY RAKE, ROLL, OR CULTIPACK TO INSURE GOOD SEED-TO-SOIL CONTACT. BEST RESULTS ARE OBTAINED WITH A SPRING OR LATE SUMMER SEEDING. LATE FALL AND WINTER DORMANT SEEDING REQUIRES AN INCREASE IN THE APPLICATION RATE. A LIGHT MULCHING OF CLEAN, WEED-FREE STRAW IS RECOMMENDED.

NEW ENGLAND WETLAND PLANTS INC.
NEW ENGLAND EROSION CONTROL/RESTORATION MIX FOR DRY SITES

THE NEW ENGLAND EROSION CONTROL/RESTORATION MIX FOR DRY SITES MAY BE APPLIED BY HYDRO SEEDING, BY MECHANICAL SPREADER, OR ON SMALL SITES IT CAN BE SPREAD BY HAND, LIGHTLY RAKE, OR ROLL TO ENSURE PROPER SOIL-SEED CONTACT. BEST RESULTS ARE OBTAINED WITH A SPRING OR LATE SUMMER SEEDING. LATE SPRING THROUGH MID-SUMMER SEEDING WILL BENEFIT FROM A LIGHT MULCHING OF WEED-FREE STRAW TO CONSERVE MOISTURE. IF CONDITIONS ARE DRIER THAN USUAL, WATERING WILL BE REQUIRED. FERTILIZATION IS NOT REQUIRED UNLESS THE SOILS ARE PARTICULARLY INFERTILE. PREPARATION OF A CLEAN WEED FREE SEED BASE IS NECESSARY FOR OPTIMAL RESULTS.

ANYWHERE ON THE SITE THAT EXISTING VEGETATION IS TO BE REMOVED WILL REQUIRE IMMEDIATE EROSION CONTROL TREATMENT. SPECIAL CARE SHOULD BE TAKEN WHERE RUNOFF ENTERS WETLANDS. ALL STORM WATER AREAS SHALL BE STABILIZED PRIOR TO DIRECTING STORM WATER TO THEM; SPECIFICALLY ALL BIORETENTION BASINS AND ALL INFILTRATION AREAS.

SEEDING LEGEND

- 50/50 BLEND OF NEW ENGLAND EROSION CONTROL/RESTORATION MIX FOR DRY SITES AND NEW ENGLAND EROSION CONTROL/RESTORATION MIX FOR DETENTION BASINS AND MOIST SITES.
- BOTH MIXES FROM NEW ENGLAND WETLAND PLANTS INC. APPLY: 35 LBS/ACRE : 1250 SQ FT/LB
- LIMITS OF BIORETENTION SOIL MIX

3 BIORETENTION SEEDING
NOT TO SCALE

- PARTICLE SIZE DISTRIBUTION BY SEPARATES:
 - EXCLUDE ANY MATERIAL >4.75mm - 0%
 - VERY COARSE SAND/GRAVEL: GRAVEL (2.0 TO 4.75 mm) 5% MAXIMUM (% BY DRY WEIGHT)
 - SAND (0.42 TO 2.0 mm) 50 - 85% (% BY DRY WEIGHT)
 - SILT (0.075 TO 0.42 mm) 20% MAXIMUM (% BY DRY WEIGHT)
 - CLAY (LESS THAN 0.075mm) 5% MAXIMUM (% BY DRY WEIGHT)

ACCEPTABLE PARTICLE SIZE DISTRIBUTION OF FINAL BIORETENTION SOIL MIX

SEIVE	% PASSING
#4	100
#10	95
#40	40 - 15
#200	10 - 20
<#200	0 - 5

- FRAGMENT SIZE DISTRIBUTION:
 - STICKS AND ROOTS: SHOULD BE MINIMIZED AND PREFERABLY LIMITED TO NOTHING LARGER THAN 4.75mm
 - DEBRIS AND OTHER FOREIGN MATERIALS: SHOULD BE MINIMIZED
- PERCENTAGE ORGANIC MATTER: MINIMUM 3% BY VOLUME AND MAXIMUM 8% BY VOLUME
- SOIL REACTION: pH OF 6 TO 7
- CEC OF TOTAL SOIL: MINIMUM 10 meq/100mL AT pH OF 7.0
- BASIS-OF-DESIGN PRODUCT: SUBJECT TO COMPLIANCE WITH REQUIREMENTS INDICATED ON DRAWINGS
- BASIC PROPERTIES: MANUFACTURED SOIL SHALL NOT CONTAIN THE FOLLOWING:
 - UNACCEPTABLE MATERIALS: CONCRETE SLURRY, CONCRETE LAYERS OR CHUNKS, CEMENT, PLASTER, BUILDING DEBRIS, ASPHALT, BRICKS, OILS, GASOLINE, DIESEL FUEL, PAINT THINNER, TURPENTINE, TAR, ROOFING COMPOUND, ACID, SOLID WASTE, AND OTHER EXTRANEOUS MATERIALS THAT ARE HARMFUL TO PLANT GROWTH.
 - UNSUITABLE MATERIALS: STONES, ROOTS, PLANTS, SOIL, CLAY LUMPS, AND POCKETS OF COARSE SAND THAT EXCEED A COMBINED MAXIMUM OF 5% BY DRY WEIGHT OF THE MANUFACTURED SOIL.
 - LARGE MATERIALS: STONES, CLODS, ROOTS, CLAY LUMPS, AND POCKETS OF COARSE SAND EXCEEDING 0.187 INCHES (4.76mm) IN ANY DIMENSION

4 BIORETENTION SOIL MIX
NOT TO SCALE

FILL MATERIAL SHOULD BE TAKEN FROM AN APPROVED, DESIGNATED BORROW AREA. IT SHOULD BE FREE OF ROOTS, STUMPS, WOOD, RUBBISH, STONES GREATER THAN 6 INCHES, AND FROZEN OR OTHER OBJECTIONABLE MATERIALS.

AREAS ON WHICH FILL IS TO BE PLACED SHOULD BE SCARIFIED BEFORE PLACEMENT. FILL MATERIAL SHOULD BE PLACED IN LAYERS A MAXIMUM OF 8 INCHES THICK (BEFORE COMPACTION), WHICH SHOULD BE CONTINUOUS OVER THE ENTIRE LENGTH OF THE FILL.

FILL MATERIAL SHOULD BE COMPACTED WITH APPROPRIATE COMPACTION EQUIPMENT SUCH AS SHEEPSFOOT, RUBBER-TIRED, OR VIBRATORY ROLLER.

A MINIMUM REQUIRED DENSITY IS 95% OF MAXIMUM DRY DENSITY WITH A MOISTURE CONTENT WITHIN 2% OF THE OPTIMUM. EACH LAYER OF THE FILL SHOULD BE COMPACTED AS NECESSARY TO OBTAIN MINIMUM DENSITY.

5 EARTH FILL
NOT TO SCALE

D-1 DRAINAGE NOTES

- INSTALL BIORETENTION BASIN AREA #1.
- INSTALL FES 1 @ ELEV = 178.00. SEE DETAIL 12, SHEET SP-7.
- INSTALL RIP-RAP PER DETAIL 8, SHEET SP-7
WO=7.5', WE=20', LA=32', D=12', D50=6".
- INSTALL FES 2 @ ELEV = 173.00. SEE DETAIL 12, SHEET SP-7.
- INSTALL RIP-RAP PER DETAIL 8, SHEET SP-7
WO=3.6', WE=10', LA=20', D=8", D50=3".
- CONSTRUCT 10' WIDE SPILLWAY IN BERM @ ELEVATION 179.00'.
- INSTALL RIP-RAP PER DETAIL 8, SHEET SP-7
Wo=10', We=10', La=10', D=8", D50=3".
- INSTALL PERFORATED UNDERDRAIN PER DETAIL 9. NOT USED
- INSTALL FES 3 @ ELEV = 187.75. SEE DETAIL 12, SHEET SP-7.
- INSTALL RIP-RAP PER DETAIL 8, SHEET SP-7
WO=4.5', WE=12.5', LA=20', D=6", D50=3".

TRITECH
ENGINEERING CORPORATION

285 CENTRAL AVENUE
DOVER, NEW HAMPSHIRE 03860
TELEPHONE 603 742 8177
FAX 603 742 8600

REVISIONS	DATE	DESCRIPTION
	12/22/19	ADDED TO PLAN SET
	5/29/20	GENERAL REVISIONS
	6/30/20	REVISED PER PEER REVIEW

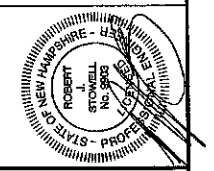

BIORETENTION PLAN AND DETAILS
BARRINGTON STORAGE-OFFICE
ROUTE #125
BARRINGTON, NEW HAMPSHIRE
NOVEMBER 11, 2019 JOB No. 19107
SCALE: 1" = 30'

RECEIVED
JUL 02 2020
LAND USE OFFICE

SHEET No.

0-8

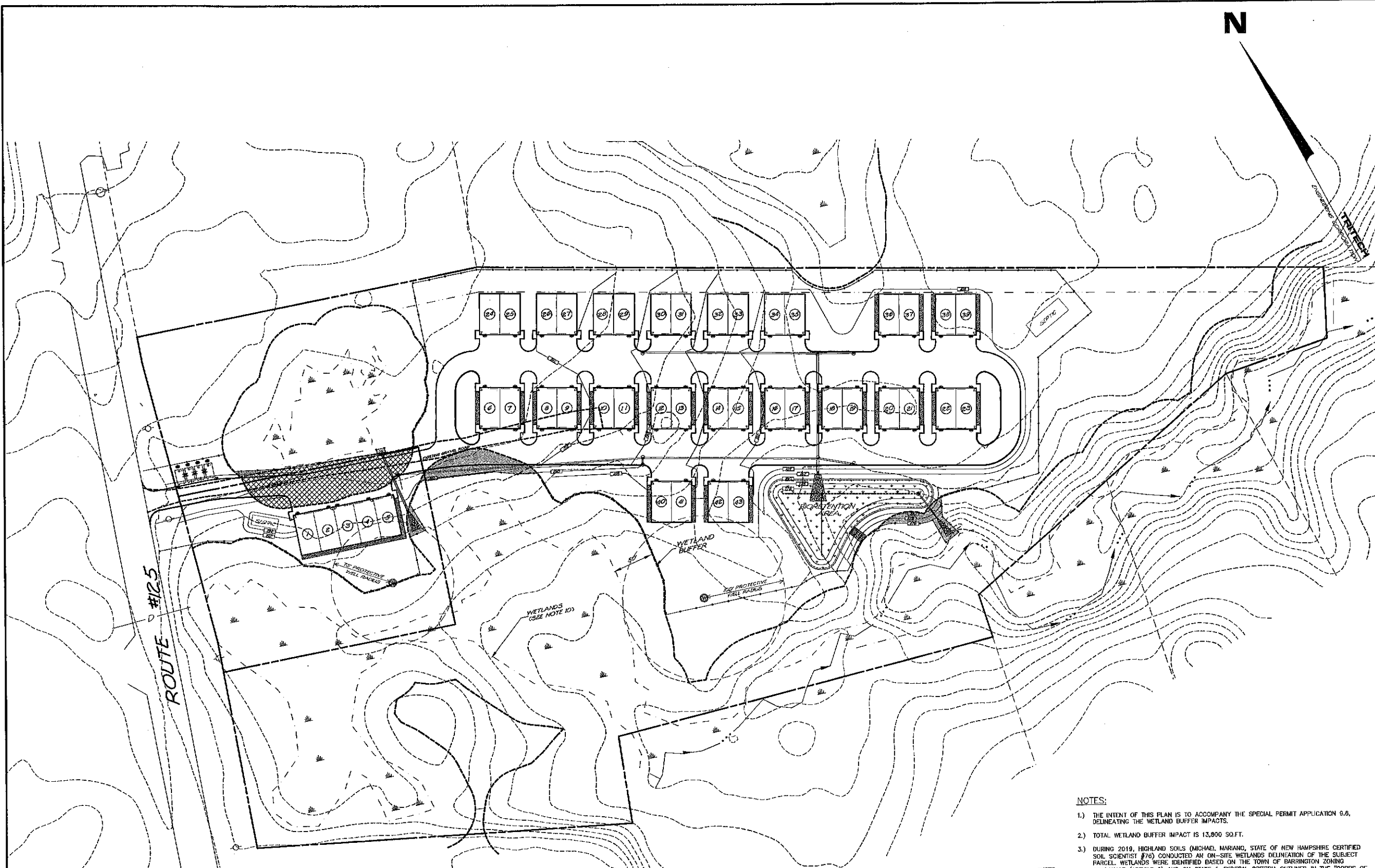

N

ROUTE #125

TRITECH
ENGINEERING CORPORATION

TRITECH
ENGINEERING CORPORATION
788 CENTRAL AVENUE
DOVER, NEW HAMPSHIRE 03860
TELEPHONE 603 742 8107
FAX 603 742 9660

REVISIONS	DATE	DESCRIPTION
	12/2/19	ADDED TO PLAN SET
	5/29/20	REVISED DISTURANCE
	9/30/20	REVISED PER PEER REVIEW



SPECIAL PERMIT PLAN
BARRINGTON STORAGE-OFFICE
ROUTE #125
BARRINGTON, NEW HAMPSHIRE
NOVEMBER 11, 2019 JOB No. 19107
SCALE: 1" = 60'

SHEET No. **SPP-1**

RECEIVED

JUL 02 2020

LAND USE OFFICE

-  EXISTING DEVELOPED BUFFER (8,500 SQ.FT.)
-  NEW DISTURBANCE (5,300 SQ.FT.)
- IMPERVIOUS = 1,500 SQ.FT.
- PERVIOUS = 3,800 SQ.FT.

NOTES:

- 1.) THE INTENT OF THIS PLAN IS TO ACCOMPANY THE SPECIAL PERMIT APPLICATION 9.6, DELINEATING THE WETLAND BUFFER IMPACTS.
- 2.) TOTAL WETLAND BUFFER IMPACT IS 13,800 SQ.FT.
- 3.) DURING 2019, HIGHLAND SOILS (MICHAEL MARIANO, STATE OF NEW HAMPSHIRE CERTIFIED SOIL SCIENTIST #716) CONDUCTED AN ON-SITE WETLANDS DELINEATION OF THE SUBJECT PARCEL. WETLANDS WERE IDENTIFIED BASED ON THE TOWN OF BARRINGTON ZONING ORDINANCE (ARTICLE 9) AND ON STATE & FEDERAL CRITERIA OUTLINED IN THE "CORPS OF ENGINEERS WETLANDS DELINEATION MANUAL" (DEPT. OF THE ARMY, 1987). ON THIS SITE, WETLANDS BASED ON LOCAL CRITERIA SHARE THE SAME BOUNDARIES WITH THOSE BASED ON STATE AND FEDERAL CRITERIA.

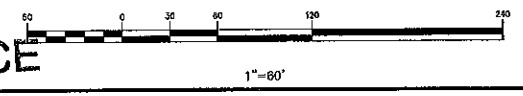

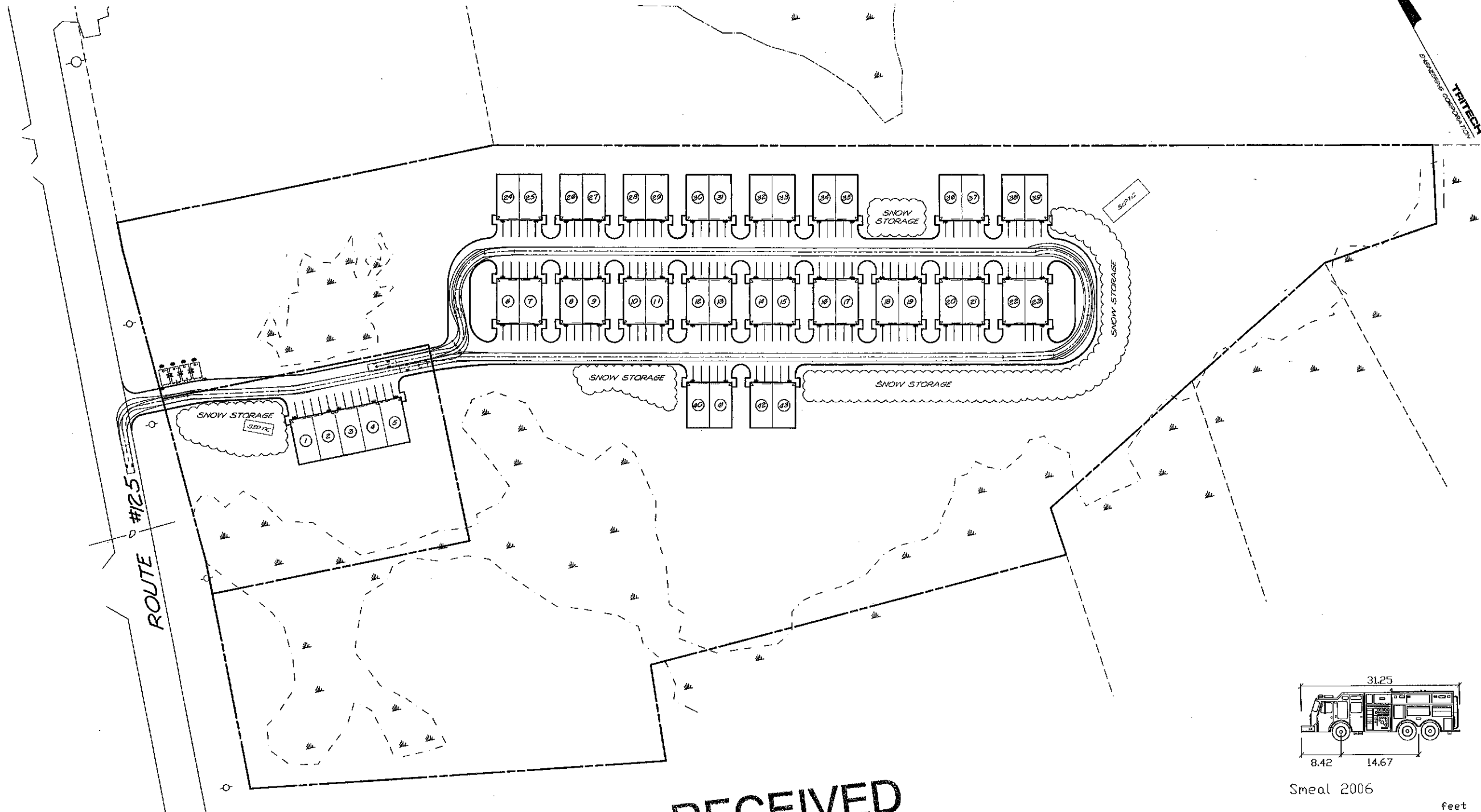

TRITECH
ENGINEERING CORPORATION

TRITECH
ENGINEERING CORPORATION
788 CENTRAL AVENUE
DOVER, NEW HAMPSHIRE 03860
TELEPHONE 603 742 8107
FAX 603 742 8283

REVISIONS	DATE	DESCRIPTION
	12/2/18	ADDED TO PLAN SET
	5/28/20	GENERAL REVISIONS
	6/30/20	REVISED PER PEER REVIEW

TRAFFIC CIRCULATION PLAN
BARRINGTON STORAGE-OFFICE
ROUTE #125
BARRINGTON, NEW HAMPSHIRE
NOVEMBER 11, 2019 JOB No. 19107
SCALE: 1" = 60'

RECEIVED
JUL 02 2020
LAND USE OFFICE

PARKING REQUIREMENTS OUTLINED IN SECTION 4.9.
REQUIRED PARKING SPACES PER EACH UNIT
250 SQ.FT. OFFICE 1 PER 300 = 1 SPACE
1,000 SQ.FT. WAREHOUSE 1 PER 1000 = 1 SPACE
TOTAL REQUIRED PARKING SPACES PER UNIT = 2 SPACES
MINIMUM PARKING SPACES PROVIDED PER UNIT = 2 SPACES
(UNSTRIPED)

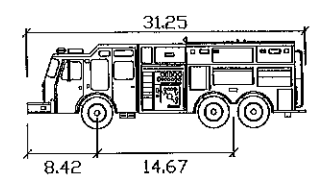

Smeal 2006

	feet
Width	8.50
Track	8.50
Lock to Lock Time	6.0
Steering Angle	37.8

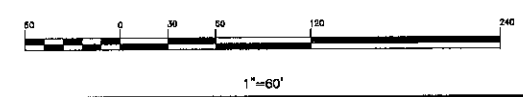

SHEET No.

CIR-1

StatArea_1
 DRIVE AREAS
 Illuminance (Fc)
 Average = 0.75
 Maximum = 8.5
 Minimum = 0.0
 Avg/Mln Ratio = N.A.
 Max/Mln Ratio = N.A.

Luminaire Schedule				
Symbol	Qty	Label	Arrangement	Description
W	61	W1	SINGLE	MERU-LED-AC-DB PIR / WALL MTD 10' AFG

LIGHTING NOTES

1. INSTALL (81) 17 WATT MERU WALL MOUNTED LED LIGHT FIXTURES, MERU-LED-AC-DB PIR, MOUNTED 10' ABOVE FINISHED GRADE, WITH SHIELDING.
2. EXTERIOR LIGHTING SHALL BE DOWN LIT AND FULLY SHIELDED SO NO DIRECT LIGHT IS VISIBLE FROM ADJACENT PROPERTIES AND ROADWAYS.
3. ALL PARKING AREA LIGHTING SHALL BE EQUIPPED WITH A TIMER AND SHALL SHUT OFF NO LATER THAN 10 PM EACH DAY AND REMAIN OFF UNTIL THE FOLLOWING EVENING. IN THE EVENT THAT THE BUSINESS REMAINS OPEN AFTER 10 PM, THE PARKING LOT LIGHTING SHALL SHUT OFF NO LATER THAN ONE HOUR AFTER CLOSING.
4. PHOTOMETRICS CONTAINED ON THIS PLAN PROVIDED BY CHARRON INC.



TRITECH
 ENGINEERING CORPORATION

705 CENTRAL AVENUE
 DOWRY NEW HAMPSHIRE 03820
 TELEPHONE 603 748 8107
 FAX 603 748 3850

REVISIONS	DATE	DESCRIPTION
	5/29/20	ADDED TO PLAN SET

BARRINGTON STORAGE-OFFICE
 ROUTE #125
 BARRINGTON, NEW HAMPSHIRE
 NOVEMBER 11, 2019 JOB No. 19107
 SCALE: 1" = 30'

SHEET No.



1"=30'

RECEIVED

NOV 02 2020

OFFICE

ROUTE #125

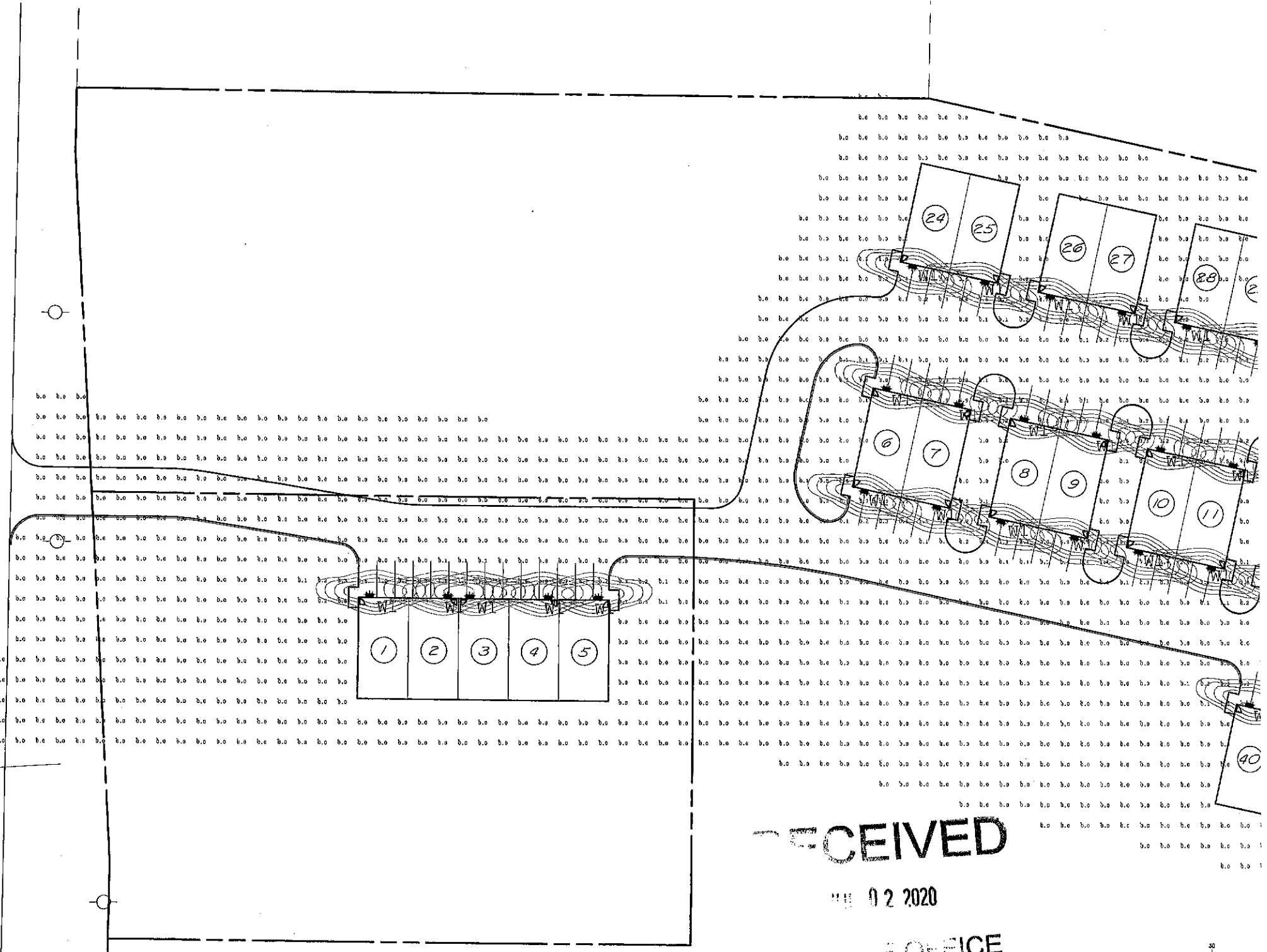

StatArea_1
 DRIVE AREAS
 Illuminance (Fc)
 Average = 0.75
 Maximum = 8.5
 Minimum = 0.0
 Avg/Min Ratio = N.A.
 Max/Min Ratio = N.A.

Luminaire Schedule				
Symbol	Qty	Label	Arrangement	Description
W	61	W	SINGLE	MERU-LED-AC-DB PIR / WALL MTD 10' AFG

LIGHTING NOTES

1. INSTALL (61) 17 WATT MERU WALL MOUNTED LED LIGHT FIXTURES, MERU-LED-AC-DB PIR, MOUNTED 10' ABOVE FINISHED GRADE, WITH SHIELDING.
2. EXTERIOR LIGHTING SHALL BE DOWN LIT AND FULLY SHIELDED SO NO DIRECT LIGHT IS VISIBLE FROM ADJACENT PROPERTIES AND ROADWAYS.
3. ALL PARKING AREA LIGHTING SHALL BE EQUIPPED WITH A TIMER AND SHALL SHUT OFF NO LATER THAN 10 PM EACH DAY AND REMAIN OFF UNTIL THE FOLLOWING EVENING. IN THE EVENT THAT THE BUSINESS REMAINS OPEN AFTER 10 PM, THE PARKING LOT LIGHTING SHALL SHUT OFF NO LATER THAN ONE HOUR AFTER CLOSING.
4. PHOTOMETRICS CONTAINED ON THIS PLAN PROVIDED BY CHARRON INC.

N

TRITECH
 ENGINEERING CORPORATION

TRITECH
 ENGINEERING CORPORATION

785 CORTLAND AVENUE
 DUBLIN, NEW HAMPSHIRE 03028
 TELEPHONE 603 742 8107
 FAX 603 742 3830

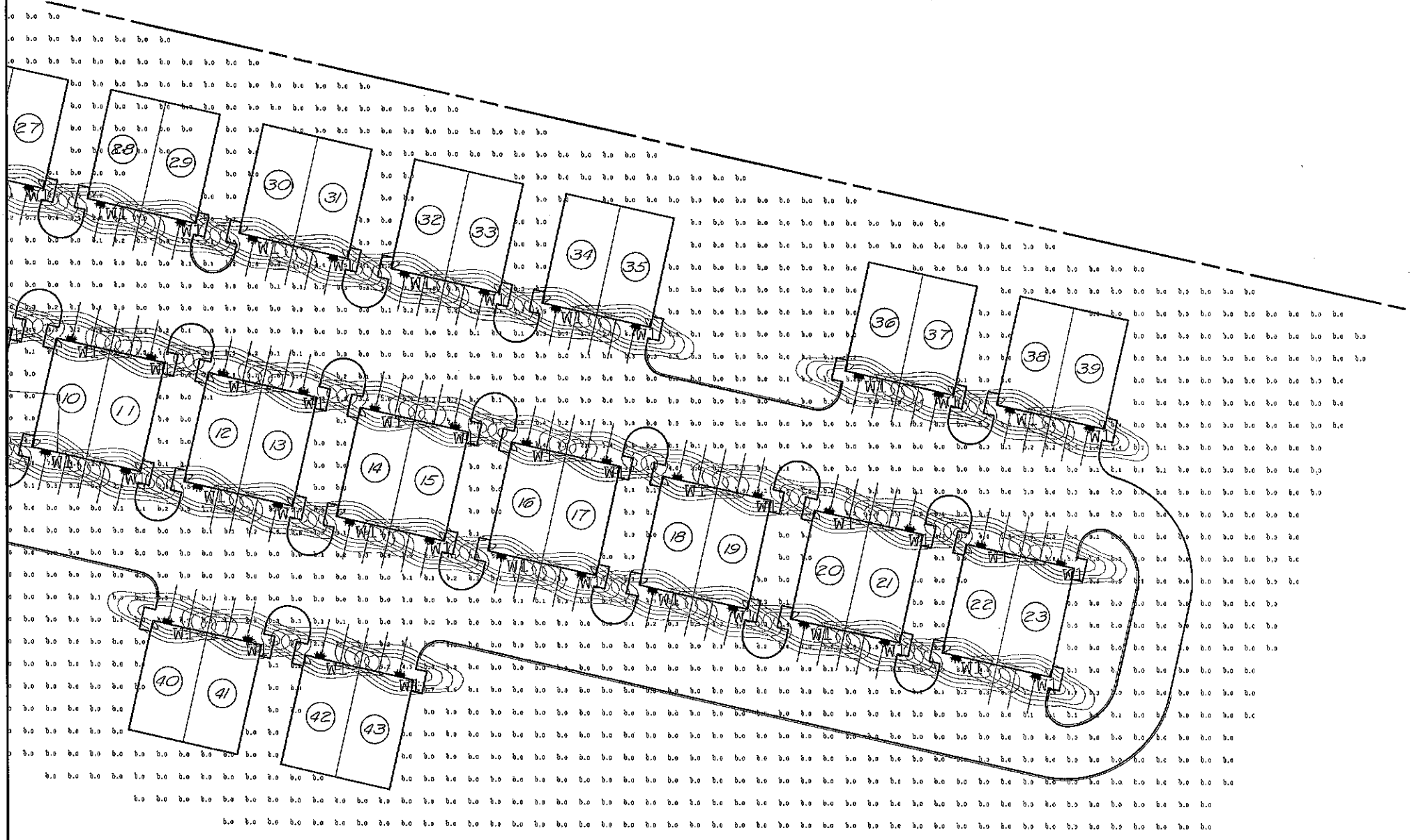

REVISIONS	DATE	DESCRIPTION
	5/29/20	ADDED TO PLAN SET
	6/30/20	REVISED PER PEER REVIEW

LIGHTING PLAN
BARRINGTON STORAGE-OFFICE
 ROUTE #125
 BARRINGTON, NEW HAMPSHIRE
 NOVEMBER 11, 2019 JOB No. 19107
 SCALE: 1" = 30'

RECEIVED
 JUL 02 2020
 LAND USE OFFICE

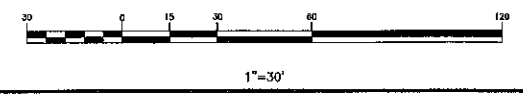

SHEET No.

Li-1A

N

TRITECH
ENGINEERING CORPORATION

TRITECH
ENGINEERING CORPORATION

788 CENTRAL AVENUE
DOVER NEW HAMPSHIRE 03801
TELEPHONE 603 742 8107
FAX 603 742 3890

REVISIONS DATE	DESCRIPTION
6/30/20	ADDED TO PLAN SET

LANDSCAPE PLAN
BARRINGTON STORAGE-OFFICE
 ROUTE #125
 BARRINGTON, NEW HAMPSHIRE
 NOVEMBER 14, 2019 JOB No. 19107
 SCALE: 1" = 30'

SHEET No.

LA-1

ROUTE #125

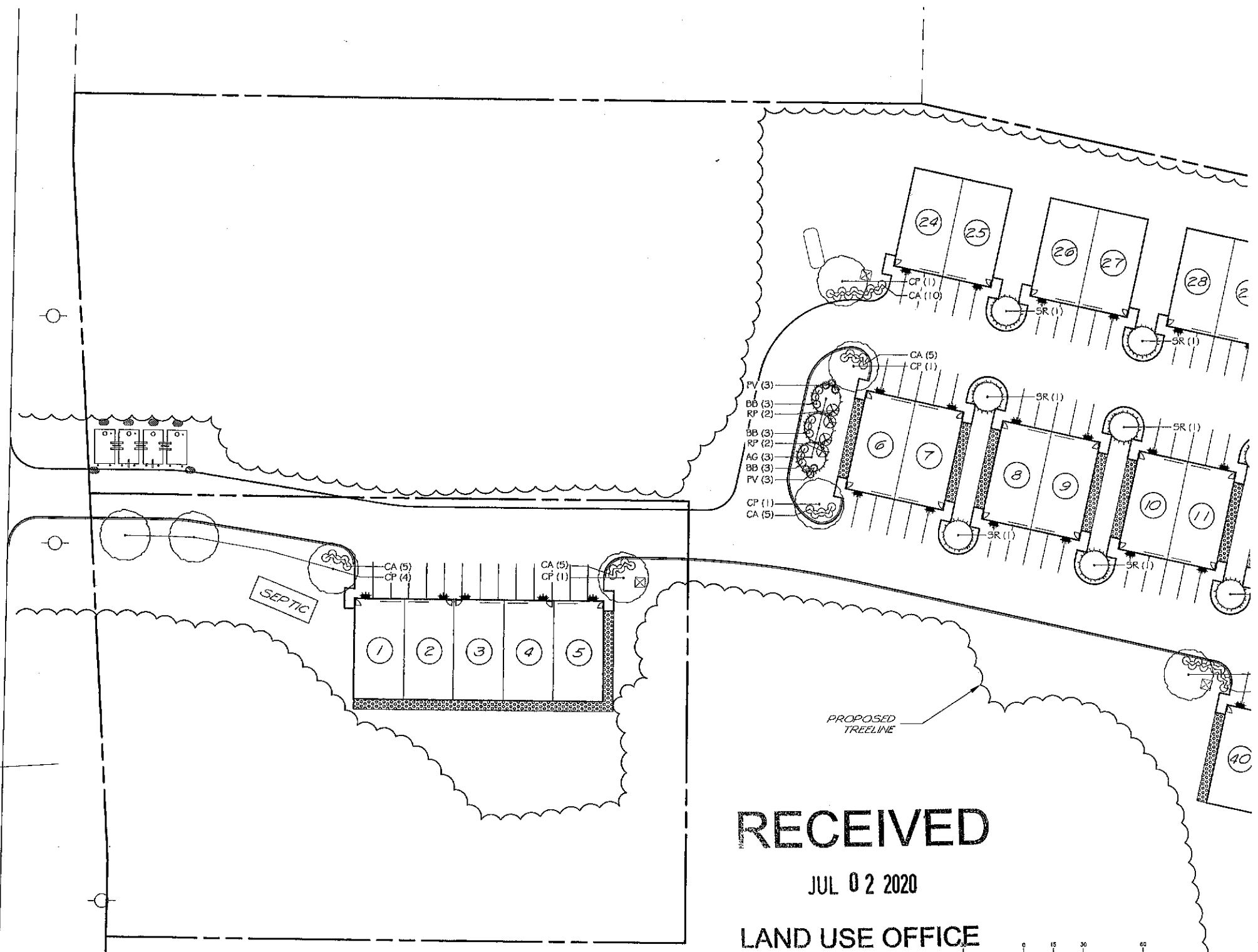

RECEIVED

JUL 02 2020

LAND USE OFFICE

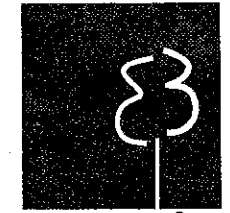

terrain
planning & design llc

311 kast hill road
hopkinton nh 03229
603. 491. 2322
terrainplanning.com

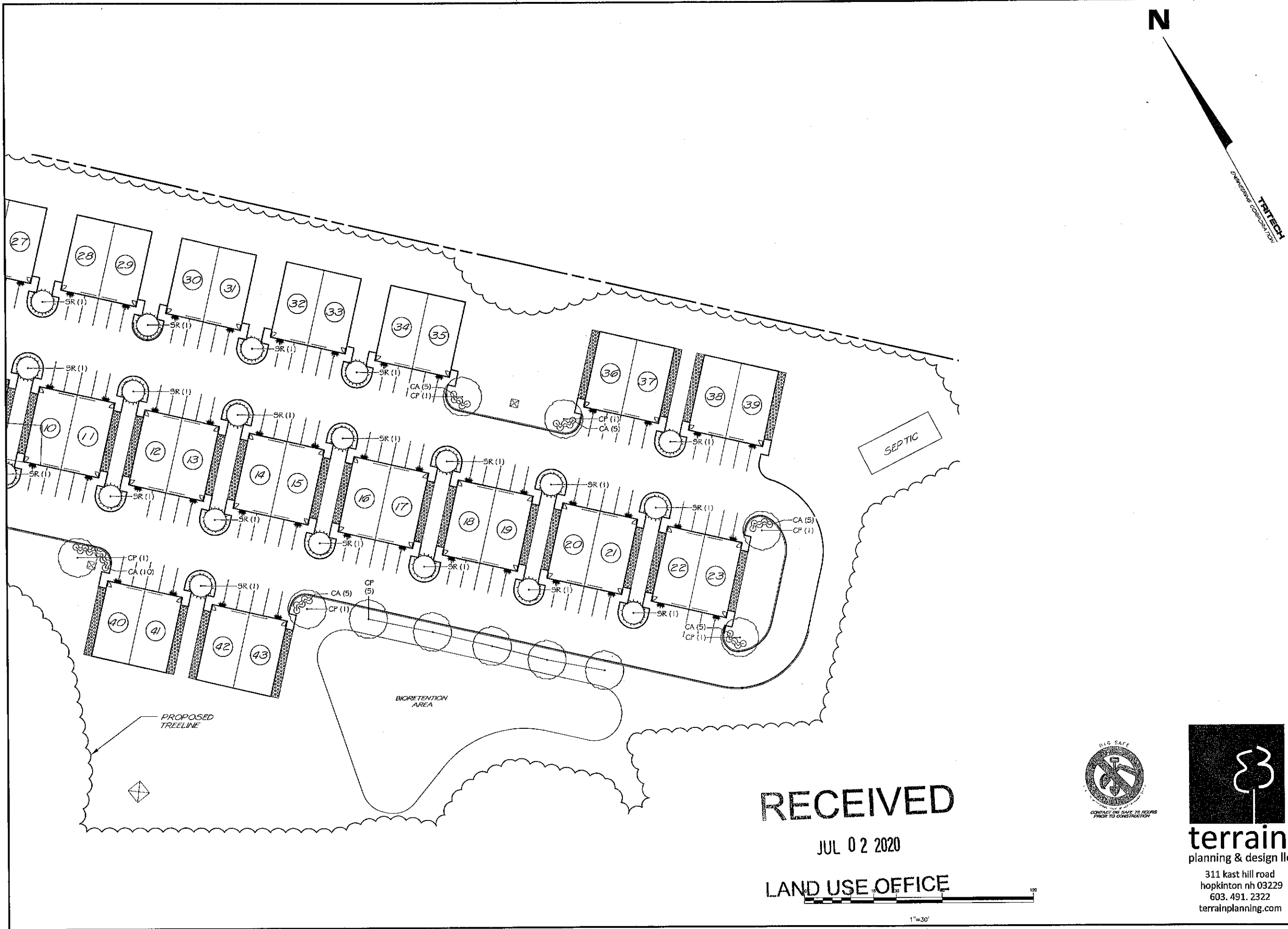

TRITECH
ENGINEERING CORPORATION

788 CENTRAL AVENUE
COVING NEW HAMPSHIRE 03303
TELEPHONE 603 742 8707
FAX 603 742 9980

REVISIONS	DATE	DESCRIPTION
	6/30/20	ADDED TO PLAN SET

LANDSCAPE PLAN

BARRINGTON STORAGE-OFFICE

ROUTE #125
BARRINGTON, NEW HAMPSHIRE
NOVEMBER 14, 2019 JOB No. 19107
SCALE: 1" = 30'

SHEET No.

LA-1A

RECEIVED

JUL 02 2020

LAND USE OFFICE



1"=30'

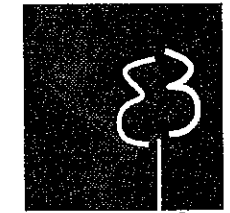

terrain
planning & design llc

311 kast hill road
hopkinton nh 03229
603. 491. 2322
terrainplanning.com

GENERAL NOTES:

1. BASE PLAN DEVELOPED FROM INFORMATION PROVIDED BY TRITECH ENGINEERING.
2. VERIFY LOCATIONS, ELEVATIONS, AND DIMENSIONS IN THE FIELD, PRIOR TO CONSTRUCTION. VERIFY FIELD CONDITIONS RELATING TO WORK TO BE INSTALLED. NOTIFY LANDSCAPE ARCHITECT OF ANY UNUSUAL OR DIFFICULT CONDITIONS IN A TIMELY MANNER PRIOR TO CONSTRUCTION CONCERNING THE CONDITION IN QUESTION.
3. ALL WORK SHALL CONFORM TO THE REQUIREMENTS OF THE TOWN OF BARRINGTON AND STATE OF NEW HAMPSHIRE. NOTIFY APPROPRIATE AGENCIES AT LEAST 48 HOURS PRIOR TO PERFORMING THE WORK UNDER THEIR JURISDICTION.
4. CONTRACTOR IS RESPONSIBLE FOR SECURING AND PAYING FOR ALL CONSTRUCTION PERMITS AND LICENSES REQUIRED TO COMPLETE SITE WORK. CONTRACTOR IS RESPONSIBLE FOR ALL APPROPRIATE INSPECTIONS OF HISHER WORK.
5. ALL WORK SHALL BE OF WORKMANLIKE QUALITY AND IN CONFORMANCE WITH ALL APPLICABLE CODES. CONTRACTOR SHALL READ ALL ZONING AND ENVIRONMENTAL PERMITS WHICH PERTAIN TO THE PROJECT AND SHALL COMPLY WITH ALL THE CONDITIONS THEREIN.
6. NOTIFY LANDSCAPE ARCHITECT AT LEAST 72 HOURS PRIOR TO ANY ROUTINE REQUIRED FIELD OBSERVATION. OBTAIN LANDSCAPE ARCHITECT'S APPROVAL OF THE LAYOUT OF ALL IMPROVEMENTS PRIOR TO CONSTRUCTION.
7. CONTRACTOR IS RESPONSIBLE FOR REPAIR OF DAMAGE OR DISTURBANCE TO OTHER AREAS WHICH MAY OCCUR AS THE RESULT OF HISHER WORK WHETHER WITHIN OR OUTSIDE OF THE CONTRACT LIMIT LINES.
8. CONSTRUCTION SHALL FOLLOW THE SEQUENCES AND CONDITIONS ESTABLISHED IN THE SPECIFICATIONS AND PERMITS.
9. IT IS INTENDED THAT THE WORK BE EXECUTED IN ACCORDANCE WITH THE BEST CUSTOMARY BUILDING PRACTICES. IF WORK IS REQUIRED IN A MANNER THAT IS IMPOSSIBLE TO PRODUCE FIRST-CLASS WORK OR IF ERRORS, CONFLICTS OR DISCREPANCIES APPEAR AMONG THE CONTRACT DOCUMENTS, INFORM THE LANDSCAPE ARCHITECT IMMEDIATELY AND REQUEST INTERPRETATION BEFORE PROCEEDING WITH THE WORK.
10. IF CONTRACTOR FAILS TO MAKE SUCH A STATEMENT AND REQUEST, NO EXCUSE WILL THEREAFTER BE ENTERTAINED, NOR ADDITIONAL DEFENSE BE ACCEPTED, FOR FAILURE TO CARRY OUT WORK IN A SATISFACTORY MANNER. SHOULD CONFLICT OCCUR IN OR BETWEEN DRAWINGS AND SPECIFICATIONS, CONTRACTOR IS DEEMED TO HAVE ESTIMATED ON THE MORE EXPENSIVE WAY OF DOING WORK UNLESS HIS/HE SHE SHALL HAVE OBTAINED A WRITTEN DECISION, BEFORE SUBMITTING HIS BID, AS TO WHICH METHOD OR MATERIALS WILL BE REQUIRED.
11. CONTRACTOR IS RESPONSIBLE FOR ALL MATERIALS AND EQUIPMENT STORED AT SITE.
12. EROSION AND SEDIMENTATION CONTROL DEVICES SHALL BE IN PLACE PRIOR TO THE COMMENCEMENT OF ANY WORK.
13. ANY DISCREPANCIES SHALL BE REPORTED IMMEDIATELY TO THE LANDSCAPE ARCHITECT FOR DIRECTION AND RESOLUTION PRIOR TO ANY FURTHER WORK.
14. VISIBLE EXISTING CONDITIONS WHERE FIELD LOCATED, AND UNDERGROUND UTILITY LOCATIONS ARE APPROXIMATE. SITE SUBCONTRACTOR SHALL VERIFY ALL UTILITY LOCATIONS, DIMENSIONS, AND GRADES. PRIOR TO START OF ANY FOUNDATION OR UTILITY WORK.
15. WRITTEN DIMENSIONS HAVE PRECEDENCE OVER SCALED DIMENSIONS. THE CONTRACTOR SHALL USE CAUTION WHEN SCALING REPRODUCED PLANS. IN CASE OF CONFLICT BETWEEN THIS PLAN SET AND ANY OTHER DRAWING AND/OR SPECIFICATION, THE LANDSCAPE ARCHITECT SHALL BE NOTIFIED IMMEDIATELY FOR CLARIFICATIONS.
16. THE CONTRACTOR IS RESPONSIBLE FOR THE MEANS AND METHODS OF CONSTRUCTION AND FOR CONDITIONS AT THE SITE. THESE PLANS, PREPARED BY TERRAIN PLANNING & DESIGN LLC, DO NOT EXTEND TO OR INCLUDE SYSTEMS PERTAINING TO THE SAFETY OF THE CONSTRUCTION CONTRACTOR OR THEIR EMPLOYEES, AGENTS OR REPRESENTATIVES IN THE PERFORMANCE OF THE WORK. THE SEAL OF THE SURVEYOR, ENGINEER OR LANDSCAPE ARCHITECT HEREON DOES NOT EXTEND TO ANY SUCH SAFETY SYSTEMS THAT MAY NOW OR HEREAFTER BE INCORPORATED INTO THESE PLANS. THE CONSTRUCTION CONTRACTOR SHALL PREPARE OR OBTAIN THE APPROPRIATE SAFETY SYSTEMS WHICH MAY BE REQUIRED BY THE U.S. OCCUPATIONAL SAFETY AND HEALTH ADMINISTRATION (OSHA) AND/OR LOCAL REGULATIONS.
17. IT SHALL BE THE CONTRACTOR'S RESPONSIBILITY TO FAMILIARIZE HIMSELF WITH THE SITE AND ALL EXISTING CONDITIONS SURROUNDING IT AND THEREON. THE CONTRACTOR SHALL ADVISE THE APPROPRIATE AUTHORITY OF HIS INTENTIONS AT LEAST 48 HOURS IN ADVANCE.
18. THESE PLANS WERE PREPARED UNDER THE SUPERVISION OF A LICENSED PROFESSIONAL LANDSCAPE ARCHITECT. TERRAIN PLANNING & DESIGN LLC ASSUMES NO LIABILITY AS A RESULT OF ANY CHANGES OR NON-CONFORMANCE WITH THESE PLANS EXCEPT UPON THE WRITTEN APPROVAL OF THE LANDSCAPE ARCHITECT OF RECORD.
19. TERRAIN PLANNING & DESIGN LLC ASSUMES NO LIABILITY FOR WORK PERFORMED WITHOUT AN ACCEPTABLE PROGRAM OF TESTING AND INSPECTION AS APPROVED BY THE LANDSCAPE ARCHITECT OF RECORD.
20. BASE PREPARATION UNDER ALL HARD SURFACES TO BE COMPACTED TO 90% STANDARD PROCTOR DENSITY.
21. SITE CONTRACTOR IS RESPONSIBLE FOR CONTACTING DIG SAFE PRIOR TO ANY EXCAVATION. 1-888-DIG-SAFE.

PLANTING NOTES:

1. CONTRACTOR SHALL OBTAIN APPROVAL FROM LANDSCAPE ARCHITECT PRIOR TO PURCHASING AND/OR INSTALLING SUBSTITUTE PLANT MATERIAL PRIOR TO PURCHASE OF ANY SUBSTITUTE MATERIALS.
2. CONSTRUCTION ACCESS WILL BE AS DIRECTED BY LANDSCAPE ARCHITECT. CONTRACTOR IS RESPONSIBLE FOR RESTORATION OF ACCESS ROUTE AND ALL AREAS DISTURBED BY PLANTING OPERATIONS UPON COMPLETION OF CONSTRUCTION OPERATIONS, AT NO ADDITIONAL COST TO THE OWNER.
3. LAYOUT OF ALL PLANTING BEDS AND LOCATION OF PLANTS TO BE APPROVED BY LANDSCAPE ARCHITECT ON SITE PRIOR TO CONSTRUCTION AND INSTALLATION.
4. CONTRACTOR TO REMOVE ALL DEBRIS GENERATED BY PLANT INSTALLATION. DEBRIS TO BE DISPOSED OF IN A LEGAL MANNER.
5. ALL PLANT MATERIAL SHALL BE GUARANTEED TO BE IN GOOD, HEALTHY AND FLOURISHING CONDITION FOR ONE YEAR FROM THE DATE OF FINAL INSTALLATION APPROVAL BY LANDSCAPE ARCHITECT. CONTRACTOR SHALL REPLACE, WITHOUT COST TO OWNER, AND AS SOON AS WEATHER CONDITIONS PERMIT, ALL DEAD AND NON-FLOURISHING PLANTS AS DETERMINED BY THE LANDSCAPE ARCHITECT. REPLACEMENT PLANTS SHALL BE GUARANTEED IDENTICALLY TO ORIGINAL PLANTS, TIME PERIOD COMMENCING FROM DATE OF REPLACEMENT PLANTING APPROVAL BY LANDSCAPE ARCHITECT.
6. ALL BEDS TO BE MULCHED WITH 4" DEPTH SHREDDED BARK MULCH UNLESS NOTED OTHERWISE.
7. CONTRACTOR TO PROVIDE NECESSARY TEMPORARY IRRIGATION IF NEEDED BASED ON TIME OF YEAR THE PROJECT IS IMPLEMENTED.

LOAM & SEED ALL DISTURBED AREAS

PLANTING SCHEDULE				
Botanical Name / Common Name	Size	Label	Quantity	Mature Height
Trees				
<i>Amelanchier grandiflora</i> 'Autumn Brilliance' / Autumn Brilliance Serviceberry	2-2.5" CAL.	AG	3	20-30'
<i>Pyrus Calleryana</i> 'Cleveland' / Cleveland Pear	3-3.5" CAL.	CP	19	30-40'
<i>Syringa reticulata</i> / Japanese Lilac Tree	2-2.5" CAL.	SR	23	20-30'
Shrubs				
<i>Buddleia</i> 'Blue Chip' / Blue Chip Butterfly Bush	#3	BB	9	2-3'
<i>Clethra alnifolia</i> 'Compacta' / Compact Summersweet	#3	CA	65	3-4'
<i>Rhododendron</i> 'P.J.M.' / P.J.M. Rhododendron	#3	RP	4	5-6'
Grasses				
<i>Panicum virgatum</i> 'Shenandoah' / Shenandoah Switch Grass	#2	PV	6	3-4'

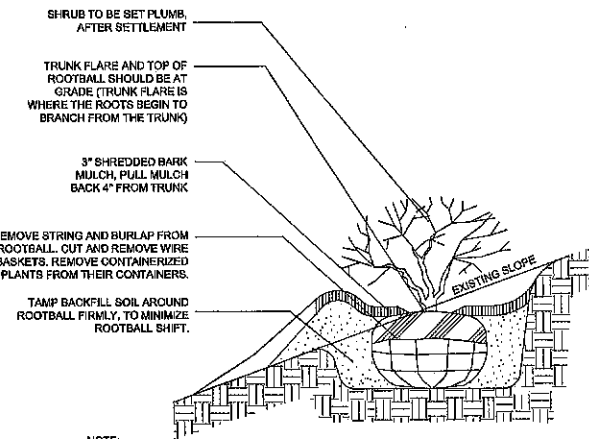

- NOTE:**
1. DO NOT HEAVILY PRUNE SHRUB AT PLANTING, PRUNE ONLY CROSSOVER LIMBS AND DAMAGED OR DEAD BRANCHES.
 2. BACKFILL WITH LOAM, AMEND AS REQUIRED BY LANDSCAPE ARCHITECT.
 3. SHRUBS & GROUND COVER PLANTED ADJACENT TO CITY SIDEWALKS NEED TO BE PLACED SO THE PLANTS, AT THEIR MATURE HEIGHT & WIDTH, WILL NOT ENCRoACH INTO THE CITY'S SIDEWALK.

TYPICAL SHRUB PLANTING

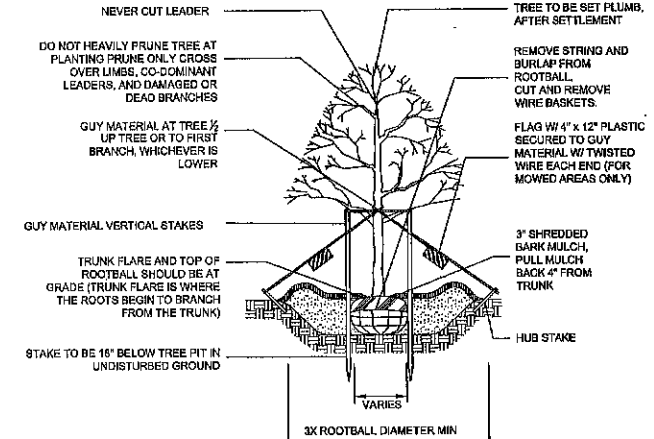

- NOTES:**
1. GUYING AND STAKING TO BE DETERMINED IN THE FIELD BY THE LANDSCAPE ARCHITECT. LOCAL FIELD CONDITIONS AS WELL AS PLANT CHARACTERISTICS WILL DETERMINE THE NECESSITY OF GUYING AND STAKING.
 2. TYPICALLY ONLY TREES WITH A 3" OR GREATER CALIPER NEED TO BE STAKED. TREES WITH LESS THAN A 3" CALIPER NEED TO BE STAKED ONLY AS REQUIRED BY LANDSCAPE ARCHITECT.
 3. ONLY WRAP TREE TRUNKS AS REQUIRED BY LANDSCAPE ARCHITECT.
 4. TREE SHALL BE SET PLUMB, AFTER SETTLEMENT.
 5. LOAM FOR BACKFILLING SHALL BE AMENDED AS REQUIRED BY LANDSCAPE ARCHITECT.
 6. CITY TREES PLANTED ON PRIVATE PROPERTY, ADJACENT TO A PUBLIC RIGHT-OF-WAY, NEED TO BE PLANTED A MINIMUM OF 6 FEET FROM THE EDGE OF THE CITY SIDEWALK.

DECIDUOUS TREE PLANTING

RECEIVED

JUL 02 2020

LAND USE OFFICE

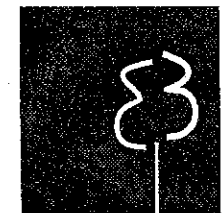

terrain
planning & design llc

311 kast hill road
hopkinton nh 03229
603.491.2322
terrainplanning.com

TRITECH
ENGINEERING CORPORATION

785 CENTRAL AVENUE
DOVER, NEW HAMPSHIRE 03804
TELEPHONE 603 748 8107
FAX 603 748 3880

REVISIONS	DATE	DESCRIPTION:
	6/30/20	ADDED TO PLAN SET

LANDSCAPE NOTES & DETAILS
BARRINGTON STORAGE-OFFICE
ROUTE #125
BARRINGTON, NEW HAMPSHIRE
NOVEMBER 14, 2019 JOB No. 19107
SCALE: 1" = 30'

SHEET No.

LA-2