



SALES | SERVICE | PARTS



Town of Barrington, NH



INVITATION TO BID

BID-BHD-03

Six Wheel Dump Truck

CONTAINING:

- LEGAL NOTICE OF BID
 - SPECIFICATIONS
 - BID FORM
- GENERAL CONDITIONS

Table of Contents

	Page
Legal Notice.....	ITB - 3
Specifications.....	S 4 - 7
BID Sheet	BID 8 - 11
General Conditions.....	GC 12 – 15
Notice of Award.....	N-16

LEGAL NOTICE

TOWN OF BARRINGTON, NH

INVITATION TO BID

2021 or Newer Model Six Wheel Dump Truck BID-BHD-03

Sealed Bids for the purchase of one (1) 2021 or Newer Model Six Wheel Dump Truck, for the Town of Barrington NH, will be received at the Town Hall, 333 Calef Highway, 2nd Floor, (mailing P.O. Box 660) Barrington NH, 03825 until 12:00 p.m. prevailing time, Wednesday January 19, 2022, at which time will be publicly opened.

The Bid shall be submitted in a sealed envelope, addressed to the Town of Barrington, Highway Department and clearly marked in the lower left-hand corner "TOB BID-BHD-03, 2021 or Newer Model Six Wheel Dump Truck.

The Bid document will be available at the Town Hall at the above address as well as online at <https://www.barrington.nh.gov/highway-department/pages/bids> beginning on Thursday December 8, 2021.

The Town of Barrington reserves the right to accept or reject any and all bids or any part thereof, and to waive any minor informalities as it deems to be in the best interest of the Town. The Town also reserves the right to conduct reasonable negotiations with low bidders and sole bidders. Failure to submit all information may declare a bid as non-responsive and subject to disqualification.

SPECIFICATIONS

2021 or Newer Model Six Wheel Dump Truck

Cab:

1. 108-inch aluminum cab
2. Severe service cab package includes aluminum side skins, aluminum rear.
3. Cab insulation package.
4. Fender extensions 2 inches wide.
5. Driver seat: air suspension, high back.
6. Passenger seat: non air suspension high back.
7. Arm rests, both sides.
8. Cloth free upholstery, Naugahyde, vinyl, etc.
9. Adjustable tilt telescope steering column with minimum 18-inch diameter steering wheel.
10. Rear window.
11. Curb view lower window in passenger side door.
12. Fiberglass tilt hood with access hatches.
13. Combination fresh air heater/ air conditioner.
14. Stainless steel west coast style heated mirrors.
15. Stainless steel heated convex mirrors.
16. Right hand down view mirror.
17. Manual door locks keyed alike with ignition.
18. 2 chrome 24.5 air horns with chrome shields.
19. Power window on passenger side only.
20. Standard AM/FM radio.
21. Manual reset circuit breakers where applicable.
22. Black rubber floor mats.
23. Left hand and right-hand chrome grab handles.
24. Dual electric horns.
25. 12-volt power supply in dash.
26. Intermittent electric windshield wipers with washers.
27. Electric backup alarm.
28. Air filter Restriction indicator in dash

Specifications Continued:

Gages:

1. Odometer
2. Hour Meter
3. Fuel and def gauge
4. Ammeter
5. Engine temperature
6. Oil pressure
7. Tachometer
8. Speedometer
9. Voltmeter
10. 5 auxiliary switches with wiring.
11. 5 cab marker lights, Amber.

Engine, Transmission and Driveline:

1. Diesel engine: Cummins ISL 330 horsepower: 1000-foot lbs. of torque or equivalent.
2. 120-volt ,1000-watt block heater with receptacle.
3. Engine brake.
4. Cooling: Minimum 1100 square inch radiator.
5. Engine driven power steering pump, direct driven, no belt.
6. Engine able to accept B20 biodiesel.
7. Transmission: Allison 3000 RDSP Automatic

Axles and Suspension:

1. Front:20,000-pound front axle with 20,000-pound leaf springs with spring buildup on the right side to carry the weight of a wing.
2. Iron hubs and front shocks.
3. Rear: 30,000-pound rear axle with 31,000-pound rear springs, and 3000-pound helper springs.
4. Iron hubs.
5. Heavy wall drive axle.
6. Differential lock, cab controlled with warning light.
7. 5:38 rear axle ratio.

Battery and Alternator:

1. Battery box, aluminum with aluminum cover, mounted on left side frame rail.
2. Batteries: 3 group 31,12-volt maintenance free,1950 CCA, threaded top stud.
3. Emergency jump studs mounted on or near battery box.
4. Alternator: 180-amp Delco Remy,12 volt.

Specifications Continued:

Brakes:

1. **Front:** 16.5x6 air s cam front brakes with dust shields, and gusseted cam brackets.
2. **Rear:** 16.5x7 air s cam rear brakes with dust shields and gusseted cam brackets.
3. Long stroke rear maxi brake chambers.
4. Brake chambers mounted on front of rear axle.

Steering:

1. Hydraulic power steering

Tires and Wheels:

Hubs:

1. Front & Rear - Conmet pre-set bearing cast iron
2. Front Tire – XZE2 xzu-s 11r-22.5, 16 ply radial
3. Rear Tire – XDE M/S 11R22.5 16 ply radial

Wheelbase and Frame:

1. Wheelbase: 166 inches.
2. Cab to axle: 96.2 inch.
3. Cab to end of frame: 158.9 inch.
4. Frame: 10.75-inch steel rails ,3/8 inch thick.
5. Crossmembers:
 - *Front closing.
 - *Weight, engine.
 - *Midship#1.
 - *Suspension.
 - *Rearmost.

Fuel Supply:

1. 50-gallon aluminum fuel tank under left side of cab.
2. Non slip fuel tank step.
3. Fuel filter heater, electric.
4. 6-gallon diesel exhaust fluid tank.

Specifications Continued:

Warning Devices:

1. Electric backup alarm
2. Dual note air horn
3. Dual electric horns

Tow Package:

1. Trailer towing provision at end of frame
2. Trailer connections: Primary connector receptacle wired for combination stop/turn; center pin powered through ignition with stop signal prewire package

Exterior Color:

1. Cab and hood: maroon
2. Frame: black

Air Equipment:

1. 18.7 cfm air compressor.
2. Bendix AD-IS air dryer with heater.
3. Front fender mud flaps.
4. Lanyard drain valves.
5. Aluminum air tanks.
6. Dual air brake system.
7. Bendix ABS without traction control.
8. Trailer air supply lines run to rear of frame.
9. Trolley valve in cab

Other:

1. 7-way commercial trailer wiring and receptacle run to rear of frame.
2. Vertical single exhaust stack with curved tip on right side of truck
3. Front fender mud flaps

BID FORM

**2021 or Newer Model Year
Six Wheel Dump Truck**

Bidder agrees to supply one (1) Six Wheel Dump Truck as indicated on Specification Sheet.

<u>ITEM</u>	<u>DESCRIPTION</u>	<u>AMOUNT</u>
One (1)	Six Wheel Dump Truck with Equipment	\$ <u>97,250</u>
	<u>TOTAL</u>	\$ <u>97,250</u>

Total Amount Ninety-seven thousand, two hundred fifty dollars
(Written)

Bid Form, continued

The above costs shall include the purchase and installation of all equipment specified on the said Specification Sheet. As previously referenced, the complete final product shall be operational and functional as intended by the Barrington Highway Department.

The Town reserves the right to accept and/or reject any Bid and also reserves the right to waive any informalities in the bidding procedures.

The Town reserves the right to accept the Bid Amount that is in the best interest of the Town.

List any and all deviations from the Specifications. If none are listed, it shall be assumed that the units offered, meet or exceed the minimum Specifications.

Attach complete set of Specifications and all other information requested in this BID-BHD-03. List all agencies where complete stocks or repair parts are maintained

ATG Manchester

(Business Name)

222 Frontage Rd

(Address)

Manchester, NH 03103

(City, State and Zip Code)

603-722-7662

(Phone Number)

Dated 28 day of December, 2021

Expected Delivery Date: Q3, 2022

providing availability from Freightliner.



(Signature of Bidder)

Charles T. Grand

(Printed Name)

Sales

(Title of Bidder)

Bid Form, continued

SPECIFICATIONS EXCEPTION FORM

In the interest of fairness and sound business practice, it is mandatory that you state any exceptions taken by you to our specifications.

It should not be the responsibility of the Town of Barrington to ferret out information concerning the materials which you intend to furnish.

If your bid does not meet all our specifications you must state it in the space provided below:

Bids on equipment, vehicles, computers, supplies, services and materials not meeting specifications may be considered by the Town, however, all deviations must be listed above.

If your Bid does not meet our specifications, and your exceptions are not listed above, the Town of Barrington may claim forfeiture on your Bid, if submitted.

Signed 

I DO meet specifications

Signed _____

I DO NOT meet specifications as listed in this Bid; exceptions are in the space provided

Failure to submit this form with your Bid response may result in your Bid being rejected as unresponsive.

Bid Form, continued

NON-COLLUSION STATEMENT

The Undersigned certifies under penalties of perjury that this Bid in all respects is bonafide, fair and made without collusion or fraud with any other person. As used in this paragraph, the "PERSON" shall mean any natural person, joint venture, partnership, corporation or other business or legal entity.

Title Seles

Signature 

Company ATG Manchester

INDEMNIFICATION AGREEMENT

The successful vendor agrees to indemnify, investigate, protect, defend and save harmless the Town of Barrington, NH, it's officials, officers, agents, and employees from any and all claims and losses accruing or resulting to any and all contractors, subcontractors, suppliers, laborers and any other person, firm or corporation furnishing or supplying work, services, materials, equipment or supplies in connection with the performance of this contract and from any and all claims and losses accruing or resulting to any person, firm or corporation which may be injured or damaged by the vendor in the performance of this contract. In any case, the forgoing provisions concerning indemnification shall not be construed to indemnify the Town for damage arising out of bodily injury to persons or damage to property caused by or resulting from the sole negligence of the Town or its employees. This indemnification shall survive the expiration or early termination of this contract.

Company ATG Manchester

Taxpayer ID Number 85-3109256

Authorized Signature and Date  J. LAGANA 12-28-21

Address 222 Frontage Rd Manchester, NH 03103

Telephone 603-621-8221

E-Mail cgrand11@mc Trucks.com

GENERAL CONDITIONS

PREPARATION OF BIDS

Bids shall be submitted on the forms provided and must be signed by an authorized representative of the firm submitting the said Bid. Any corrections to entries made on Bid forms should be initialed by the person signing the form.

Bidders must quote on all items appearing on the Bid forms unless specific directions in the advertisement or in the general provisions allow for partial Bids. Failure to quote on all items may disqualify the submitted proposal.

Alternative Bids will not be considered, unless otherwise stated, and then only if the alternate is described completely, including, but not limited to, sample(s) and specifications sufficient to enable for a comparison.

Unless otherwise stated in the Bid, prices quoted shall remain firm for a period of sixty (60) days after the date and time of receipt.

Any questions or inquiries must be submitted in writing, and must be received by the Barrington Highway Department no later than seven (7) calendar days before the Bid due date to be considered. Any changes to the Bid will be provided to all bidders of record.

The bidder has not divulged to, discussed or compared his bid with other firms and has not colluded with any other bidder or parties to a bid whatsoever. (NOTE: No premiums, rebates or gratuities permitted either with, prior to or after any delivery of materials. Any such violation will result in the cancellation and/or return of materials (as applicable) and may be grounds for the removal from future consideration).

The name of any manufacturer, trade name, or catalog number mentioned in this Bid description is intended for the purpose of designating a minimum standard of quality and type unless specified to be mandatory. Such references are not intended to be restrictive, although specified color, type of material, and specified measurements may be mandatory. Bids may be considered for any brand which meets or exceeds the quality of the specifications listed. On all such Bids, the bidder shall specify the product he is proposing and shall supply sufficient data to enable comparison to be made with the particular brand or manufacturer specified. Failure to submit the above may be sufficient grounds for rejection of the Bid.

When samples are required, they must be submitted free of cost and will be returned unless otherwise specified

Items left for demonstration purposes shall be delivered and installed free of charge and shall be removed by the vendor at no cost to the Town. Said demonstration units shall not be offered to the Town as new equipment unless otherwise mutually agreed to.

The vendor may be required to supply proof of compliance with specifications. When requested, the vendor must immediately supply the Town with certified test results of certificates of compliance. Where none are available, the Town may require independent laboratory testing. All costs for such testing certified test results or certificates of compliance shall be the responsibility of the vendor.

Unless otherwise stated, all prices are F.O.B. destination. No charge for packing or drayage will be allowed, all deliveries are to be prepaid, and C.O.D.'s will not be accepted.

BIDDERS INTERESTED IN MORE THAN ONE BID

If more than one Bid is offered by any one party, or by any person or persons representing a party, all such Bids shall be rejected. A party who has quoted prices to a bidder is not thereby disqualified from the quoting prices to the bidders or from submitting a direct Bid on his own behalf.

SUBMISSION OF BIDS

Bids must be submitted as directed in the Invitation-To-Bid, and on the forms provided unless otherwise specified. Bids must be typewritten or printed in ink.

WITHDRAWAL OF BID

Bids may be withdrawn prior to the opening date and time, upon written request of the bidder.

RECEIPT AND OPENING OF BIDS

Bids shall be submitted prior to the time indicated in the Invitation-To-Bid. Bids received after the time so indicated shall be returned unopened.

BID RESULTS

Bid results will be available on the Town of Barrington's website <https://www.barrington.nh.gov/>

THE BIDS

When identical low Bids are received, with respect to price, delivery and quality, the award may be made that is deemed to be in the best interest of the Town. When a tie Bid exists between a local and out-of-town bidder, preference will be given to the local bidder. Any bidder having a local agent who is a bona fide resident of the Town is considered a local bidder.

AWARD OF CONTRACT

The Contract may be awarded to the lowest responsible bidder (net total amount) as soon as approved and awarded by The Selectboard after Bid opening. The Town of Barrington reserves the right to waive any formality in Bids submitted and the right to reject any or all Bids at its discretion and to accept the Bid, which will be in the best interest of the Town.

In case of error in the extension of prices, the unit prices Bid shall govern and the unit prices in writing shall take precedence over the unit prices in figures.

DISQUALIFICATION

Awards will not be made to any person, firm or company in default of a contract with the Town.

SAFETY DATA SHEET

Right to know.

Any vendor who receives an order or orders resulting from this invitation agrees to submit a Material Safety Data Sheet (MSDS) for each toxic or hazardous substance or mixture containing such substance pursuant to RSA 277-A when deliveries are made. The vendor agrees to deliver all containers properly labeled pursuant to RSA 277-A. Failure to submit an MSDS and/or label on each container will place the vendor in noncompliance with the purchase order. Failure to submit MSDS and/or labels on each container may result in civil or criminal penalties, including bid debarment and action to prevent vendor from the selling said substances, or mixtures containing said substances within the state. All vendors furnishing substances or mixtures subject to RSA 277-A are cautioned to obtain and read the law referenced above.

FAILURE TO COMPLY WITH THE REQUIREMENTS COULD RESULT IN THE CANCELLATION OF AN ORDER OR CONTRACT.

PATENT PROTECTION

The seller agrees to indemnify and defend the Town of Barrington from all claims and losses resulting from the alleged and actual patent infringements and further agrees to hold the Town of Barrington harmless from any liability arising under RSA 382-A, 2-313 (3). (Uniform Commercial Code)

ASSIGNMENT PROVISION

The contractor/vendor hereby agrees that it will assign to the Town of Barrington all causes of action that it may acquire under the antitrust laws of New Hampshire and the United States as the result of conspiracies, combination or contracts in restraint of trade which affect the price goals or services obtained by the Town under this contract if so requested by the Town.

DELIVERY

Deliveries are to be made only to the department indicated on the order and in accordance with accepted commercial practices, without extra charge, or as designated elsewhere in the Bid.

Deliveries, which do not conform to the specifications or are not in good condition upon receipt, shall be replaced promptly.

INVOICING

Unless otherwise stated, invoices are to be submitted in duplicate upon delivery or pickup to the Barrington Highway Department. The invoice must include an itemization of all items, supplies, repairs or labor furnished, including unit list price, net price, extensions and total amount due. Any cash discount offered shall be clearly stated. Payment should be net thirty (30) days upon delivery.

TAX

The Town is exempt from all sales and Federal Excise Taxes. Exemption certificates will be furnished upon request, covering taxable items. Please bill less these taxes.

SEVERABILITY

If any of the GENERAL CONDITIONS is held to be invalid or unenforceable, it will be construed to have the broadest interpretation, which would make it valid and enforceable under such holding. Invalidity or unenforceability of a term or condition will not affect any of the other GENERAL CONDITIONS

DEFINITIONS

Bid shall also mean proposal, offer, qualification/experience statements, and services.

Bidders shall also mean vendors, offerors, or any person or firm responding to a request for bids

GOVERNING LAW

All contracts entered into by the Town of Barrington shall be governed by the Laws of the State of New Hampshire.

BIDDER QUALIFICATION

1. Shall have been engaged in the business of selling and servicing municipal equipment for a minimum of five (5) years.
2. Vendor shall have represented the product bid herein as a distributor for a minimum of five (5) years.
3. The distributor contractor/vendor shall have a service and parts facilities physically located in New Hampshire and must have parts available within 24 hours.

NOTICE-OF-AWARD

2021 or Newer Model Six Wheel Dump Truck – BID-BHD-03

TO: _____

PROJECT DESCRIPTION: 2021 or Newer Model Six Wheel Dump Truck – BID-BHD-03 in accordance with the Contract Documents/Specifications.

You are hereby notified that your Bid has been accepted in the amount of \$ _____ as per your bid dated _____ and awarded on January 24, 2022.

You are required by the Information for Bidders to execute the Agreement and furnish the required Contractor's Performance and Certificates of Insurance within ten (10) calendar days from the date of this Notice to you.

If you fail to execute said Agreement within ten (10) days from the date of this Notice, said Owner will be entitled to consider all your rights arising out of the Owner's acceptance of your Bid as abandoned and as a forfeiture of your Bid commitment. The Owner will be entitled to such other rights as may be granted by law.

You are required to return an acknowledged copy of the Notice-of-Award to the Owner.

Dated this _____ day of _____, 202____.

OWNER:

Town of Barrington, New Hampshire

By: _____

Conner Maclver, Town Administrator

ACCEPTANCE OF NOTICE

Receipt of the above Notice-of-Award is hereby acknowledged by _____ this the _____ day of _____ 202____.

By: _____ Title: _____

Prepared for:
Marc Moreau
BARRINGTON town of
333 Calef Highway
Barrington, NH 03825
Phone: 603-948-5203

Prepared by:
Charlie Grandll
ATG MANCHESTER LLC
222 FRONTAGE ROAD
MANCHESTER, NH 03103
Phone:

A proposal for
BARRINGTON town of

Prepared by
ATG MANCHESTER LLC
Charlie Grandll

Jan 13, 2022

Freightliner 108SD

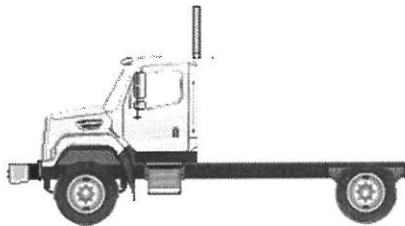

Components shown may not reflect all spec'd options and are not to scale



Prepared for:
Marc Moreau
BARRINGTON town of
333 Calef Highway
Barrington, NH 03825
Phone: 603-948-5203

Prepared by:
Charlie Grandll
ATG MANCHESTER LLC
222 FRONTAGE ROAD
MANCHESTER, NH 03103
Phone:

TABLE OF CONTENTS

QUOTATION	3
SPECIFICATION PROPOSAL	4
DIMENSIONS	19
TURNING RADIUS	21



Prepared for:
 Marc Moreau
 BARRINGTON town of
 333 Calef Highway
 Barrington, NH 03825
 Phone: 603-948-5203

Prepared by:
 Charlie Grandl
 ATG MANCHESTER LLC
 222 FRONTAGE ROAD
 MANCHESTER, NH 03103
 Phone:

Q U O T A T I O N

108SD CONVENTIONAL CHASSIS

SET BACK AXLE - TRUCK
 CUM L9 330 HP @ 2200 RPM; 2200 GOV RPM, 1000 LB-
 FT @ 1200 RPM
 ALLISON 3500 RDS AUTOMATIC TRANSMISSION WITH
 PTO PROVISION
 RS-30-185 30,000# U-SERIES SINGLE REAR AXLE
 30,000# FLAT LEAF SPRING REAR SUSPENSION WITH
 HELPER AND RADIUS ROD
 MFS-20-133A 20,000# FL1 71.0 INCH KPI/3.74 INCH
 DROP SINGLE FRONT AXLE

20,000# FLAT LEAF FRONT SUSPENSION
 108 INCH BBC FLAT ROOF ALUMINUM CONVENTIONAL
 CAB
 4125MM (162 INCH) WHEELBASE
 7/16X3-9/16X11-1/8 INCH STEEL FRAME
 (11.11MMX282.6MM/0.437X11.13 INCH) 120KSI
 1600MM (63 INCH) REAR FRAME OVERHANG
 BODY COMPANY INSTALLED ADDITIONAL FRONT
 FRAME REINFORCEMENT FOR SNOW PLOW

		PER UNIT		TOTAL
VEHICLE PRICE	TOTAL # OF UNITS (1)	\$ 97,426	\$	97,426
EXTENDED WARRANTY		\$ 0	\$	0
DEALER INSTALLED OPTIONS		\$ 0	\$	0
CUSTOMER PRICE BEFORE TAX		\$ 97,426	\$	97,426

TAXES AND FEES

FEDERAL EXCISE TAX (FET)	\$	(176)	\$	(176)
TAXES AND FEES	\$	0	\$	0
OTHER CHARGES	\$	0	\$	0

TRADE-IN

TRADE-IN ALLOWANCE	\$	(0)	\$	(0)
---------------------------	----	-----	----	-----

BALANCE DUE	(LOCAL CURRENCY)	\$ 97,250	\$	97,250
--------------------	-------------------------	------------------	-----------	---------------

COMMENTS:

Projected delivery on ___ / ___ / ___ provided the order is received before ___ / ___ / ___.

APPROVAL:

Please indicate your acceptance of this quotation by signing below:

Customer: X _____ Date: ___ / ___ / ___.

Daimler Truck Financial

Financing that works for you.

See your local dealer for a competitive quote from Daimler Truck Financial, or contact us at Information@dtfoffers.com.

Daimler Truck Financial offers a variety of finance, lease and insurance solutions to fit your business needs. For more information about our products and services, visit our website at www.daimler-truckfinancial.com.



Prepared for:
 Marc Moreau
 BARRINGTON town of
 333 Calef Highway
 Barrington, NH 03825
 Phone: 603-948-5203

Prepared by:
 Charlie Grandll
 ATG MANCHESTER LLC
 222 FRONTAGE ROAD
 MANCHESTER, NH 03103
 Phone:

S P E C I F I C A T I O N P R O P O S A L

Data Code	Description	Weight Front	Weight Rear	Retail Price
Price Level				
PRL-26D	SD PRL-26D (EFF:7/26/21)			STD
Data Version				
DRL-030	SPECPRO21 DATA RELEASE VER 030			N/C
Vehicle Configuration				
001-176	108SD CONVENTIONAL CHASSIS	6,829	3,748	\$124,670.00
004-223	2023 MODEL YEAR SPECIFIED			STD
002-004	SET BACK AXLE - TRUCK			STD
019-001	TRAILER TOWING PROVISION AT END OF FRAME FOR TRUCK	10	10	\$1,025.00
003-001	LH PRIMARY STEERING LOCATION			STD
General Service				
AA1-003	TRUCK/TRAILER CONFIGURATION			N/C
AA6-001	DOMICILED, USA 50 STATES (INCLUDING CALIFORNIA AND CARB OPT-IN STATES)			STD
A85-010	UTILITY/REPAIR/MAINTENANCE SERVICE			N/C
A84-1GM	GOVERNMENT BUSINESS SEGMENT			N/C
AA4-010	DIRT/SAND/ROCK COMMODITY			N/C
AA5-002	TERRAIN/DUTY: 100% (ALL) OF THE TIME, IN TRANSIT, IS SPENT ON PAVED ROADS			STD
AB1-008	MAXIMUM 8% EXPECTED GRADE			STD
AB5-001	SMOOTH CONCRETE OR ASPHALT PAVEMENT - MOST SEVERE IN-TRANSIT (BETWEEN SITES) ROAD SURFACE			STD
995-1A0	FREIGHTLINER SD VOCATIONAL WARRANTY			STD
A66-99D	EXPECTED FRONT AXLE(S) LOAD : 13220.0 lbs			
A68-99D	EXPECTED REAR DRIVE AXLE(S) LOAD : 24020.0 lbs			
A63-99D	EXPECTED GROSS VEHICLE WEIGHT CAPACITY : 37240.0 lbs			
A70-99D	EXPECTED GROSS COMBINATION WEIGHT : 80000.0 lbs			



Prepared for:
 Marc Moreau
 BARRINGTON town of
 333 Calef Highway
 Barrington, NH 03825
 Phone: 603-948-5203

Prepared by:
 Charlie Grandll
 ATG MANCHESTER LLC
 222 FRONTAGE ROAD
 MANCHESTER, NH 03103
 Phone:

Data Code	Description	Weight Front	Weight Rear	Retail Price
Truck Service				
AA3-018	FRONT PLOW/END DUMP BODY			N/C
AF3-265	H.P.FAIRFIELD			N/C
Tractor Service				
AA2-005	FLATBED TRAILER			N/C
AH6-001	SINGLE (1) TRAILER			N/C
Engine				
101-3BP	CUM L9 330 HP @ 2200 RPM; 2200 GOV RPM, 1000 LB-FT @ 1200 RPM			\$3,051.00
Electronic Parameters				
79A-065	65 MPH ROAD SPEED LIMIT			N/C
79B-000	CRUISE CONTROL SPEED LIMIT SAME AS ROAD SPEED LIMIT			N/C
79K-007	PTO MODE ENGINE RPM LIMIT - 1100 RPM			N/C
79M-001	PTO MODE BRAKE OVERRIDE - SERVICE BRAKE APPLIED			N/C
79P-003	PTO RPM WITH CRUISE SET SWITCH - 800 RPM			N/C
79Q-003	PTO RPM WITH CRUISE RESUME SWITCH - 800 RPM			N/C
79S-001	PTO MODE CANCEL VEHICLE SPEED - 5 MPH			N/C
79U-007	PTO GOVERNOR RAMP RATE - 250 RPM PER SECOND			N/C
* 80P-998	NO FLEET SPEC FOR PARAMETERIZATION			N/C
80G-002	PTO MINIMUM RPM - 700			N/C
80J-002	REGEN INHIBIT SPEED THRESHOLD - 5 MPH			N/C
Engine Equipment				
99C-021	2010 EPA/CARB/GHG21 CONFIGURATION			STD
99D-009	2008 CARB EMISSION CERTIFICATION - CLEAN IDLE (INCLUDES 6X4 INCH LABEL ON LEFT SIDE OF HOOD)			\$109.00
13E-001	STANDARD OIL PAN			STD
105-015	OIL FILL AND DIPSTICK LOCATED FOR ENHANCED SERVICEABILITY			\$83.00
014-1C5	SIDE OF HOOD AIR INTAKE WITH FIREWALL MOUNTED DONALDSON AIR CLEANER AND INSIDE/OUTSIDE AIR WITH SNOW DOOR	10		\$578.00
124-1D9	DR 12V 180 AMP 28-SI QUADRAMOUNT PAD ALTERNATOR WITH REMOTE BATTERY VOLT SENSE			\$62.00
292-206	(3) DTNA GENUINE, FLOODED STARTING, MIN 2850CCA, 525RC, THREADED STUD BATTERIES	40	20	\$227.00



Prepared for:
 Marc Moreau
 BARRINGTON town of
 333 Calef Highway
 Barrington, NH 03825
 Phone: 603-948-5203

Prepared by:
 Charlie Grandll
 ATG MANCHESTER LLC
 222 FRONTAGE ROAD
 MANCHESTER, NH 03103
 Phone:

Data Code	Description	Weight Front	Weight Rear	Retail Price
290-017	BATTERY BOX FRAME MOUNTED			STD
281-001	STANDARD BATTERY JUMPERS			STD
282-001	SINGLE BATTERY BOX FRAME MOUNTED LH SIDE UNDER CAB			\$18.00
291-017	WIRE GROUND RETURN FOR BATTERY CABLES WITH ADDITIONAL FRAME GROUND RETURN			STD
289-001	NON-POLISHED BATTERY BOX COVER			STD
87P-001	CAB AUXILIARY POWER CABLE	5		\$62.00
293-058	POSITIVE LOAD DISCONNECT WITH CAB MOUNTED CONTROL SWITCH MOUNTED OUTBOARD DRIVER SEAT	10		\$206.00
295-029	POSITIVE AND NEGATIVE POSTS FOR JUMPSTART LOCATED ON FRAME NEXT TO STARTER	2		\$88.00
107-032	CUMMINS TURBOCHARGED 18.7 CFM AIR COMPRESSOR WITH INTERNAL SAFETY VALVE			STD
152-041	ELECTRONIC ENGINE INTEGRAL SHUTDOWN PROTECTION SYSTEM			STD
128-076	CUMMINS ENGINE INTEGRAL BRAKE WITH VARIABLE GEOMETRY TURBO ON/OFF	20		STD
016-1C2	RH OUTBOARD UNDER STEP MOUNTED HORIZONTAL AFTERTREATMENT SYSTEM ASSEMBLY WITH RH B-PILLAR MOUNTED VERTICAL TAILPIPE	30	25	\$816.00
28F-002	ENGINE AFTERTREATMENT DEVICE, AUTOMATIC OVER THE ROAD REGENERATION AND DASH MOUNTED REGENERATION REQUEST SWITCH			N/C
239-026	10 FOOT 06 INCH (126 INCH+0/-5.9 INCH) EXHAUST SYSTEM HEIGHT			(\$3.00)
237-1CR	RH CURVED VERTICAL TAILPIPE B-PILLAR MOUNTED ROUTED FROM STEP			N/C
23U-001	6 GALLON DIESEL EXHAUST FLUID TANK	-35	-10	N/C
30N-003	100 PERCENT DIESEL EXHAUST FLUID FILL			(\$17.00)
23Y-001	STANDARD DIESEL EXHAUST FLUID PUMP MOUNTING			STD
43X-002	LH MEDIUM DUTY STANDARD DIESEL EXHAUST FLUID TANK LOCATION			STD
43Y-001	STANDARD DIESEL EXHAUST FLUID TANK CAP			STD
242-001	STAINLESS STEEL AFTERTREATMENT DEVICE/MUFFLER/TAILPIPE SHIELD			\$48.00
273-018	HORTON DRIVEMASTER ADVANTAGE ON/OFF FAN DRIVE			N/C
276-001	AUTOMATIC FAN CONTROL WITHOUT DASH SWITCH, NON ENGINE MOUNTED			STD



Prepared for:
 Marc Moreau
 BARRINGTON town of
 333 Calef Highway
 Barrington, NH 03825
 Phone: 603-948-5203

Prepared by:
 Charlie Grandll
 ATG MANCHESTER LLC
 222 FRONTAGE ROAD
 MANCHESTER, NH 03103
 Phone:

Data Code	Description	Weight Front	Weight Rear	Retail Price
110-003	CUMMINS SPIN ON FUEL FILTER			STD
118-008	COMBINATION FULL FLOW/BYPASS OIL FILTER			STD
266-104	1115 SQUARE INCH ALUMINUM RADIATOR			STD
103-037	ANTIFREEZE TO -60F, ETHYLENE GLYCOL PRE-CHARGED SCA HEAVY DUTY COOLANT			\$10.00
171-007	GATES BLUE STRIPE COOLANT HOSES OR EQUIVALENT			STD
172-007	GATES POWERGRIP SHRINK BAND HOSE CLAMPS WHERE POSSIBLE			\$117.00
270-016	RADIATOR DRAIN VALVE			STD
360-016	1310 ADAPTER FLANGE FOR FRONT PTO PROVISION	10		\$624.00
138-011	PHILLIPS-TEMRO 1000 WATT/115 VOLT BLOCK HEATER	4		\$92.00
140-022	CHROME ENGINE HEATER RECEPTACLE MOUNTED UNDER LH DOOR			\$6.00
132-004	ELECTRIC GRID AIR INTAKE WARMER			STD
155-058	DELCO 12V 38MT HD STARTER WITH INTEGRATED MAGNETIC SWITCH			STD
Transmission				
342-584	ALLISON 3500 RDS AUTOMATIC TRANSMISSION WITH PTO PROVISION			(\$75.00)
Transmission Equipment				
343-339	ALLISON VOCATIONAL PACKAGE 223 - AVAILABLE ON 3000/4000 PRODUCT FAMILIES WITH VOCATIONAL MODELS RDS, HS, MH AND TRV			STD
84B-012	ALLISON VOCATIONAL RATING FOR ON/OFF HIGHWAY APPLICATIONS AVAILABLE WITH ALL PRODUCT FAMILIES			N/C
84C-023	PRIMARY MODE GEARS, LOWEST GEAR 1, START GEAR 1, HIGHEST GEAR 6, AVAILABLE FOR 3000/4000 PRODUCT FAMILIES ONLY			STD
84D-020	SECONDARY MODE GEARS, LOWEST GEAR 1, START GEAR 1, HIGHEST GEAR 3, AVAILABLE FOR 3000/4000 PRODUCT FAMILIES ONLY			N/C
84E-000	PRIMARY SHIFT SCHEDULE RECOMMENDED BY DTNA AND ALLISON, THIS DEFINED BY ENGINE AND VOCATIONAL USAGE			STD
84F-000	SECONDARY SHIFT SCHEDULE RECOMMENDED BY DTNA AND ALLISON, THIS DEFINED BY ENGINE AND VOCATIONAL USAGE			STD
84G-000	PRIMARY SHIFT SPEED RECOMMENDED BY DTNA AND ALLISON, THIS DEFINED BY ENGINE AND VOCATIONAL USAGE			STD



Prepared for:
 Marc Moreau
 BARRINGTON town of
 333 Calef Highway
 Barrington, NH 03825
 Phone: 603-948-5203

Prepared by:
 Charlie Grandll
 ATG MANCHESTER LLC
 222 FRONTAGE ROAD
 MANCHESTER, NH 03103
 Phone:

Data Code	Description	Weight Front	Weight Rear	Retail Price
84H-000	SECONDARY SHIFT SPEED RECOMMENDED BY DTNA AND ALLISON, THIS DEFINED BY ENGINE AND VOCATIONAL USAGE			STD
84N-200	FUEL SENSE 2.0 DISABLED - PERFORMANCE - TABLE BASED			STD
84U-000	DRIVER SWITCH INPUT - DEFAULT - NO SWITCHES			STD
353-022	VEHICLE INTERFACE WIRING CONNECTOR WITHOUT BLUNT CUTS, AT BACK OF CAB			\$49.00
34C-002	ELECTRONIC TRANSMISSION CUSTOMER ACCESS CONNECTOR MOUNTED BACK OF CAB			\$76.00
362-823	CUSTOMER INSTALLED CHELSEA 280 SERIES PTO			N/C
363-001	PTO MOUNTING, LH SIDE OF MAIN TRANSMISSION ALLISON			N/C
341-018	MAGNETIC PLUGS, ENGINE DRAIN, TRANSMISSION DRAIN, AXLE(S) FILL AND DRAIN			STD
345-003	PUSH BUTTON ELECTRONIC SHIFT CONTROL, DASH MOUNTED			STD
97G-004	TRANSMISSION PROGNOSTICS - ENABLED 2013			STD
370-015	WATER TO OIL TRANSMISSION COOLER, IN RADIATOR END TANK			STD
346-013	TRANSMISSION OIL CHECK AND FILL WITH CROSSOVER TO CLEAR LH PTO AND DIRECT MOUNT PUMP			\$61.00
35T-001	SYNTHETIC TRANSMISSION FLUID (TES-295 COMPLIANT)			STD

Front Axle and Equipment

400-1AC	MFS-20-133A 20,000# FL1 71.0 INCH KPI/3.74 INCH DROP SINGLE FRONT AXLE	260		\$3,576.00
402-030	MERITOR 16.5X6 Q+ CAST SPIDER CAM FRONT BRAKES, DOUBLE ANCHOR, FABRICATED SHOES	10		N/C
403-002	NON-ASBESTOS FRONT BRAKE LINING			STD
419-023	CONMET CAST IRON FRONT BRAKE DRUMS			\$8.00
427-001	FRONT BRAKE DUST SHIELDS	5		\$102.00
409-006	FRONT OIL SEALS			STD
408-001	VENTED FRONT HUB CAPS WITH WINDOW, CENTER AND SIDE PLUGS - OIL			STD
416-022	STANDARD SPINDLE NUTS FOR ALL AXLES			STD
405-031	HALDEX AUTOMATIC FRONT SLACK ADJUSTERS WITH STAINLESS STEEL CLEVIS PINS			\$60.00



Prepared for:
 Marc Moreau
 BARRINGTON town of
 333 Calef Highway
 Barrington, NH 03825
 Phone: 603-948-5203

Prepared by:
 Charlie Grandll
 ATG MANCHESTER LLC
 222 FRONTAGE ROAD
 MANCHESTER, NH 03103
 Phone:

Data Code	Description	Weight Front	Weight Rear	Retail Price
406-001	STANDARD KING PIN BUSHINGS			STD
536-055	TRW THP-60 POWER STEERING WITH RCH45 AUXILIARY GEAR	130		N/C
539-003	POWER STEERING PUMP			STD
534-003	4 QUART POWER STEERING RESERVOIR			N/C
533-001	OIL/AIR POWER STEERING COOLER			N/C
40T-004	GUARANTEED NAME BRAND "ROADRANGER SYNTHETIC" FE 75W-90 FRONT AXLE LUBE			\$31.00
Front Suspension				
620-006	20,000# FLAT LEAF FRONT SUSPENSION	310		\$815.00
619-004	GRAPHITE BRONZE BUSHINGS WITH SEALS - FRONT SUSPENSION			N/C
62G-998	NO FRONT SUSPENSION OPTIONS			STD
410-001	FRONT SHOCK ABSORBERS			\$121.00
Rear Axle and Equipment				
420-024	RS-30-185 30,000# U-SERIES SINGLE REAR AXLE		275	\$7,269.00
421-563	5.63 REAR AXLE RATIO			N/C
424-001	IRON REAR AXLE CARRIER WITH STANDARD AXLE HOUSING			STD
386-073	MXL 17T MERITOR EXTENDED LUBE MAIN DRIVELINE WITH HALF ROUND YOKES			STD
452-001	DRIVER CONTROLLED TRACTION DIFFERENTIAL - SINGLE REAR AXLE		20	\$734.00
878-018	(1) DRIVER CONTROLLED DIFFERENTIAL LOCK REAR VALVE FOR SINGLE DRIVE AXLE			N/C
87B-004	BLINKING LAMP WITH EACH MODE SWITCH, DIFFERENTIAL UNLOCK WITH IGNITION OFF, ACTIVE <5 MPH			N/C
423-010	MERITOR 16.5X7 P CAST SPIDER CAM REAR BRAKES, DOUBLE ANCHOR, CAST SHOES		20	N/C
433-002	NON-ASBESTOS REAR BRAKE LINING			STD
434-011	BRAKE CAMS AND CHAMBERS ON FORWARD SIDE OF DRIVE AXLE(S)			N/C
451-018	WEBB CAST IRON REAR BRAKE DRUMS		50	N/C
425-002	REAR BRAKE DUST SHIELDS		5	\$65.00
440-006	REAR OIL SEALS			STD
426-100	WABCO TRISTOP D LONGSTROKE 1-DRIVE AXLE SPRING PARKING CHAMBERS			STD
428-003	HALDEX AUTOMATIC REAR SLACK ADJUSTERS			\$47.00
41T-002	CURRENT AVAILABLE SYNTHETIC 75W-90 REAR AXLE LUBE			STD



Prepared for:
 Marc Moreau
 BARRINGTON town of
 333 Calef Highway
 Barrington, NH 03825
 Phone: 603-948-5203

Prepared by:
 Charlie Grandll
 ATG MANCHESTER LLC
 222 FRONTAGE ROAD
 MANCHESTER, NH 03103
 Phone:

Data Code	Description	Weight Front	Weight Rear	Retail Price
42T-001	STANDARD REAR AXLE BREATHER(S)			STD
Rear Suspension				
622-1DF	30,000# FLAT LEAF SPRING REAR SUSPENSION WITH HELPER AND RADIUS ROD		160	\$463.00
621-001	SPRING SUSPENSION - NO AXLE SPACERS			N/C
431-001	STANDARD AXLE SEATS IN AXLE CLAMP GROUP			STD
623-005	FORE/AFT CONTROL RODS			STD
Brake System				
490-100	WABCO 4S/4M ABS			STD
871-001	REINFORCED NYLON, FABRIC BRAID AND WIRE BRAID CHASSIS AIR LINES			STD
904-001	FIBER BRAID PARKING BRAKE HOSE			STD
412-001	STANDARD BRAKE SYSTEM VALVES			STD
46D-002	STANDARD AIR SYSTEM PRESSURE PROTECTION SYSTEM			STD
413-002	STD U.S. FRONT BRAKE VALVE			STD
432-003	RELAY VALVE WITH 5-8 PSI CRACK PRESSURE, NO REAR PROPORTIONING VALVE			STD
480-088	WABCO SYSTEM SAVER HP WITH INTEGRAL AIR GOVERNOR AND HEATER			STD
479-003	AIR DRYER MOUNTED INBOARD ON LH RAIL			N/C
460-007	ALUMINUM AIR BRAKE RESERVOIRS	-10	-15	\$262.00
607-001	CLEAR FRAME RAILS FROM BACK OF CAB TO FRONT REAR SUSPENSION BRACKET, BOTH RAILS OUTBOARD			\$218.00
477-004	PULL CABLES ON ALL AIR RESERVOIR(S)			\$3.00
Trailer Connections				
914-001	AIR CONNECTIONS TO END OF FRAME WITH GLAD HANDS FOR TRUCK AND NO DUST COVERS			N/C
296-027	PRIMARY CONNECTOR/RECEPTACLE WIRED FOR COMBINATION STOP/TURN, CENTER PIN POWERED THROUGH IGNITION WITH STOP SIGNAL PREWIRE PACKAGE			\$59.00
297-001	SAE J560 7-WAY PRIMARY TRAILER CABLE RECEPTACLE MOUNTED END OF FRAME			N/C
335-004	UPGRADED CHASSIS MULTIPLEXING UNIT			STD
331-001	SUPPLEMENTAL J560 7-WAY RECEPTACLE LOCATED WITH PRIMARY RECEPTACLE			\$91.00
Wheelbase & Frame				
545-412	4125MM (162 INCH) WHEELBASE			N/C



Prepared for:
 Marc Moreau
 BARRINGTON town of
 333 Calef Highway
 Barrington, NH 03825
 Phone: 603-948-5203

Prepared by:
 Charlie Grandll
 ATG MANCHESTER LLC
 222 FRONTAGE ROAD
 MANCHESTER, NH 03103
 Phone:

Data Code	Description	Weight Front	Weight Rear	Retail Price
546-102	7/16X3-9/16X11-1/8 INCH STEEL FRAME (11.11MMX282.6MM/0.437X11.13 INCH) 120KSI	170	150	\$720.00
548-803	BODY COMPANY INSTALLED ADDITIONAL FRONT FRAME REINFORCEMENT FOR SNOW PLOW			N/C
552-030	1600MM (63 INCH) REAR FRAME OVERHANG			STD
55W-006	FRAME OVERHANG RANGE: 61 INCH TO 70 INCH			N/C
549-002	24 INCH INTEGRAL FRONT FRAME EXTENSION	140	-20	\$4.00
AC8-99D	CALC'D BACK OF CAB TO REAR SUSP C/L (CA) : 96.85 in			
AE8-99D	CALCULATED EFFECTIVE BACK OF CAB TO REAR SUSPENSION C/L (CA) : 93.85 in			
AE4-99D	CALC'D FRAME LENGTH - OVERALL : 290.55 in			
FSS-0LH	CALCULATED FRAME SPACE LH SIDE : 60.17 in			N/C
FSS-0RH	CALCULATED FRAME SPACE RH SIDE : 124.8 in			N/C
553-001	SQUARE END OF FRAME			STD
550-001	FRONT CLOSING CROSSMEMBER			STD
559-003	LIGHTWEIGHT HEAVY DUTY ALUMINUM ENGINE CROSSMEMBER	-12		\$50.00
562-001	STANDARD MIDSHIP #1 CROSSMEMBER(S)			STD
572-001	STANDARD REAR MOST CROSSMEMBER			STD
565-001	STANDARD SUSPENSION CROSSMEMBER			STD
Chassis Equipment				
556-997	OMIT FRONT BUMPER, CUSTOMER INSTALLED SPECIAL BUMPER, DOES NOT COMPLY WITH FMCSR 393.203	-110		(\$488.00)
558-001	FRONT TOW HOOKS - FRAME MOUNTED	15		\$80.00
551-002	HUCK-SPIN ROUND COLLAR CHASSIS FASTENERS			\$369.00
Fuel Tanks				
204-215	50 GALLON/189 LITER SHORT RECTANGULAR ALUMINUM FUEL TANK - LH	-10		\$30.00
218-005	RECTANGULAR FUEL TANK(S)			N/C
215-005	PLAIN ALUMINUM/PAINTED STEEL FUEL/HYDRAULIC TANK(S) WITH PAINTED BANDS			STD
212-007	FUEL TANK(S) FORWARD			STD
664-001	PLAIN STEP FINISH			STD
205-001	FUEL TANK CAP(S)			STD
122-1H7	DAVCO 245 FUEL/WATER SEPARATOR WITH WATER IN FUEL SENSOR	5		\$246.00



Prepared for:
 Marc Moreau
 BARRINGTON town of
 333 Calef Highway
 Barrington, NH 03825
 Phone: 603-948-5203

Prepared by:
 Charlie Grandll
 ATG MANCHESTER LLC
 222 FRONTAGE ROAD
 MANCHESTER, NH 03103
 Phone:

Data Code	Description	Weight Front	Weight Rear	Retail Price
216-020	EQUIFLO INBOARD FUEL SYSTEM			STD
202-016	HIGH TEMPERATURE REINFORCED NYLON FUEL LINE			STD
Tires				
093-1AX	MICHELIN XZE2 11R22.5 16 PLY RADIAL FRONT TIRES	24		(\$38.00)
094-1UY	MICHELIN X MULTI D 11R22.5 16 PLY RADIAL REAR TIRES		60	(\$40.00)
Hubs				
418-060	CONMET PRESET PLUS PREMIUM IRON FRONT HUBS			STD
450-014	WEBB IRON REAR HUBS		280	N/C
Wheels				
502-428	ACCURIDE 28828 22.5X8.25 10-HUB PILOT 6.18 INSET 2-HAND HD STEEL DISC FRONT WHEELS	26		STD
505-428	ACCURIDE 28828 22.5X8.25 10-HUB PILOT 2-HAND HD STEEL DISC REAR WHEELS		52	STD
496-011	FRONT WHEEL MOUNTING NUTS			STD
497-011	REAR WHEEL MOUNTING NUTS			STD
495-998	NO PUSHER/TAG WHEEL MOUNTING NUTS			STD
498-011	NYLON WHEEL GUARDS FRONT AND REAR ALL INTERFACES			\$29.00
Cab Exterior				
829-1A5	108 INCH BBC FLAT ROOF ALUMINUM CONVENTIONAL CAB			STD
650-008	AIR CAB MOUNTING			STD
648-002	NONREMOVABLE BUGSCREEN MOUNTED BEHIND GRILLE			STD
667-037	SHORT FENDER WITH MUDFLAP			\$141.00
754-017	BOLT-ON MOLDED FLEXIBLE FENDER EXTENSIONS	10		\$115.00
678-018	LH AND RH EXTERIOR GRAB HANDLES WITH SINGLE RUBBER INSERT			\$54.00
645-002	BRIGHT FINISH RADIATOR SHELL/HOOD BEZEL			\$253.00
646-042	STATIONARY BLACK GRILLE WITH BRIGHT ACCENTS			\$88.00
65X-003	CHROME HOOD MOUNTED AIR INTAKE GRILLE			\$15.00
644-006	FIBERGLASS HOOD WITH ACCESS HATCHES	10		\$682.00
727-1AM	DUAL 24 INCH ROUND POLISHED ALUMINUM AIR HORNS ROOF MOUNTED	4		\$75.00
726-002	DUAL ELECTRIC HORNS			\$14.00



Prepared for:
 Marc Moreau
 BARRINGTON town of
 333 Calef Highway
 Barrington, NH 03825
 Phone: 603-948-5203

Prepared by:
 Charlie Grandll
 ATG MANCHESTER LLC
 222 FRONTAGE ROAD
 MANCHESTER, NH 03103
 Phone:

Data Code	Description	Weight Front	Weight Rear	Retail Price
728-002	DUAL HORN SHIELDS			N/C
657-001	DOOR LOCKS AND IGNITION SWITCH KEYED THE SAME			STD
78G-004	KEY QUANTITY OF 4			\$18.00
575-001	REAR LICENSE PLATE MOUNT END OF FRAME			STD
312-067	HALOGEN COMPOSITE HEADLAMPS WITH BRIGHT BEZELS			N/C
302-047	LED AERODYNAMIC MARKER LIGHTS			\$34.00
311-025	HEADLIGHTS ON WITH WIPERS, WITH LOW BEAM DAYTIME RUNNING LIGHTS			\$21.00
294-001	INTEGRAL STOP/TAIL/BACKUP LIGHTS			STD
300-015	STANDARD FRONT TURN SIGNAL LAMPS			STD
744-1BC	DUAL WEST COAST BRIGHT FINISH HEATED MIRRORS WITH LH AND RH REMOTE			\$286.00
797-001	DOOR MOUNTED MIRRORS			STD
796-001	102 INCH EQUIPMENT WIDTH			STD
743-204	LH AND RH 8 INCH BRIGHT FINISH CONVEX MIRRORS MOUNTED UNDER PRIMARY MIRRORS			N/C
74A-001	RH DOWN VIEW MIRROR			\$21.00
74B-1B4	RH AND LH 8 INCH HEATED STAINLESS STEEL FENDER MOUNTED CONVEX MIRRORS WITH TRIPOD BRACKETS	12		\$281.00
729-001	STANDARD SIDE/REAR REFLECTORS			STD
677-055	RH AFTERTREATMENT SYSTEM CAB ACCESS WITH POLISHED DIAMOND PLATE COVER			\$142.00
275-061	PARK BRAKE REMINDER WARNING SYSTEM			\$9.00
764-010	COMPOSITE EXTERIOR SUN VISOR	10		\$247.00
768-043	63X14 INCH TINTED REAR WINDOW			STD
661-004	TINTED DOOR GLASS LH AND RH WITH TINTED OPERATING WING WINDOWS			STD
654-027	RH AND LH ELECTRIC POWERED WINDOWS, PASSENGER SWITCHES ON DOOR(S)	4		\$218.00
663-029	1-PIECE BONDED HEATED WIPER PARK SOLAR GREEN GLASS WINDSHIELD			\$423.00
659-007	8 LITER (2 GAL) WINDSHIELD WASHER RESERVOIR, CAB MOUNTED, WITHOUT FLUID LEVEL INDICATOR			STD

Cab Interior

707-1AK	OPAL GRAY VINYL INTERIOR			STD
706-026	MOLDED PLASTIC DOOR PANEL WITHOUT VINYL INSERT WITH ALUMINUM KICKPLATE LOWER DOOR			\$27.00



Prepared for:
 Marc Moreau
 BARRINGTON town of
 333 Calef Highway
 Barrington, NH 03825
 Phone: 603-948-5203

Prepared by:
 Charlie Grandll
 ATG MANCHESTER LLC
 222 FRONTAGE ROAD
 MANCHESTER, NH 03103
 Phone:

Data Code	Description	Weight Front	Weight Rear	Retail Price
708-026	MOLDED PLASTIC DOOR PANEL WITHOUT VINYL INSERT WITH ALUMINUM KICKPLATE LOWER DOOR			\$27.00
772-006	BLACK MATS WITH SINGLE INSULATION			STD
785-998	NO DASH MOUNTED ASH TRAYS AND LIGHTER			(\$5.00)
691-998	NO FORWARD ROOF MOUNTED CONSOLE			(\$12.00)
694-010	IN DASH STORAGE BIN			N/C
696-012	CENTER STORAGE CONSOLE MOUNTED ON BACKWALL	20		\$26.00
742-007	(2) CUP HOLDERS LH AND RH DASH			STD
680-006	GRAY/CHARCOAL FLAT DASH			N/C
860-004	SMART SWITCH EXPANSION MODULE			\$196.00
720-002	2-1/2 LB. FIRE EXTINGUISHER	5		\$37.00
714-001	FIRST AID KIT	2		\$24.00
700-002	HEATER, DEFROSTER AND AIR CONDITIONER			STD
701-008	STANDARD HVAC DUCTING WITH SNOW SHIELD FOR FRESH AIR INTAKE			\$31.00
703-005	MAIN HVAC CONTROLS WITH RECIRCULATION SWITCH			STD
170-019	STANDARD HEATER PLUMBING WITH BALL SHUTOFF VALVES			\$37.00
130-041	VALEO HEAVY DUTY A/C REFRIGERANT COMPRESSOR			STD
702-002	BINARY CONTROL, R-134A			STD
739-034	PREMIUM INSULATION			\$145.00
285-027	SOLID-STATE CIRCUIT PROTECTION AND FUSES WITH SPARE FUSE KIT			\$34.00
280-007	12V NEGATIVE GROUND ELECTRICAL SYSTEM			STD
324-011	DOME DOOR ACTIVATED LH AND RH, DUAL READING LIGHTS, FORWARD CAB ROOF			N/C
655-005	LH AND RH ELECTRIC DOOR LOCKS			\$36.00
284-045	(2) 12 VOLT POWER RECEPTACLES MOUNTED IN DASH			\$1.00
722-002	TRIANGULAR REFLECTORS WITHOUT FLARES	10		\$24.00
756-339	PREMIUM ISRINGHAUSEN HIGH BACK AIR SUSPENSION DRIVERS SEAT WITH 2 AIR LUMBAR, INTEGRATED CUSHION EXTENSION, TILT AND ADJUSTABLE SHOCK	70		\$414.00
760-337	BASIC ISRINGHAUSEN HIGH BACK NON SUSPENSION TOOL BOX PASSENGER SEAT			\$236.00
759-006	DUAL DRIVER SEAT ARMRESTS AND INBOARD PASSENGER SEAT ARMREST	6		\$104.00



Prepared for:
 Marc Moreau
 BARRINGTON town of
 333 Calef Highway
 Barrington, NH 03825
 Phone: 603-948-5203

Prepared by:
 Charlie Grandll
 ATG MANCHESTER LLC
 222 FRONTAGE ROAD
 MANCHESTER, NH 03103
 Phone:

Data Code	Description	Weight Front	Weight Rear	Retail Price
711-004	LH AND RH INTEGRAL DOOR PANEL ARMRESTS			STD
758-121	BLACK LAREDO LEATHER DRIVER SEAT COVER			\$168.00
761-023	BLACK MORDURA CLOTH PASSENGER SEAT COVER			\$22.00
763-102	HIGH VISIBILITY ORANGE SEAT BELTS			\$13.00
532-002	ADJUSTABLE TILT AND TELESCOPING STEERING COLUMN	10		\$478.00
540-015	4-SPOKE 18 INCH (450MM) STEERING WHEEL			N/C
765-002	DRIVER AND PASSENGER INTERIOR SUN VISORS			STD
Instruments & Controls				
732-004	GRAY DRIVER INSTRUMENT PANEL			N/C
734-004	GRAY CENTER INSTRUMENT PANEL			N/C
870-001	BLACK GAUGE BEZELS			N/C
486-001	LOW AIR PRESSURE INDICATOR LIGHT AND AUDIBLE ALARM			STD
840-002	2 INCH PRIMARY AND SECONDARY AIR PRESSURE GAUGES			N/C
198-025	INTAKE MOUNTED AIR RESTRICTION INDICATOR WITHOUT GRADUATIONS			STD
721-006	CONSTANT 107 DECIBELS BACKUP ALARM		3	\$91.00
149-013	ELECTRONIC CRUISE CONTROL WITH SWITCHES IN LH SWITCH PANEL			N/C
156-007	KEY OPERATED IGNITION SWITCH AND INTEGRAL START POSITION; 4 POSITION OFF/RUN/START/ACCESSORY			STD
811-042	ICU3S, 132X48 DISPLAY WITH DIAGNOSTICS, 28 LED WARNING LAMPS AND DATA LINKED			N/C
160-039	(1) HEAVY DUTY ONBOARD DIAGNOSTICS INTERFACE CONNECTOR LOCATED BELOW LH DASH AND (1) SAE J1939 DIAGNOSTIC INTERFACE CONNECTOR LOCATED CENTER OF DASH			\$9.00
844-001	2 INCH ELECTRIC FUEL GAUGE			STD
148-003	PROGRAMMABLE RPM CONTROL - ELECTRONIC ENGINE			STD
856-001	ELECTRICAL ENGINE COOLANT TEMPERATURE GAUGE			STD
864-001	2 INCH TRANSMISSION OIL TEMPERATURE GAUGE			STD
830-017	ENGINE AND TRIP HOUR METERS INTEGRAL WITHIN DRIVER DISPLAY			STD
372-035	(1) DASH MOUNTED PTO SWITCH WITH INDICATOR LAMP	10		\$69.00



Prepared for:
 Marc Moreau
 BARRINGTON town of
 333 Calef Highway
 Barrington, NH 03825
 Phone: 603-948-5203

Prepared by:
 Charlie Grandll
 ATG MANCHESTER LLC
 222 FRONTAGE ROAD
 MANCHESTER, NH 03103
 Phone:

Data Code	Description	Weight Front	Weight Rear	Retail Price
852-002	ELECTRIC ENGINE OIL PRESSURE GAUGE			STD
679-001	OVERHEAD INSTRUMENT PANEL			STD
35M-001	SMARTPLEX HUB MODULE WITH OVERHEAD SWITCH MOUNTING, DRIVER SIDE ONLY (6 SWITCH SLOTS)	44		\$1,354.00
786-113	GENERIC TELEMATICS PREWIRE (CONSTANT BATTERY POWER/IGNITION/GROUND/J1939); RP1226 TYPE CONNECTOR AT PASSENGER SIDE OF DASH END			\$34.00
746-019	CUSTOMER FURNISHED DIN RADIO PACKAGE	5		\$195.00
747-001	DASH MOUNTED RADIO			N/C
750-002	(2) RADIO SPEAKERS IN CAB			N/C
* 748-006	POWER AND GROUND WIRING PROVISION OVERHEAD			\$9.00
749-001	ROOF/OVERHEAD CONSOLE CB RADIO PROVISION			\$38.00
* 752-017	MULTI-BAND AM/FM/WB/CB LH MIRROR MOUNTED ANTENNA SYSTEM			\$293.00
810-027	ELECTRONIC MPH SPEEDOMETER WITH SECONDARY KPH SCALE, WITHOUT ODOMETER			STD
817-008	STANDARD VEHICLE SPEED SENSOR WITH ADDITIONAL SIGNAL FOR CUSTOMER USE LOCATED BETWEEN DRIVER AND PASSENGER SEATS			\$10.00
812-001	ELECTRONIC 3000 RPM TACHOMETER			STD
162-002	IGNITION SWITCH CONTROLLED ENGINE STOP			STD
329-007	ONE ON/OFF ROCKER SWITCH IN THE DASH WITH INDICATOR LIGHT WIRED TO JUNCTION BLOCK ON FRAME WITH MARKER LIGHT CIRCUIT, LABEL OPT			\$93.00
81Y-001	PRE-TRIP LAMP INSPECTION, ALL OUTPUTS FLASH, WITH SMART SWITCH			\$12.00
44R-005	5 ON/OFF LATCHING SMARTPLEX SWITCHES			\$60.00
44U-001	1 ON/OFF/ON MOMENTARY SMARTPLEX SWITCH			\$13.00
482-001	BW TRACTOR PROTECTION VALVE			N/C
883-001	TRAILER HAND CONTROL BRAKE VALVE			N/C
836-015	DIGITAL VOLTAGE DISPLAY INTEGRAL WITH DRIVER DISPLAY			STD
660-025	SINGLE ELECTRIC WINDSHIELD WIPER MOTOR WITH DELAY PROGRAMMED TO SLOWEST SPEED WITH PARK BRAKE SET			\$19.00



Prepared for:
 Marc Moreau
 BARRINGTON town of
 333 Calef Highway
 Barrington, NH 03825
 Phone: 603-948-5203

Prepared by:
 Charlie Grandll
 ATG MANCHESTER LLC
 222 FRONTAGE ROAD
 MANCHESTER, NH 03103
 Phone:

Data Code	Description	Weight Front	Weight Rear	Retail Price
304-038	MARKER LIGHT SWITCH INTEGRAL WITH HEADLIGHT SWITCH AND SINGLE CONNECTOR AND SWITCH FOR CUSTOMER FURNISHED SNOW PLOW LIGHTS, LOW BEAMS OFF WITH HIGH BEAMS			\$178.00
882-021	TWO VALVE PARKING BRAKE SYSTEM WITH DASH VALVE CONTROL AUTONEUTRAL AND WARNING INDICATOR			\$13.00
299-013	SELF CANCELING TURN SIGNAL SWITCH WITH DIMMER, WASHER/WIPER AND HAZARD IN HANDLE			N/C
298-039	INTEGRAL ELECTRONIC TURN SIGNAL FLASHER WITH HAZARD LAMPS OVERRIDING STOP LAMPS			STD

Design

* 065-000	PAINT: ONE SOLID COLOR			\$1,043.00
-----------	------------------------	--	--	------------

Color

* 980-MSV	CAB COLOR A: B8713EY GARNET MET ELITE EY	MED		N/C
986-020	BLACK, HIGH SOLIDS POLYURETHANE CHASSIS PAINT			STD
962-972	POWDER WHITE (N0006EA) FRONT WHEELS/RIMS (PKWHT21, TKWHT21, W, TW)			STD
966-972	POWDER WHITE (N0006EA) REAR WHEELS/RIMS (PKWHT21, TKWHT21, W, TW)			STD
976-995	SUNVISOR PAINTED SAME AS CAB COLOR A			N/C
963-003	STANDARD E COAT/UNDERCOATING			STD

Certification / Compliance

996-001	U.S. FMVSS CERTIFICATION, EXCEPT SALES CABS AND GLIDER KITS			STD
---------	---	--	--	-----

Raw Performance Data

AE8-99D	CALCULATED EFFECTIVE BACK OF CAB TO REAR SUSPENSION C/L (CA) : 93.85 in
---------	---

Sales Programs

NO SALES PROGRAMS HAVE BEEN SELECTED

TOTAL VEHICLE SUMMARY

Adjusted List Price

Adjusted List Price ** \$155,602.00



Prepared for:
 Marc Moreau
 BARRINGTON town of
 333 Calef Highway
 Barrington, NH 03825
 Phone: 603-948-5203

Prepared by:
 Charlie Grandll
 ATG MANCHESTER LLC
 222 FRONTAGE ROAD
 MANCHESTER, NH 03103
 Phone:

Weight Summary

	Weight Front	Weight Rear	Total Weight
Factory Weight ⁺	8120 lbs	4833 lbs	12953 lbs
Total Weight ⁺	8120 lbs	4833 lbs	12953 lbs

ITEMS NOT INCLUDED IN ADJUSTED LIST PRICE

Other Factory Charges

PNZ-002	CARB22 BASE WARRANTY DD8 DS/B6.7/ L9 >=330	\$1,670.00
PMV-021	GHG21 ENHANCEMENT PRICE	\$510.00
RAG-020	CUMMINS TARIFF CHARGE - \$205	\$205.00
RFY-022	FRONT TIRE SURCHARGE	\$50.00
RFU-022	REAR TIRE SURCHARGE	\$100.00
RFZ-023	MY23 PRODUCTION COST SURCHARGE	\$2,900.00
P73-2FT	STANDARD DESTINATION CHARGE	\$2,700.00

(+) Weights shown are estimates only.

If weight is critical, contact Customer Application Engineering.

(**) Prices shown do not include taxes, fees, etc... "Net Equipment Selling Price" is located on the Quotation Details Proposal Report.

(***) All cost increases for major components (Engines, Transmissions, Axles, Front and Rear Tires) and government mandated requirements, tariffs, and raw material surcharges will be passed through and added to factory invoices.



Prepared for:
 Marc Moreau
 BARRINGTON town of
 333 Calef Highway
 Barrington, NH 03825
 Phone: 603-948-5203

Prepared by:
 Charlie Grandll
 ATG MANCHESTER LLC
 222 FRONTAGE ROAD
 MANCHESTER, NH 03103
 Phone:

DIMENSIONS

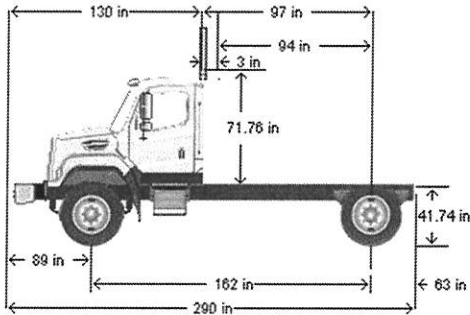

VEHICLE SPECIFICATIONS SUMMARY - DIMENSIONS

Wheelbase (545)	4125MM (162 INCH) WHEELBASE
Rear Frame Overhang (552)	1600MM (63 INCH) REAR FRAME OVERHANG
Fifth Wheel (578)	NO FIFTH WHEEL
Mounting Location (577).....	NO FIFTH WHEEL LOCATION
Maximum Forward Position (in).....	0
Maximum Rearward Position (in)	0
Amount of Slide Travel (in).....	0
Slide Increment (in).....	0
Desired Slide Position (in).....	0.0
Cab Size (829).....	108 INCH BBC FLAT ROOF ALUMINUM CONVENTIONAL CAB
Sleeper (682).....	NO SLEEPER BOX/SLEEPER CAB
Exhaust System (016).....	RH OUTBOARD UNDER STEP MOUNTED HORIZONTAL AFTERTREATMENT SYSTEM ASSEMBLY WITH RH B-PILLAR MOUNTED VERTICAL TAILPIPE

TABLE SUMMARY - DIMENSIONS

Prepared for:
 Marc Moreau
 BARRINGTON town of
 333 Calef Highway
 Barrington, NH 03825
 Phone: 603-948-5203

Prepared by:
 Charlie Grandll
 ATG MANCHESTER LLC
 222 FRONTAGE ROAD
 MANCHESTER, NH 03103
 Phone:

Dimensions	Inches
Bumper to Back of Cab (BBC)	130.1
Bumper to Centerline of Front Axle (BA)	88.6
Min. Cab to Body Clearance (CB)	3.0
Back of Cab to Centerline of Rear Axle(s) (CA)	96.9
Effective Back of Cab to Centerline of Rear Axle(s) (Effective CA)	93.9
Back of Cab Protrusions (Exhaust/Intake) (CP)	2.0
Back of Cab Protrusions (Side Extenders/Trim Tab) (CP)	0.0
Back of Cab Protrusions (CNG Tank)	0.0
Back of Cab Clearance (CL)	3.0
Back of Cab to End of Frame	159.8
Cab Height (CH)	71.8
Wheelbase (WB)	162.4
Frame Overhang (OH)	63.0
Overall Frame Length	290.5
Overall Length (OAL)	289.9
Rear Axle Spacing	0.0
Unladen Frame Height at Centerline of Rear Axle	41.7

Performance calculations are estimates only. If performance calculations are critical, please contact Customer Application Engineering.



Prepared for:
 Marc Moreau
 BARRINGTON town of
 333 Calef Highway
 Barrington, NH 03825
 Phone: 603-948-5203

Prepared by:
 Charlie Grandll
 ATG MANCHESTER LLC
 222 FRONTAGE ROAD
 MANCHESTER, NH 03103
 Phone:

TURNING RADIUS

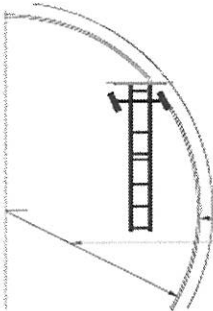

Turning radius graphic and data provided strictly for comparisons between model configurations. Weather, road surfaces, and tire treads affect the results. It is strongly suggested that actual vehicles be measured before constructing any roads/driveways using this information. For specific figures regarding your configuration, please contact your CAE representative.

	Dimensions	Tolerance
Wall to Wall Diameter (ft)	67.0	+/- 3.0
Curb to Curb Diameter (ft)	58.6	+/- 3.0
Turning Radius (ft)	28.8	+/- 1.5

VEHICLE SPECIFICATIONS SUMMARY - TURNING RADIUS

Cab Size (829)	108 INCH BBC FLAT ROOF ALUMINUM CONVENTIONAL CAB
Wheelbase (545)	4125MM (162 INCH) WHEELBASE
Front Tires (093)	MICHELIN XZE2 11R22.5 16 PLY RADIAL FRONT TIRES
Width (in)	11.3
Front Axle (400)	MFS-20-133A 20,000# FL1 71.0 INCH KPI/3.74 INCH DROP SINGLE FRONT AXLE
Kingpin Intersection (in)	71
Bumper (556)	OMIT FRONT BUMPER, CUSTOMER INSTALLED SPECIAL BUMPER, DOES NOT COMPLY WITH FMCSR 393.203
Width (in)	96
Bumper Miter to Front Axle (in)	93.262
Primary Steering Location (003)	LH PRIMARY STEERING LOCATION
Steering Gear (536)	TRW THP-60 POWER STEERING WITH RCH45 AUXILIARY GEAR
Dual Steering Gear	RCH45
Ram	NONE
Rear Axle (420)	RS-30-185 30,000# U-SERIES SINGLE REAR AXLE
Axle Spacing (624)	NO AXLE SPACING

Performance calculations are estimates only. If performance calculations are critical, please contact Customer Application Engineering.

